

Operators Manual for Capture Jet® Hoods with Water Wash Technology

Manual provides
Operation, Maintenance and Service Instructions

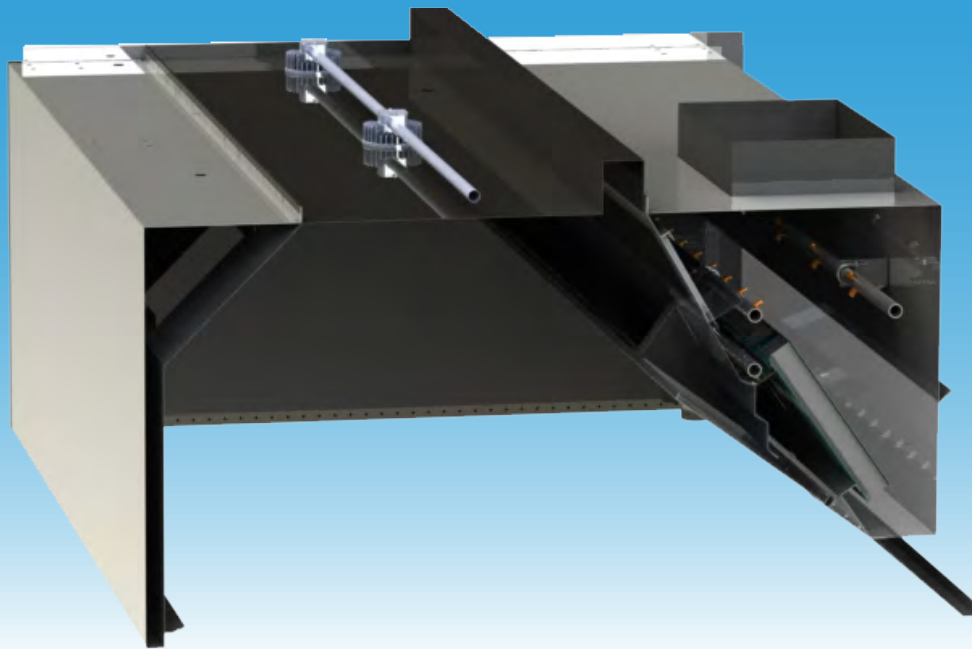

Capture Jet® Hoods with Water Wash Technology
KVE-WW, KVC-WW

Halton

General Description

Halton's Water Wash technology provides solutions for a variety of commercial food service ventilation applications over virtually any cooking process. Based on Halton's patented highly efficient Capture Jet® solution and advanced mechanical KSA filter technology, the Water Wash feature keeps the plenum virtually grease free. Halton's Automatic Water Wash features allow for continuous operation without extended shut down for cleaning. The hot water wash down is especially suited to facilities with cooking operation producing substantial volumes of grease and requires reduced maintenance. The Water Wash system includes three full length wash manifolds equipped with brass spray nozzles. These manifolds wash the exhaust plenum area and the KSA grease filters. When the wash cycle is initiated the exhaust fan shall shut off. The Water Wash system is built into the hood with complete controls and safety features. The hood is complete with a control panel indicating the total hours of operation, safety alarms, security on, and exhaust fan failure.

The control panel is connected to the electrical control box of the fan via a relay which detects any exhaust fan failures.

To achieve the optimum performance from your hood system (s) please use the following guidelines provided within the pages of this Installation, Operation and Maintenance Manual.

In addition to this information technical support is available from the Halton Factory during regular office hours, 7 A.M. to 5 P.M. Central Time, to provide support for products, applications, installation, commissioning or for any aspect that you may have. Our local sales representatives can also provide support.

Recommendation

Upon receipt of the Halton hood (s), inspect unit (s) immediately for any shipping damage and notify carrier immediately if damage is found. Halton will not accept responsibility for any shipping damage. All systems are thoroughly inspected before leaving our factories; however Halton will assist in filing a claim if needed.

General installation

It is the responsibility of the installing contractor to see that the system installation is completed in accordance with the project plans and specifications and that it meets all specific requirements of local code officials. The local authority having jurisdiction could over rule some of the installation details written in this manual. The installation shall be in accordance with NFPA-96. All electrical systems shall be installed following local and national codes.

The owner and/or operator should be instructed in the proper operation, care and maintenance of the system.

If questions or complications should arise during the installation of the Halton hood (s) that cannot be solved using the instructions provided please contact the Halton office at 1-800-442-5866, or (1-800-4-HALTON).

Note: There are no instructions contained within this manual for installation or maintenance of fan packages.

****See appropriate manufacturers manual for detailed instructions.**

Exhaust Airflows

Please see submittal drawings or contact the manufacturer for each hood's exhaust air flow rates. Halton's applications department determines the optimum exhaust rate for effective capture & containment of cooking effluent. These exhaust airflows are included in the job submittal drawings for each hood and are customized for the specific kitchen appliance arrangement and environment.

Installation Instructions

1. Inspect the crating carefully. If there are signs of damage, call the freight carrier before uncrating the units. Carefully uncrate the units. Check all local codes prior to installation; special requirements may be necessary depending on local building material construction.

**** Important note **** Do not leave unit (s) exposed to extreme temperatures for an extended period of time, this may cause the protective PVC coating around the unit (s) to become very difficult to remove.

2. Position the hood near the actual installation site. In case of multiple hoods, check the engineered set of drawings for locations. Pay close attention to collar sizes and fire protection layouts, matching the hood systems to the correct location shown on the drawings provided.

****Check item numbers on crates / hoods vs. drawing item numbers.**

3. Once the hood is carefully removed from the shipping crate and set in position, the unit is now ready for installation. If Halton Company has supplied a backsplash assembly, then the splash assembly should be installed first, for installation procedures see pg. 6.
4. Hang the hood using ½" threaded rods by attaching the rods to the hood through the hanger brackets that are welded to the top of the hood. Use of turnbuckles with the threaded rod sections will make final adjustment easier. Standard hanging height for canopy hoods ranges from 78" min. to 84" max. from the finished floor to the lower edge of the front of the hood (per local codes having jurisdiction).
****Noted in installation details illustration- see pg. 7.**

Note:

Allow 100lbs (45kg) per linear foot hanging weight.

Do not lift exhaust hoods from their end panels. Lift from four corners

All exhaust hoods and control panels are fitted together and factory tested prior to shipping for alignment and operation.

5. Duct connections must meet NFPA 96 requirements and applicable local codes. Size of connection is indicated on exhaust hood drawing. Connection is to be made after exhaust hood is hung.
6. Electrical circuits should be connected according to the job specific wiring diagram shown on the submittal drawings. Water Wash hoods have additional wiring requirements to connect the control panel to the hoods, as well as connections between multiple hoods operated from the same control panel. A typical field wiring diagram showing these connections is shown on pg. 30. The following electrical service requirements are field installed:

A 120 volt, 15 amp uninterrupted supply to the control panel.

A separate 120 volt, 15 amp supply to the light fixture junction box(es) on top of each hood.

A 120 volt circuit from the control panel to the exhaust fan starter coil or relay.

A 120 volt circuit from the control panel to the make up air fan starter coil or relay.

There is a 2 wire circuit to the fire suppression micro switch for a dry contact closure to let the control panel know of a fire condition under the hood.

There may be additional wiring circuits for fire alarm notification to a building BMS. This is optional.

Note: The selector switch on the control panel controls the exhaust fan operation.

Please see job specific wiring connection information in the job submittal drawings and an additional wiring diagram is included in the electrical control box shipped with the job. Additional copies may be obtained from the factory if this wiring diagram is missing or lost. Please be prepared to provide the job order number (found on the sales invoice), job name and address or submittal drawing series number when contacting the factory for this or other job specific documents.

7. Plumbing service requirements:

1. Hot water supply to the control panel must be sized to accept appropriate volume of water measured in U.S. gallons per minute at 40 psig/min. at a constant flow pressure of 25 psig at the hot water nozzles in the hood. Supply the recommended hot water temperature of 120°F (50°C) to 140°F (60°C). Calculate water requirements by using the longest water wash hood served by the control panel and multiplying the length of this hood, in feet, by 1.2. The result will be the figure used for gallons per minute. Example: The longest hood connected to the control panel is 168" long. $168/12 = 14$ feet, $14 \times 1.2 = 16.8$ gallons per minute.

2. Supply and connect 1" ips for hot water to control panel, provide and connect 1" lines to ventilator sections. Supply and connect drains as specified from ventilator section(s) to floor drain as required by local codes. Waste drain is 2" pipe. Do not use 90° elbows in drain line. If 90° bend is required use two 45° fittings. If traps are required in drain line install it in the vertical section of the line. Supply and install grease traps as required by local codes, sized to handle maximum volume as calculated above. Supply and install back flow preventers, anti-syphon valves or vacuum breakers as required by local codes. Di-electric connections, where required by code on water supply feed to panel, are to be supplied by mechanical trade. Internal piping in control panel is brass. Hot water lines should be thoroughly flushed prior to connecting lines to control panel. Remove one of the spray nozzles farthest from water intake to flush lines, replace nozzle when flushing is completed. Inlet and drain line attachment points at the hood are illustrated on pg. 5.

8. Halton hoods come standard with high output, long lasting LED light fixtures. Optionally incandescent or recessed fluorescent fixtures may be ordered. Please note only install 100 watt maximum light bulbs in incandescent light fixtures. Fluorescent bulbs should be type T8, 36" or 48" long in fluorescent fixtures. **Note: Halton does not provide bulbs for incandescent or fluorescent lights.

9. For multiple hoods end to end, or back to back see pg. 9 for Installation of Splice Strips and U-Channels.

10. If Closure Panels are supplied by Halton see pgs. 10 - 12 for details on the installation.

11. Protect the hood from damage under normal job site conditions, until all work is complete and system is ready to be put into operation.



Water Inlet point on back of hood.

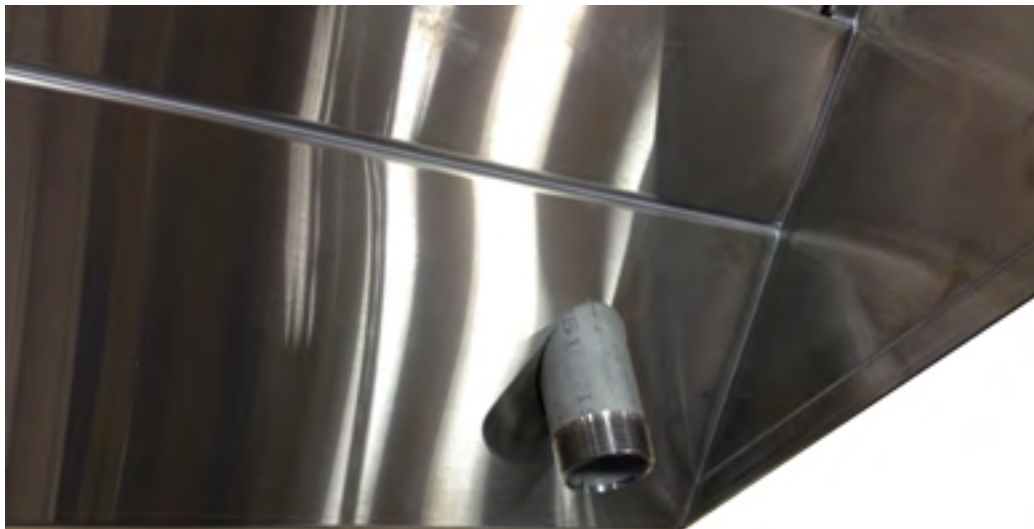

Water Drain point on hood.

Backsplash Installation

1" Insulated Backsplash Assembly

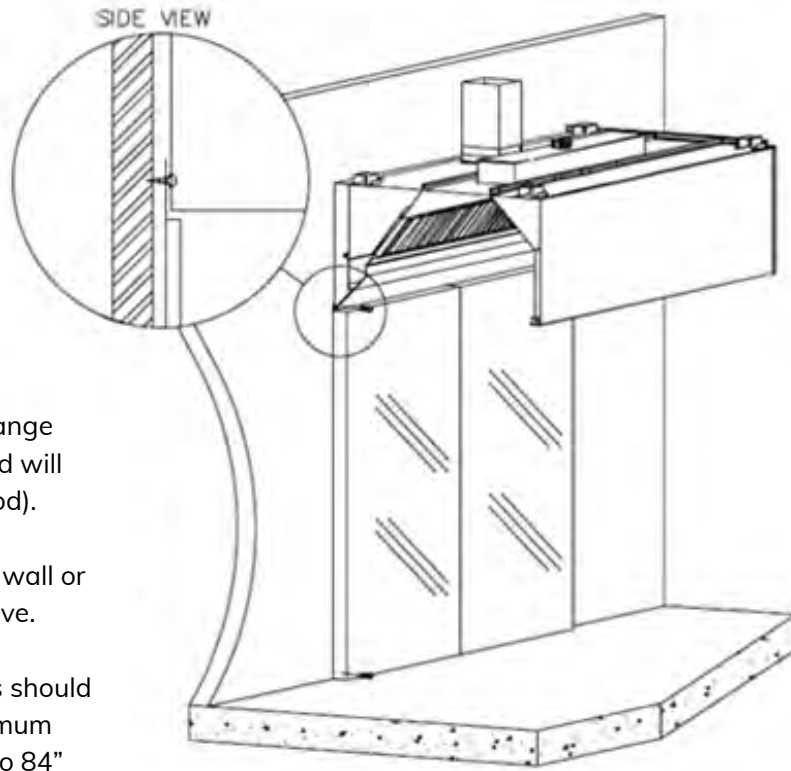

Screw through top flange into wall. (Screw head will not interfere with hood).

Screw backsplash to wall or attached with adhesive.

Halton canopy hoods should be installed 78" minimum above finished floor to 84" maximum above finished floor.

Flat Sheet Backsplash Assembly

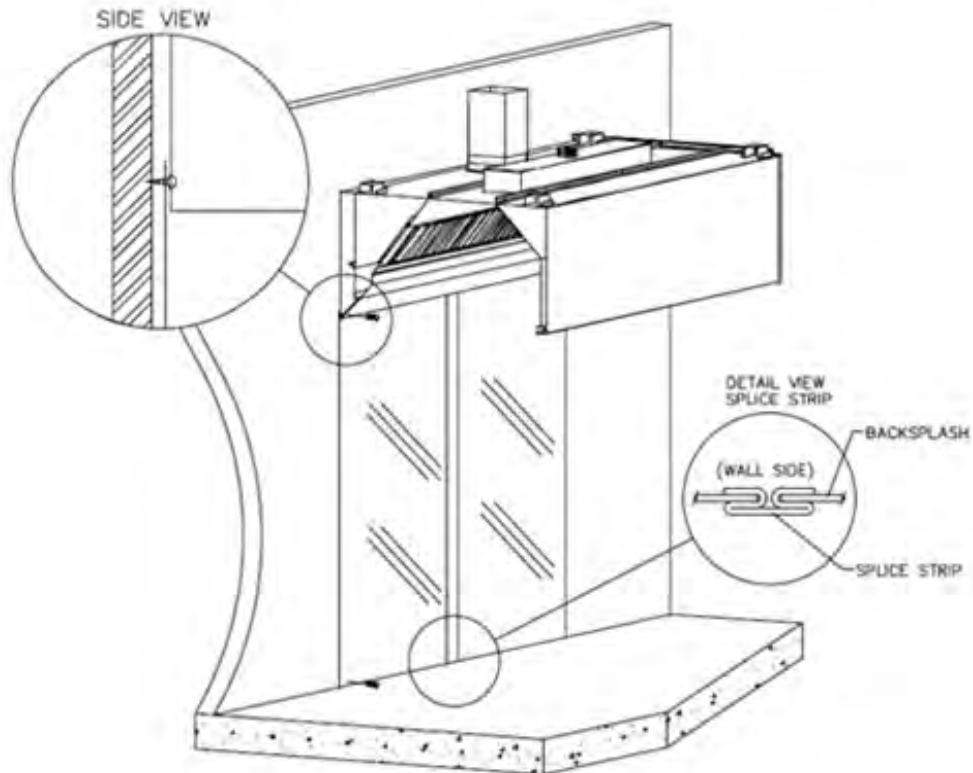

Hood Installation Details

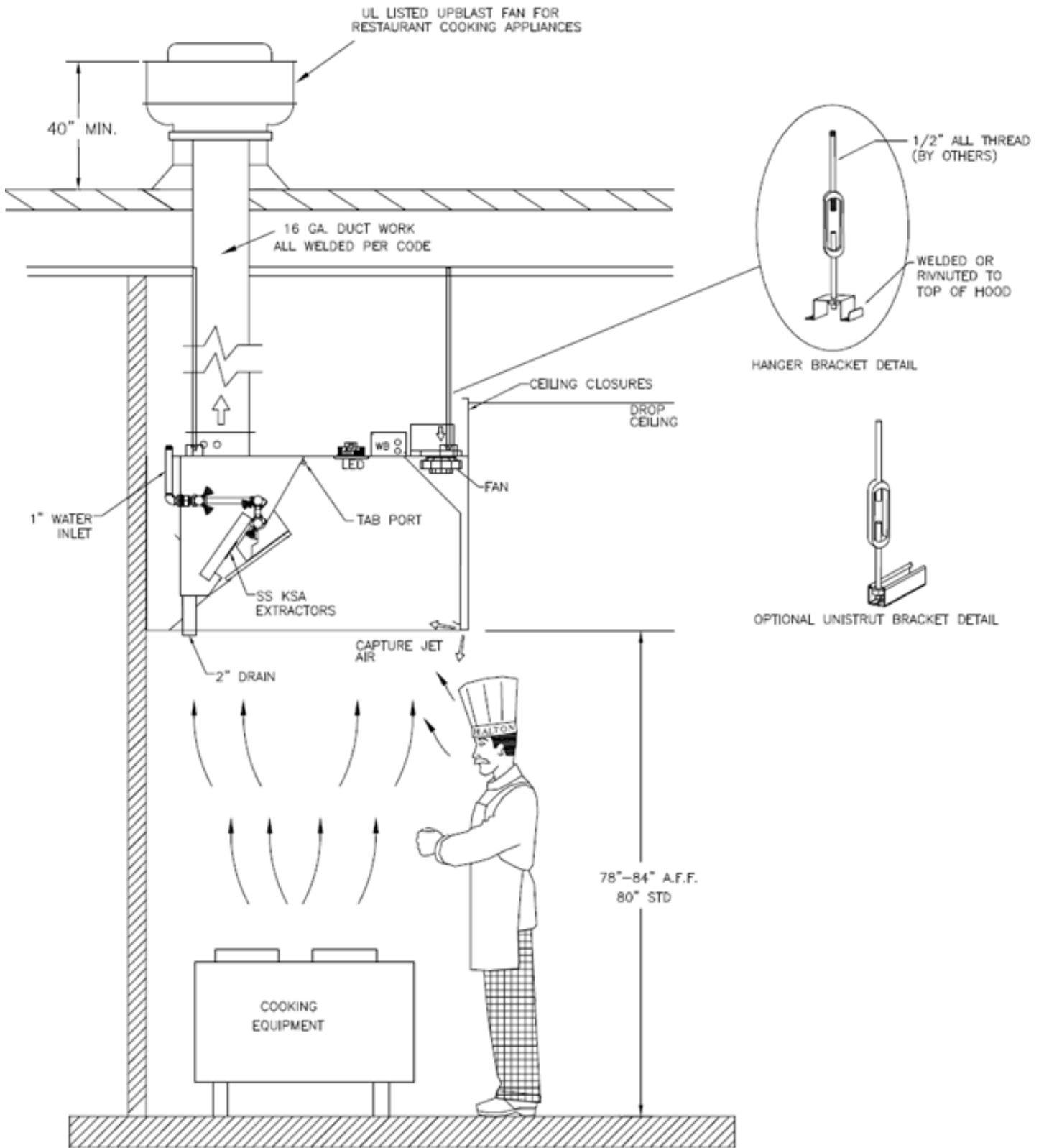

Exhaust Duct Connection Details

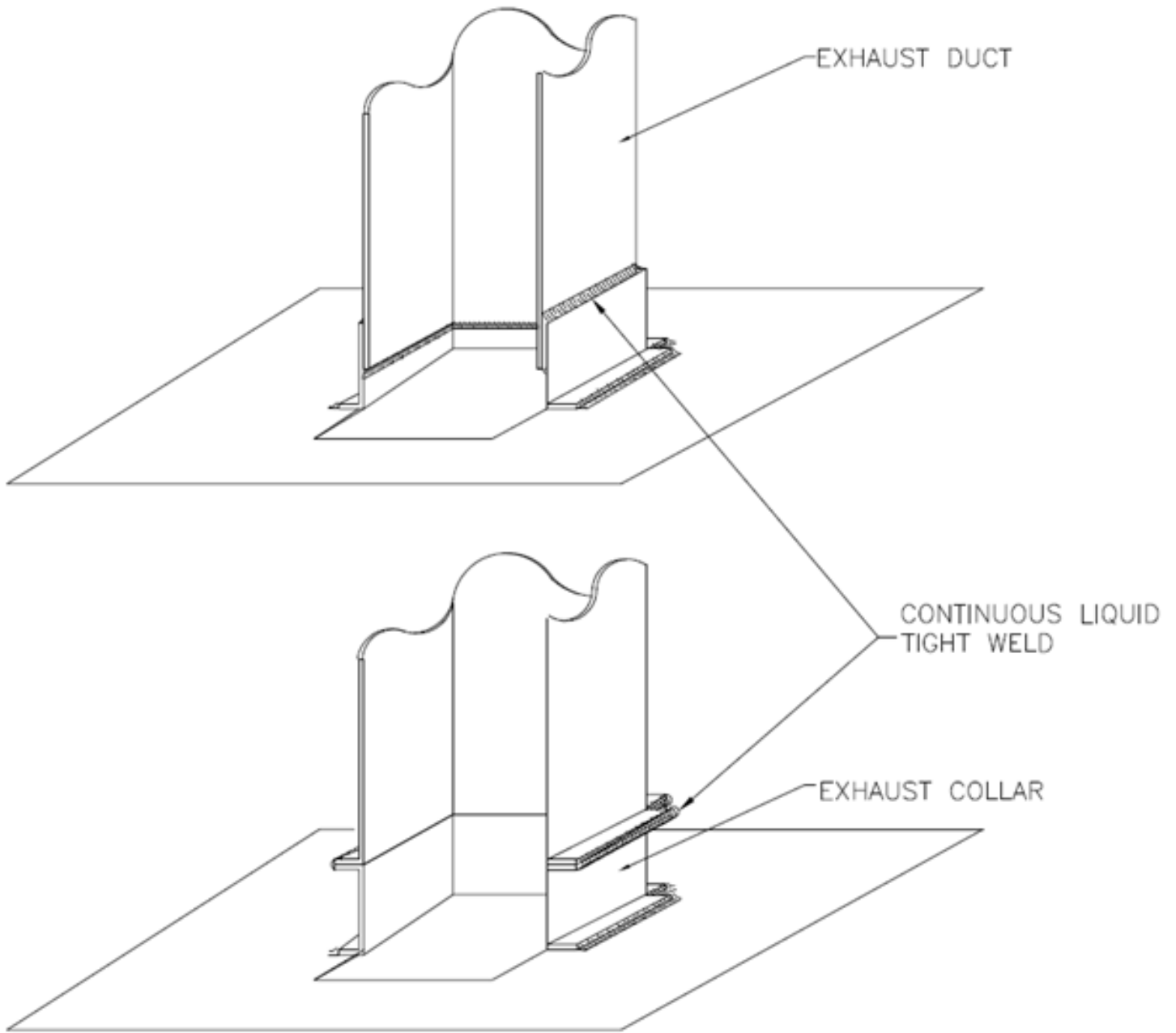

Splice Strip/u-channel Assemblies

Hoods end to end

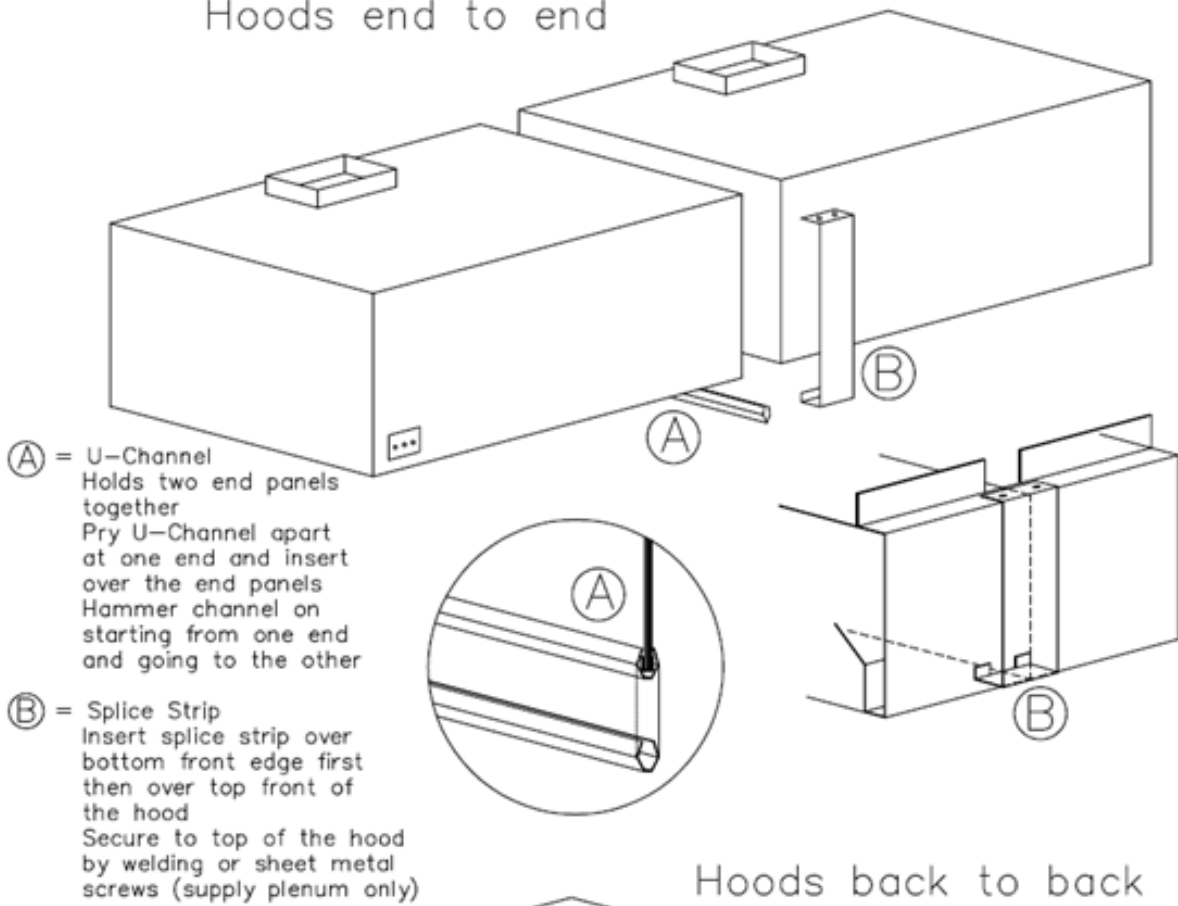

Hoods back to back

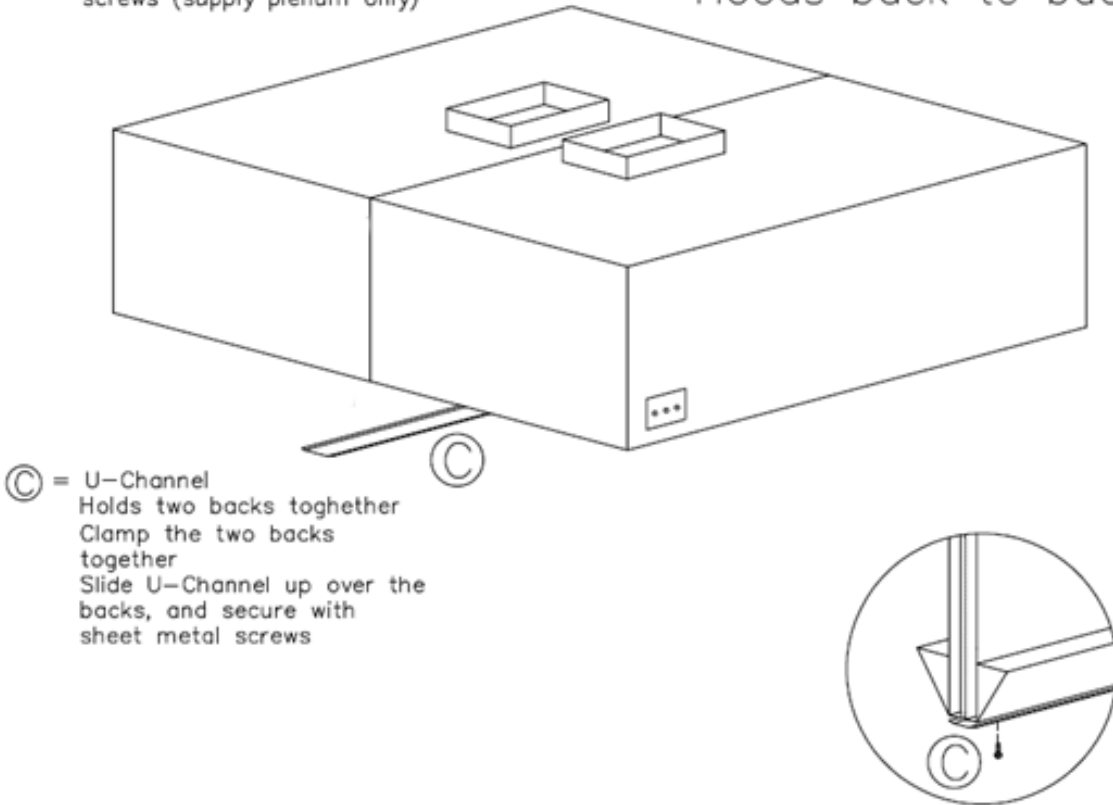

Closure Panel Assembly

Single Hood

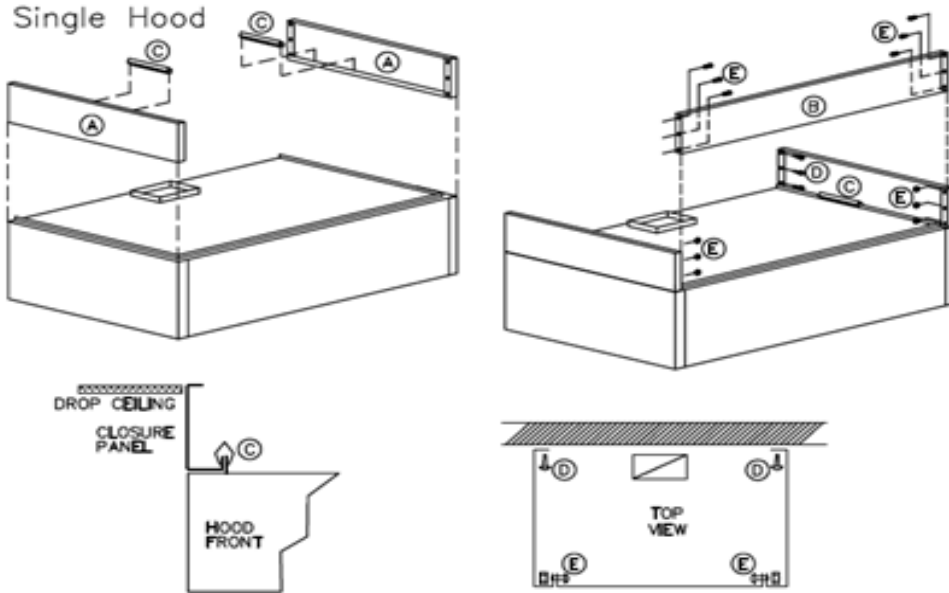

1. Panels "A" are placed on the top of the hood on the outside perimeter of the hood at each end of the hood group.
2. Align the clips "C" over vertical flanges and hammer clips down over flanges.
3. Attach panels "A" to rear wall with hardware "D".
4. Attach panel(s) "B" to panels "A" with hardware "E" .

End to End Hoods

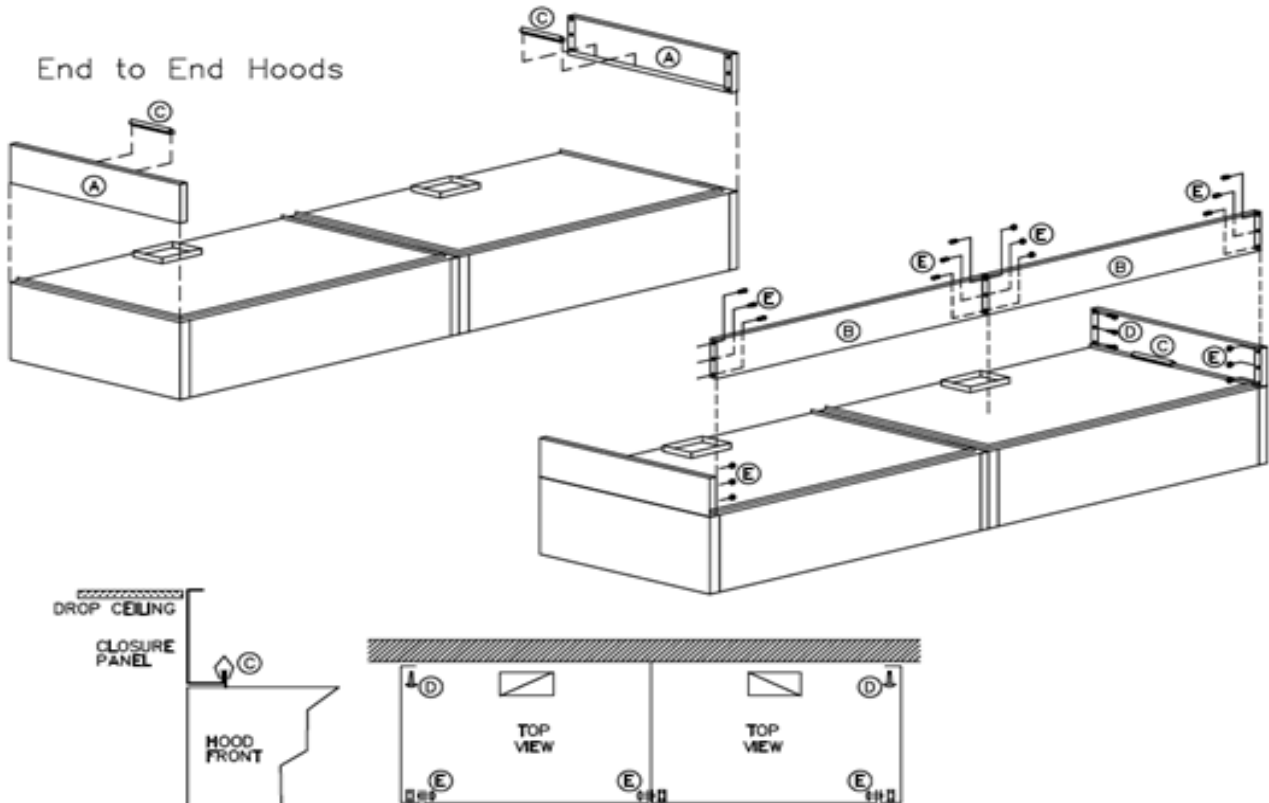

Back to Back Hoods

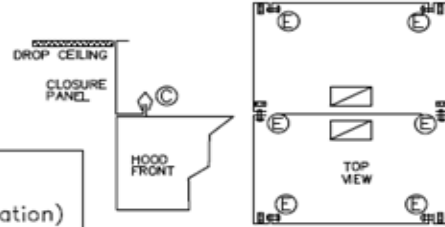
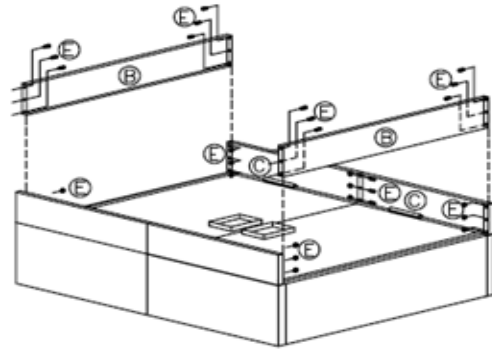
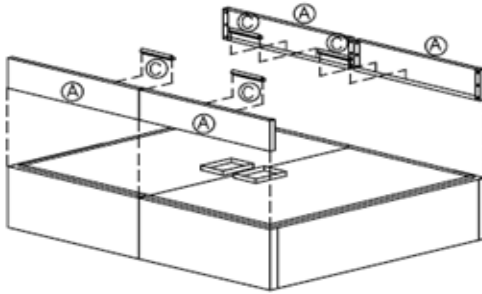

- (C) — Closure Clips (By Halton)
- (D) — Wall Attachment Hardware (Not Used in this Configuration)
- (E) — Panel Connection Hardware (By Others)

1. Panels "A" are placed on the top of the hood on the outside perimeter of the hood at each end of the hood group.
2. Align the clips "C" over vertical flanges and hammer clips down over flanges.
3. Attach panels front "A" panels to rear "A" panels with hardware "E".
4. Attach panels "B" to panels "A" with hardware "E".

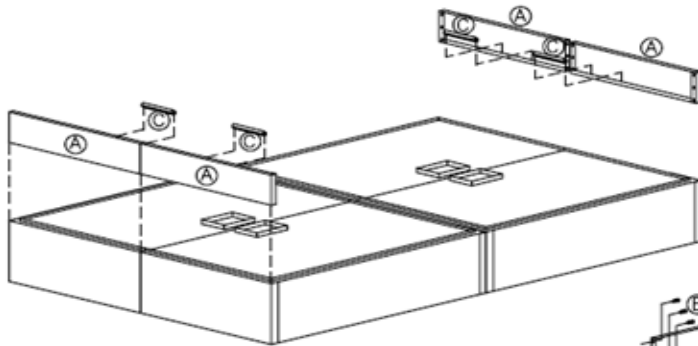

End to End and Back to Back Hoods

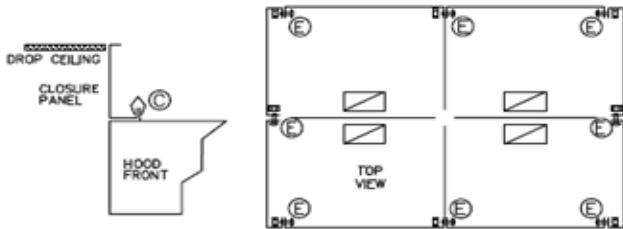
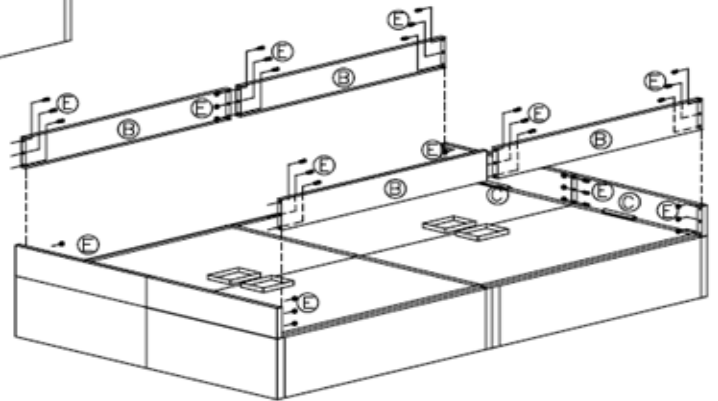

Hoods with KDS Risers

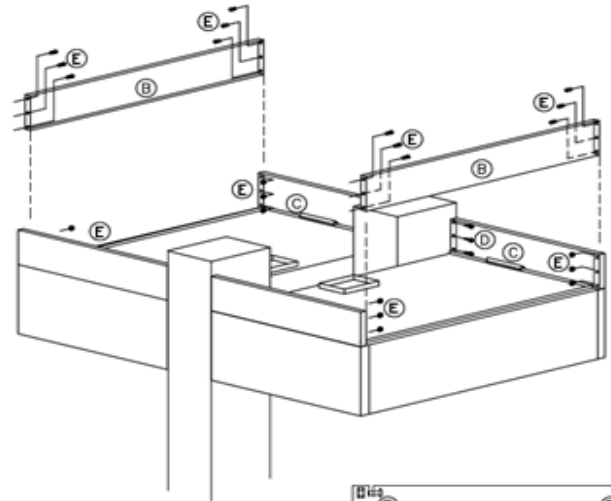
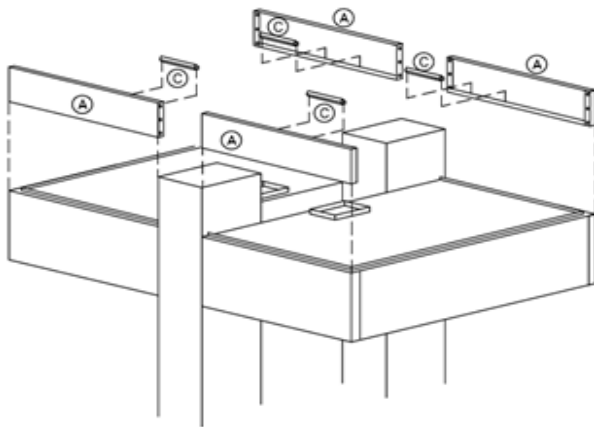

1. Panels "A" are placed on the top of the hood on the outside perimeter of the hood at each end of the hood group.
2. Align the clips "C" over vertical flanges and hammer clips down over flanges.
3. Attach panels front "A" panels to KDS riser columns with hardware "D".
4. Attach panels "B" to panels "A" with hardware "E".

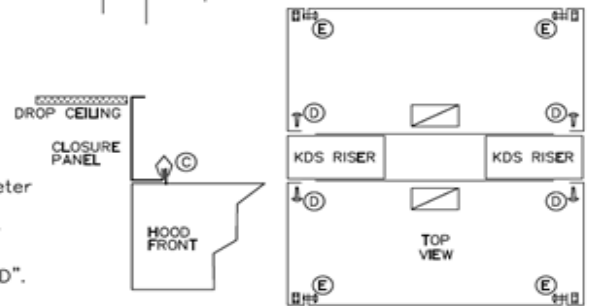

To Start the Hood

Halton hoods are typically operated from pushbutton switches found at the bottom of the front edge of the hood. Custom hood configurations may have the switches located somewhere else, such as a remote switch or a software switch on a touch screen control panel. A hood or hoods operated by the Halton M.A.R.V.E.L. Demand Control Ventilation (DCV) system will not have a control button for the fan. The M.A.R.V.E.L. system will start the fan automatically. Press the "Fan" button to start the hood(s) exhaust fan. Press the "Light" button to turn on the hood lights and also start the hood Capture Jet fan, which is on the same electrical circuit as the hood lights. Multiple hoods in a hood group ducted to a single exhaust fan will usually all turn on from a single switch panel.



STANDARD HOOD SWITCH PANEL



REMOTE SWITCH PANEL

Standard Capture Jet Hood Wiring

TYPICAL WIRING OF CAPTURE-JET FAN W/HALTON SUPPLIED SWITCH PANEL

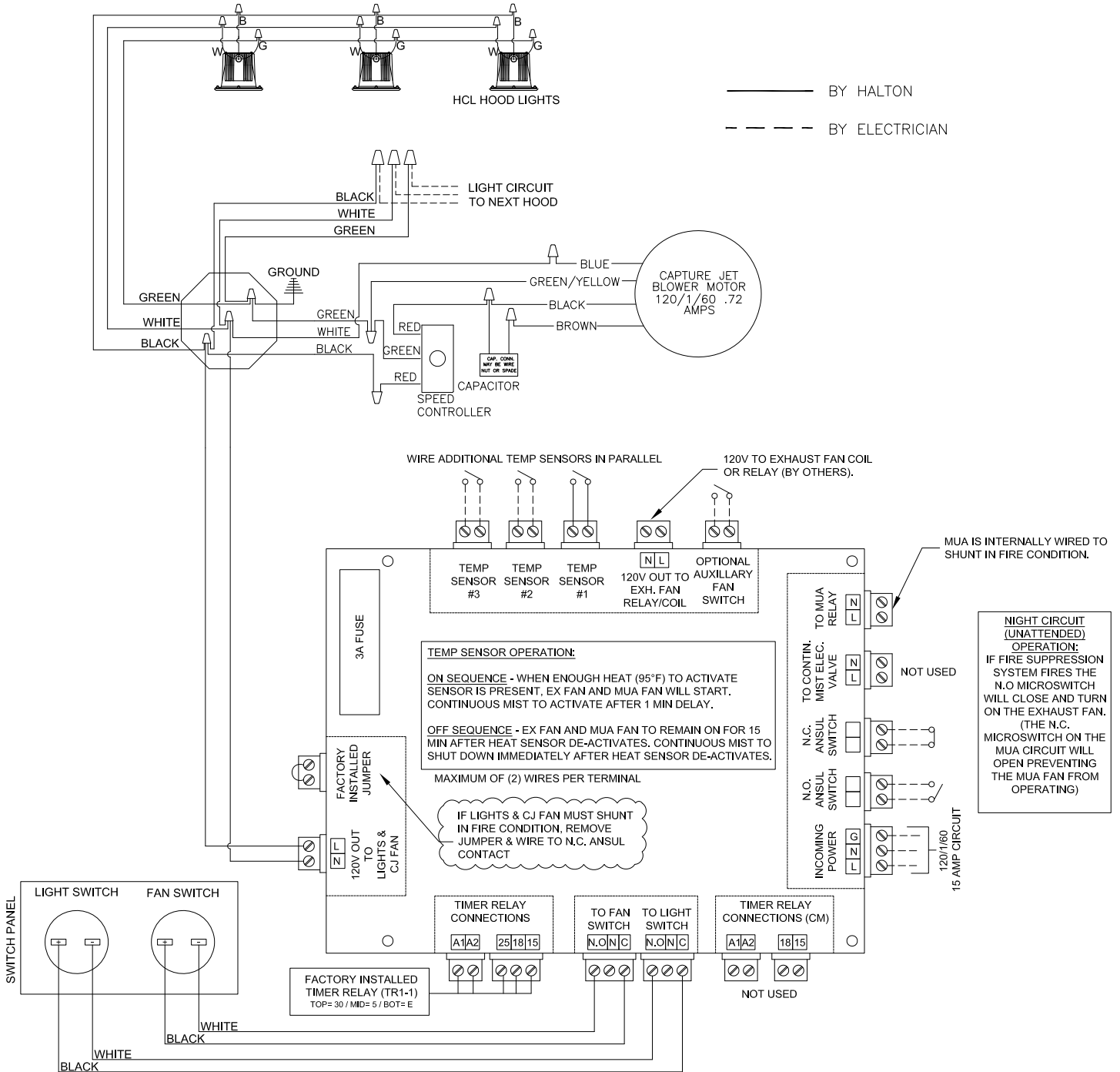

Operation Of System

1. After installation is complete it will be necessary to check and balance the airflows through each hood. The static pressure for each hood is listed in the hood information table on the job specific submittal drawings. The specific exhaust static pressure for each hood should be referenced for the airflow balance for that hood. The exhaust air being drawn through the grease filters creates a negative static pressure behind the filters in the exhaust plenum. This negative static pressure can be measured and has a direct relationship to the total exhaust airflow measured in CFM (Cubic Feet per Minute). Halton Capture Jet hoods are calibrated based on the model of hood and the number of grease filters the hood has. A static pressure curve is provided with each hood which allows the air balancer to easily set up the exhaust fan to draw the correct exhaust CFM through the hood based on measuring the static pressure of the exhaust plenum. On the Capture Jet® line of hoods, Halton supplies T.A.B. (Testing And Balancing) ports for measuring the negative static pressure drop through the filters and also the positive Capture Jet® plenum pressure. These ports are located on the inside of the capture portion of the canopy on the exhaust and Capture Jet® plenums. The T.A.B. port for measuring exhaust static pressure is on the exhaust plenum side of the hood, near the top inside panel and is found near one of the corners above the grease filters. The T.A.B. port for measuring the Capture Jet® static pressure is found in the inner front of the hood, near the top inside panel and near one of the corners of the inner face. There is a black plastic cap on each of the brass T.A.B. port fittings to keep them clean. The cap should be removed for taking the static pressure measurements and then replaced when the measurements are completed. The exhaust static pressure is measured using the negative connection on the manometer, leaving the positive port of the manometer open to atmosphere. The Capture Jet® static pressure is measured using the positive connection on the manometer, leaving the negative port of the manometer open to atmosphere. Adjustment to the static pressure of the exhaust plenum is made by adjusting the speed of the exhaust fan. Adjustment to the Capture Jet fan is made inside the inner front of the hood at the Capture Jet speed controller. See procedure below if Capture Jet fan adjustment is necessary.

****It is very important that the fan for the Capture Jet® air be balanced according to specifications.** See the job specific information for required airflows. The Capture Jet fan is adjusted at the factory for proper airflow. Check the static pressure of the Capture Jet plenum and adjust the Capture Jet fan speed only if the pressure reading is different than the T.A.B. port pressure specified on the job specific submittal drawings (measured reading outside of plus or minus 0.05" w.c.). Adjustments to the Capture Jet® fan can be made with the speed controller supplied with the fan. This speed controller will be mounted inside the Capture Jet plenum; the adjustment control knob can be accessed by removing the chrome button cover in the center of the Capture Jet fan access cover. The speed controller is adjusted using a small flathead screwdriver, turning the control clockwise to decrease the speed of the Capture Jet fan, and turning the control counterclockwise to increase the speed. Very small movements of the control will result in appreciable static pressure changes to the Capture Jet plenum. Monitor the manometer connected to the T.A.B. port of the Capture Jet plenum as adjustments are made. After each adjustment allow the pressure to stabilize before adjusting further.

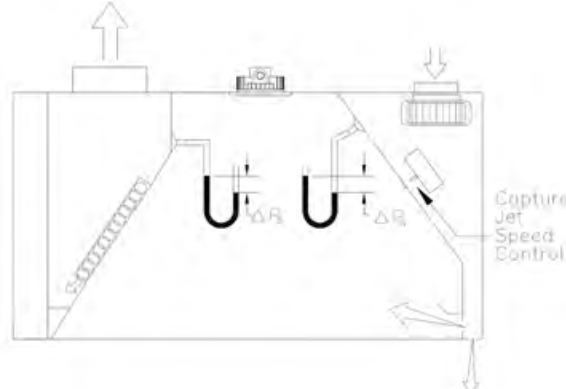

The Capture Jet® and exhaust air flows are easily and accurately determined by measuring the pressure difference from the T.A.B. (Testing and Balancing) ports mounted in each plenum. The corresponding air flows can be read from the diagram provided.

To properly measure T.A.B. port readings use a magnehelic gauge or digital manometer and for exhaust plenum reading hookup hose from negative connection on instrument to T.A.B. Port on exhaust plenum. Leave positive connection on instrument open to atmosphere.

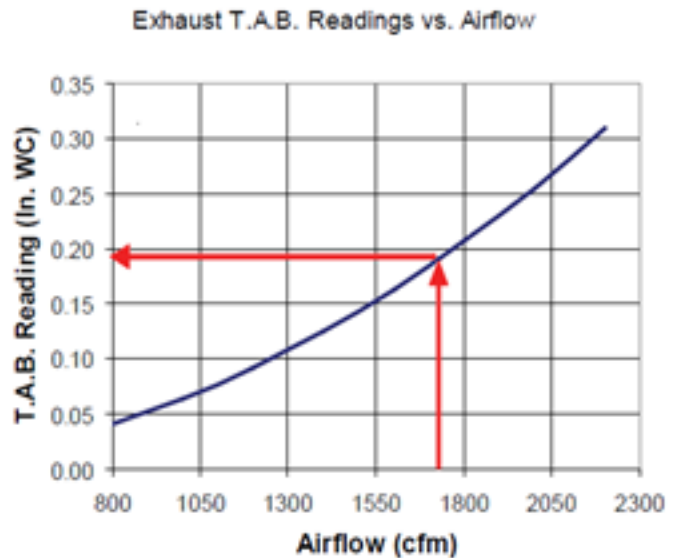

Capture Jet® T.A.B. Port Readings	
Hood Model	Design T.A.B. (inches WC)
KVE/KVC	0.25

Measured Pressure

This example shows how to determine the correct Exhaust T.A.B. port reading for the exhaust hoods.

In this example, a design airflow of 1700 cfm is selected from the Airflow axis, and a vertical line is drawn up to the T.A.B. pressure curve for this hood.

A horizontal line is then drawn for the T.A.B. pressure curve to the T.A.B. reading axis on the left-hand side of the chart and the corresponding pressure is read off the chart as 0.19 inches of Water Column.

- Halton Capture Jet Hoods are equipped with efficient model KSA grease filters. The KSA grease filters must be removed and cleaned by qualified employees of the restaurant owner or by a cleaning agency. Please see detailed instructions on pg. 16 that describe the removal and replacement process.
- Exhaust airflows should be properly set for each exhaust hood, and supply or make up air should be brought into the space to balance the exhaust air leaving the space through the hoods. Kitchen exhaust hoods will not perform according to design if supply or make up air is inadequate. After the exhaust and supply airflows have been properly balanced, a final inspection should be made to ensure proper system operation.

See CONTROL PANEL OPERATION section on page 18 for additional operating instructions.

Cross Section Of Capture Jet™ Water Wash Hood

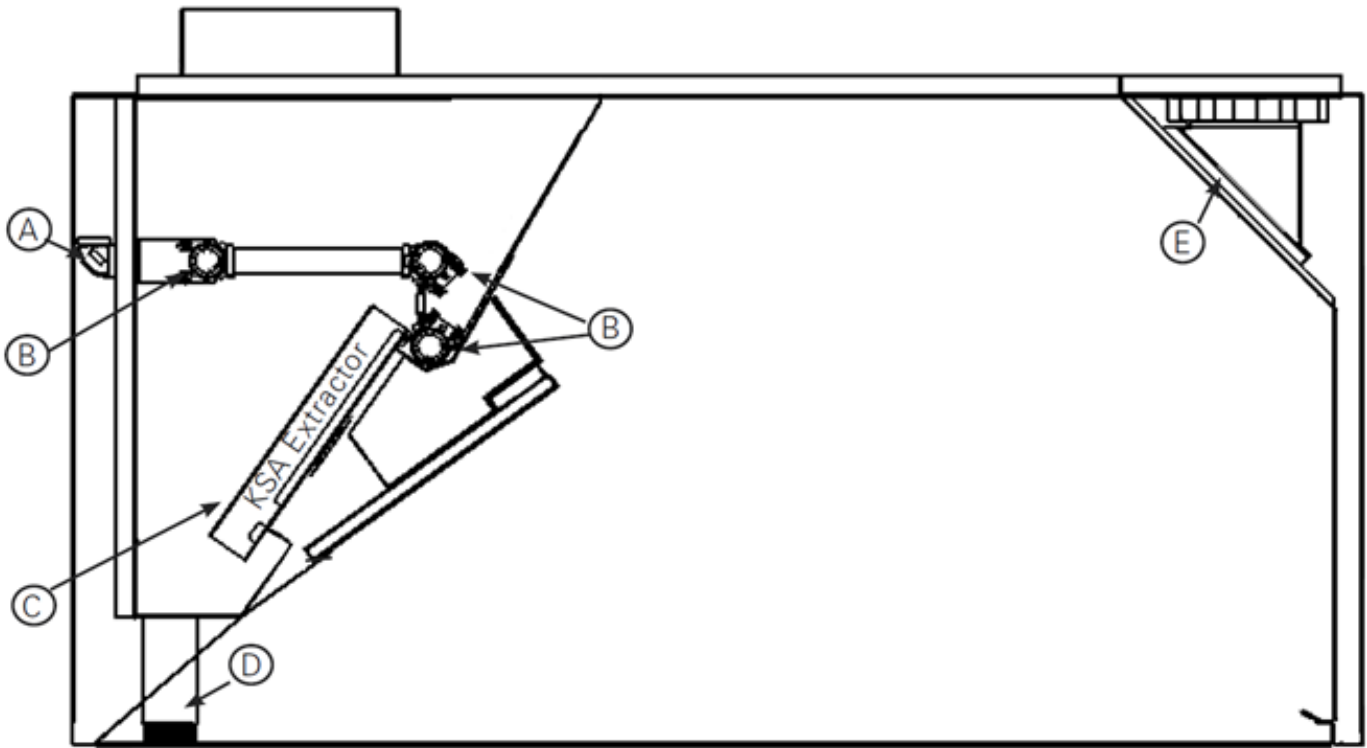

Item	Description
A	Water Wash Intake Supply
B	Water Wash Nozzle Manifolds
C	Multi-cyclone KSA extractor
D	Drain Pipe Connection
E	Capture Jet Fan

Hood Maintenance

Halton highly recommends that the facility enter into a formal annual maintenance contract with the local Authorized Service Agent. Contact the factory directly if you would like the name and phone number of the local ASA.

Clean the hood canopy inside and out as needed with mild soap and water. Never use harsh or abrasive cleaners on Stainless Steel or Painted surfaces, making sure to wipe clean all interior and exterior surfaces of the hood including the light fixtures.

**** Never clean the hood canopy when any of the surfaces are hot.**

The KSA stainless steel filters need to be cleaned regularly. The frequency of cleaning is load dependent. Please see instructions below that describe the removal of the KSA filter and cleaning process.

Halton Water Wash Hood KSA Filter Access and Cleaning

The KSA stainless steel extractors (grease filters) are cleaned during the hood water wash cleaning cycle and should not need to be manually cleaned regularly. The KSA extractors should be inspected quarterly and if build up is detected a manual cleaning may be required. Use the following procedure if grease build up is detected during quarterly inspections. KSA extractors can be soaked in a degreaser overnight and rinsed in the morning before being replaced or they can be run through a commercial dish machine. In order to remove the KSA extractors the KSA Access Panels and the Wash Damper panels must first be removed. To remove each KSA Access Panel remove the two screws in the upper right and upper left corner of each panel. Lift the panel out of the channel the bottom of the panel rests in. Set aside carefully. The Wash Damper panels pivot on a stud at each end of the panel. Rotate the bottom of the panel rearward, towards the KSA extractors, and slide the panel forward removing the damper panel from the pivot studs. There should now be clear access to the KSA primary extractors. Please see instructions below that describe the removal of the KSA primary extractors and cleaning process. After KSA extractors have been cleaned be sure all components have been replaced: The KSA extractors, the Wash Dampers and the KSA Access Panels, in that order. All components must be replaced before the hood is placed back in service. The Wash Dampers and KSA Access Panels prevent water spray from splashing out of the filter plenum area during the wash cycle.

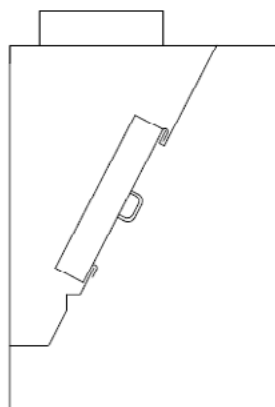
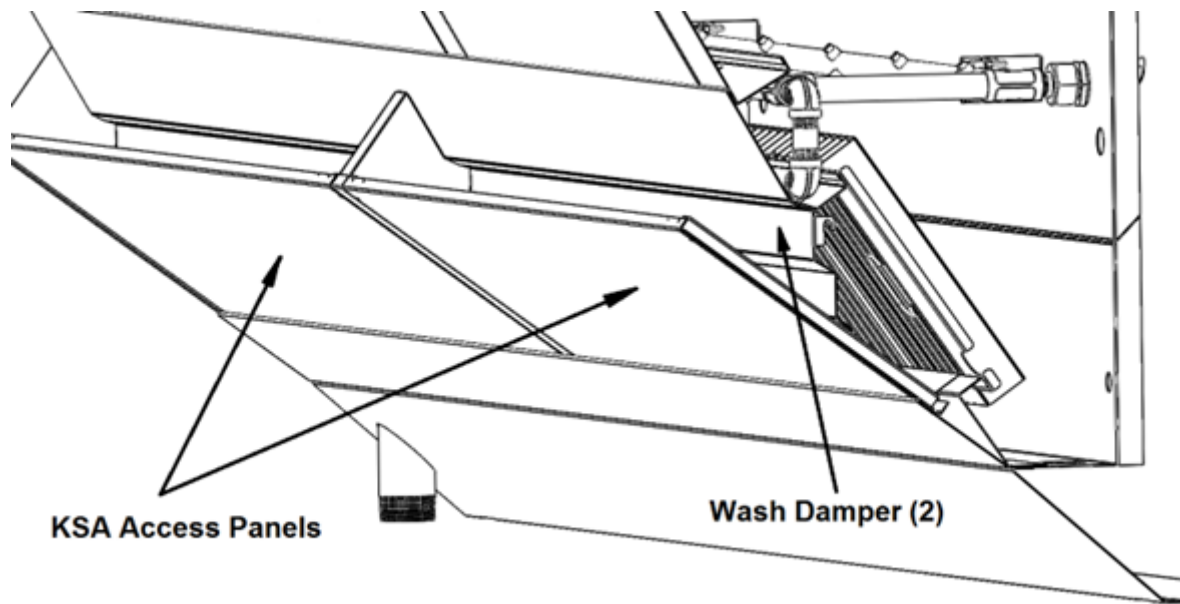

Insert KFR tool

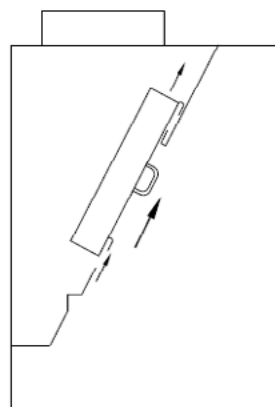

Slide filter up

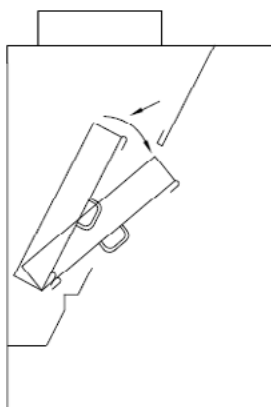

Push filter back and down
Tilt top of filter out

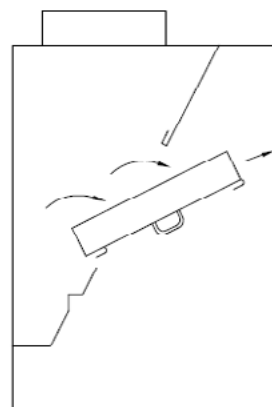

Lift filter out of plenum

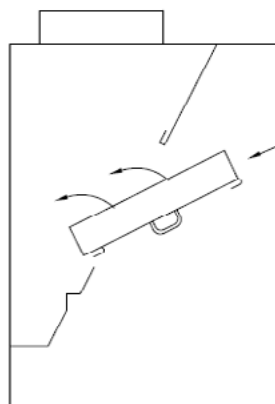

Lift filter into plenum

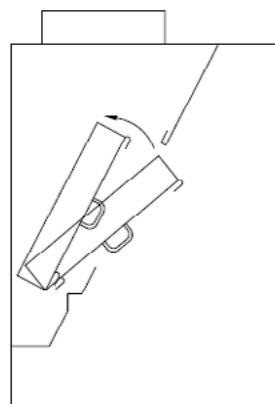

Push filter in and down
Tilt top of filter in

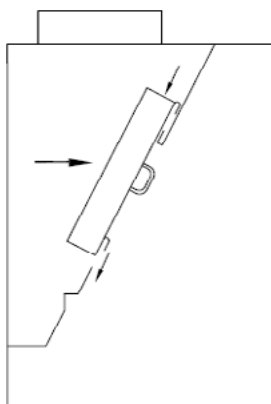

Lift filter to the front
Slide filter down
Remove KFR tool

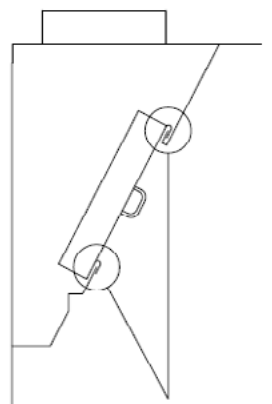

It is Important that the
top lip and bottom lip of
the filter are hooked
correctly

Replacement Parts Schematic

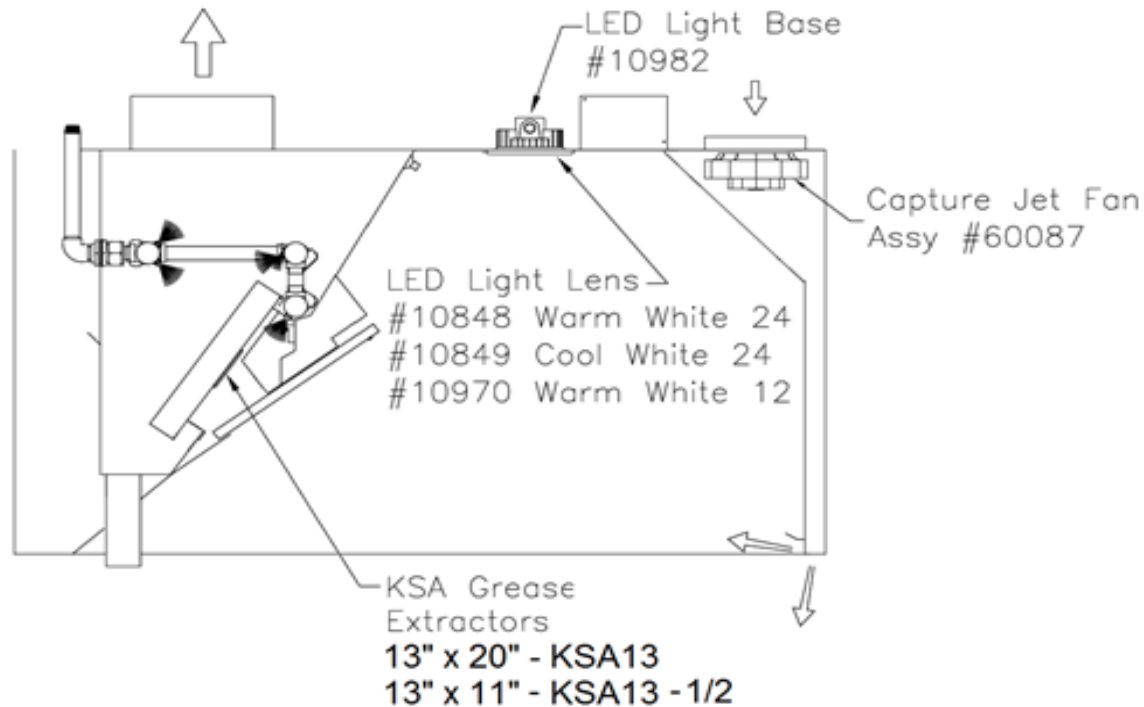

Replacement Part Numbers

KSA Grease Extractor	13" X 20" – KSA13, 13" X 11" – KSA13-1/2
LED Light Base	10982
LED Light Lens	10848 Warm White 24 LEDs 10849 Cool White 24 LEDs 10970 Warm White 12 LEDs

Water Wash Nozzle Information

Two different nozzles are supplied with the Capture Jet Water Wash Hood. Replacement nozzles are obtained from Spraying Systems Co. Catalog number B5 nozzle washes the top of the grease plenum, the back of the KSA filters, the front of the KSA grease filter, and make up a portion of the nozzles in the wash manifold that washes the inside of the KSA grease filter. The B5 nozzles have an inlet connection size of 1/8", orifice diameter 0.031". The balance of the nozzles which wash the inside of the KSA grease filter are Catalog number C30. The C30 nozzles have an inlet connection size of 1/8", orifice diameter 0.023". Maximum recommended water pressure is 80 psi, typical water pressure would be 40 psi.

Preventative Maintenance

Preventative maintenance is necessary for efficient operation of your Capture Jet™ Water Wash hood.

Daily - Clean exhaust hood exterior. See cleaning exterior. Run the hood wash cycle.

Monthly - Inspect filters for grease accumulation and clean if required. Although this is listed as monthly, it may be extended or shortened depending on the type of cooking and hours of operation.

Ensure nozzle operation is checked at recommended maintenance intervals. Nozzle operation to be verified during monthly cleaning inspection. A visual inspection of the drain condition should be performed at the same time.

Recommendation to **replace wash nozzles annually** to ensure optimal performance (replaced as needed if performance issues are noted during monthly inspection).

Control Panel Operation

The Water Wash control panel is designed to operate only under safe conditions and warn when there are fan failures or other operational failures.



The control panel features a user friendly touch screen interface. The following illustrations depict the navigation and features of the touch screen.

Note: Touch screen examples shown below are for the basic Water Wash system.

This touch screen allows the user to scroll the screen up and down to view the entirety of the home page or any of the pages. Certain selections have pull down menus to access different features of the selection.

Below illustration shows the main features of the home screen, which can be accessed from any subsequent screen by pressing the “Home” icon at the bottom center of the screen.

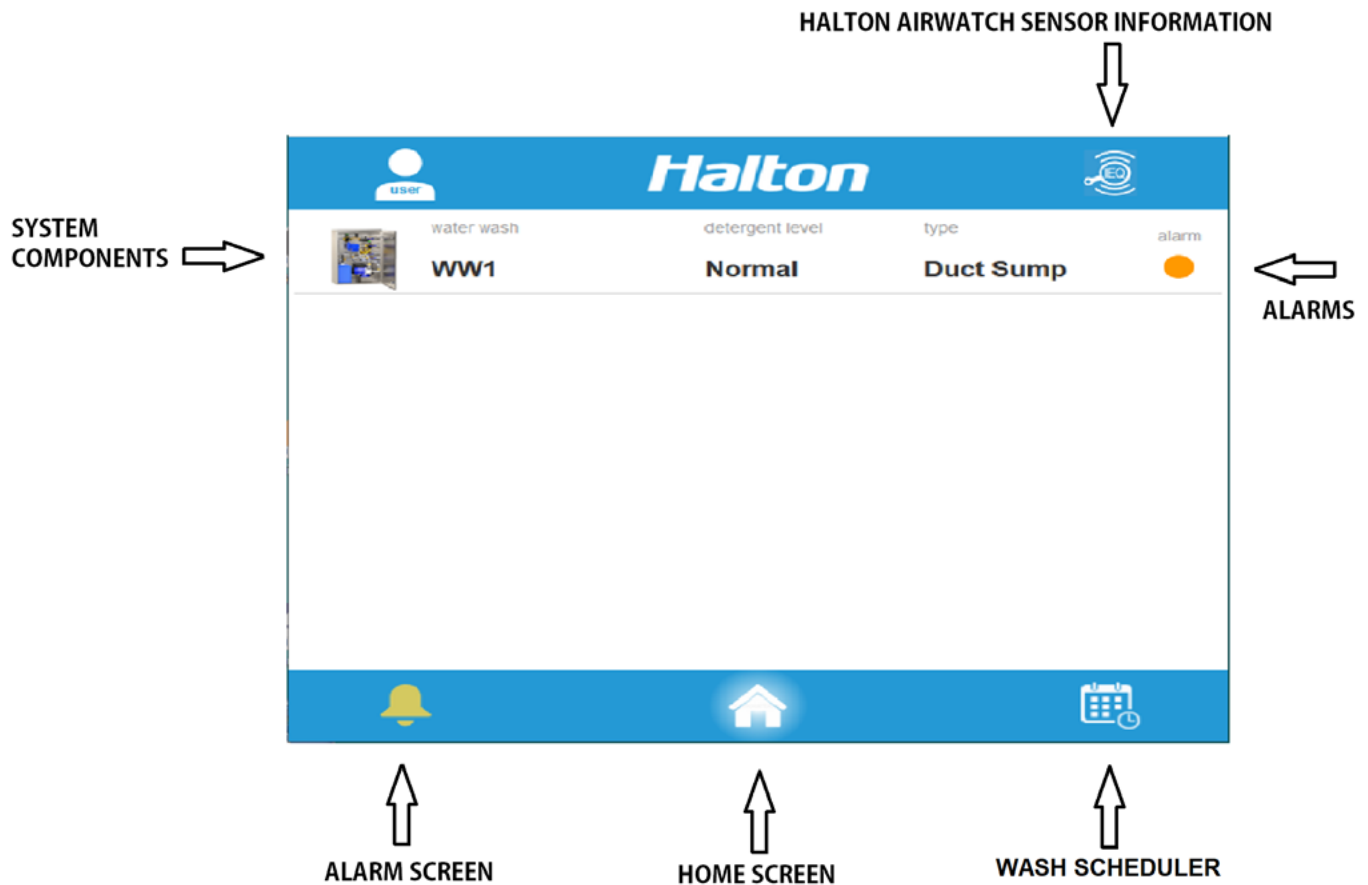

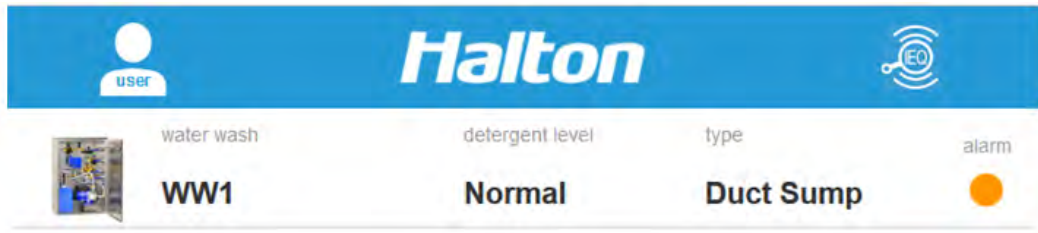

Home Screen for Water Wash Panel number 1 (WW1)

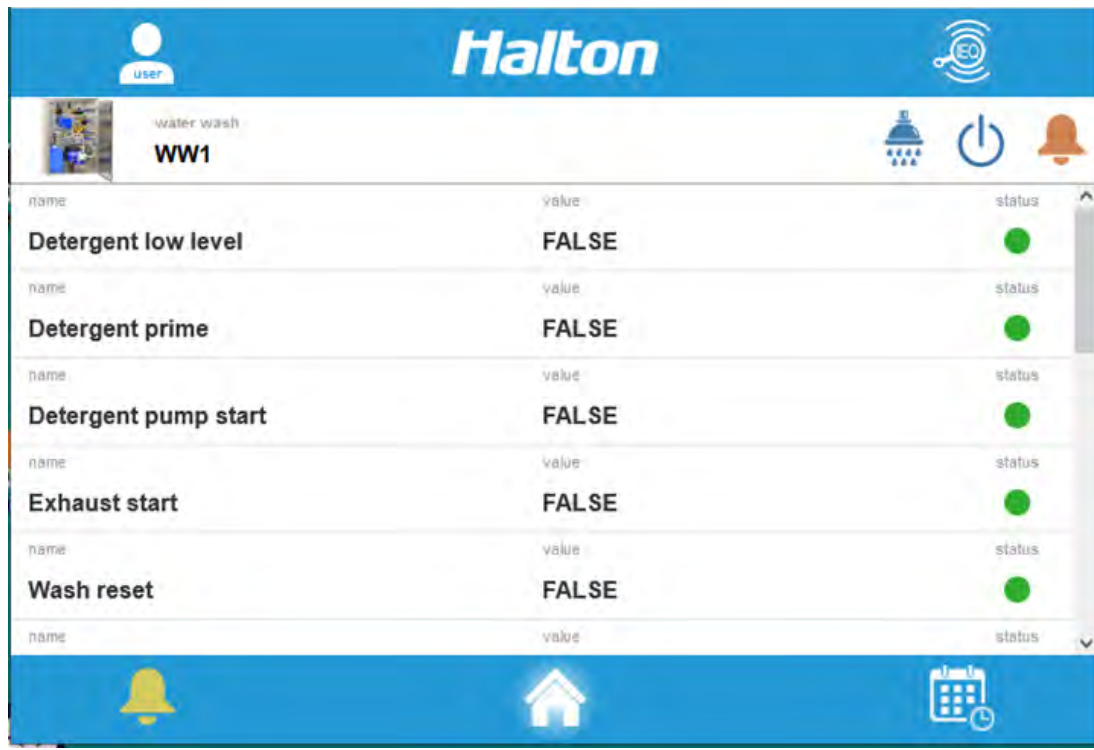

Touch “WW1” icon to drill down into menu. Menu items are scroll able. Scroll down for more items displayed. Use scroll bar at right of screen.

name	value	status
Detergent low level	FALSE	●
Detergent prime	FALSE	●
Detergent pump start	FALSE	●
Exhaust start	FALSE	●
Wash reset	FALSE	●
Local exhaust start status	FALSE	●
Fire (local signal)	FALSE	●
Motor start	FALSE	●
Solenoid 1 Start	FALSE	●
WW assigned to	Standalone	●
Drip time	10.0 sec	●
Fan time	22.0 sec	●
Scheduled start	FALSE	●
Wash start delay	11.0 sec	●
Wash type	Normal	●

Menu items are scroll able. Scroll down for more items displayed. This is an expanded view of all items (these cannot all be displayed on the touchscreen at one time because of the limited size of the screen).

Alarm Screen

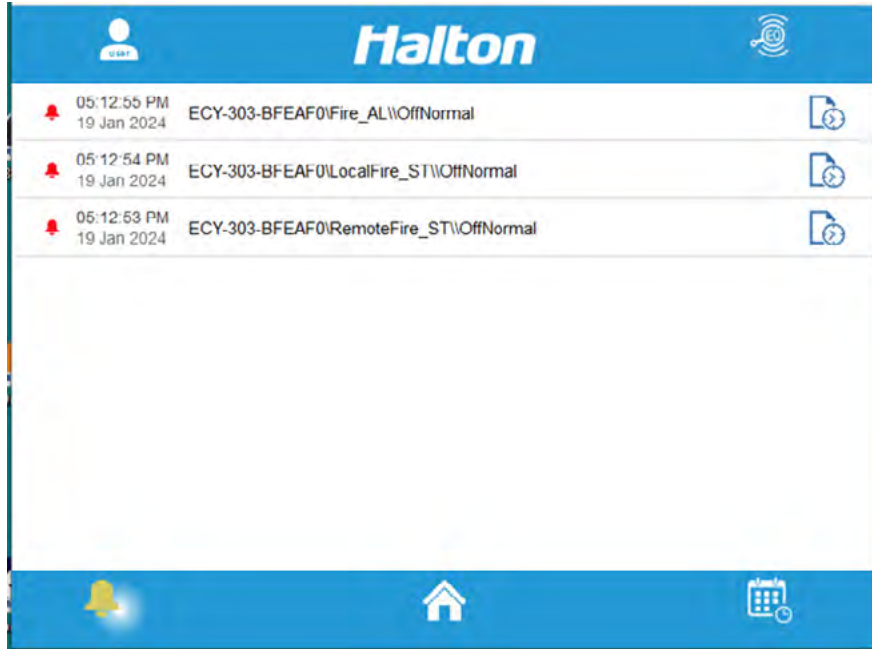

This screen is accessed from the “Alarm” icon in the lower left corner of the display. This screen will display your current alarms along with the alarm history.



Touching the icon on the right of the alarm event will display details about each alarm



active alarm



inactive alarm



historical records

Schedules



Touching the schedule icon at the bottom right of the screen will display the Schedule screen. You may choose between Occupancy Schedule and Wash Schedule.

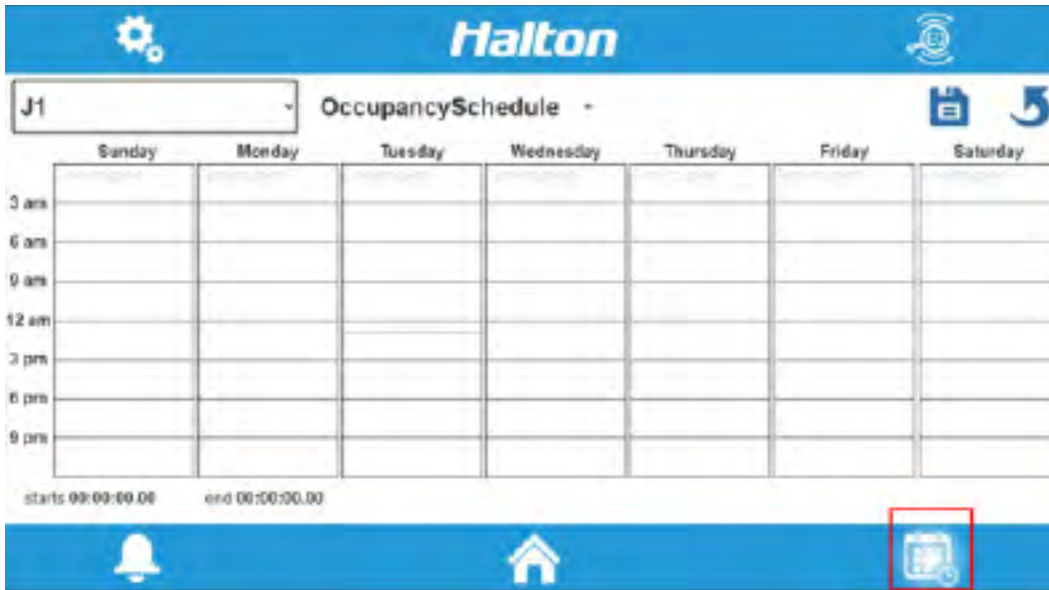

Select product from dropdown menu number one. Select schedule type from drop down menu number two.



Edit the selected schedule by creating new events or modifying existing events. Right click on a day of the week, select “Create Event” to create new event. Drag the border of the event to modify the duration time of the event.

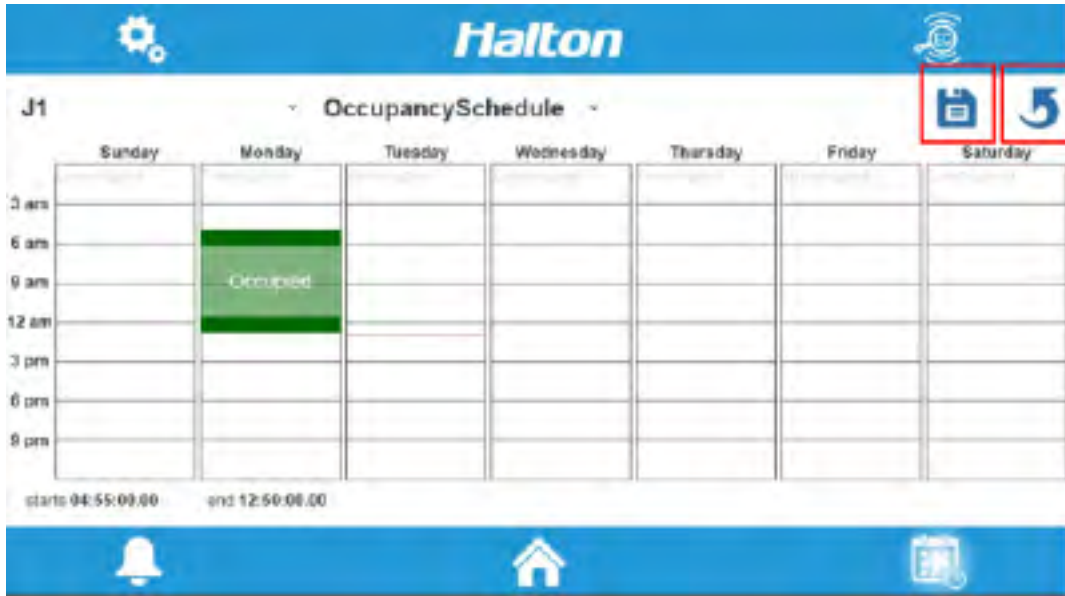

Save the modified schedule by clicking save icon. Reload/refresh the schedule by clicking reload icon.

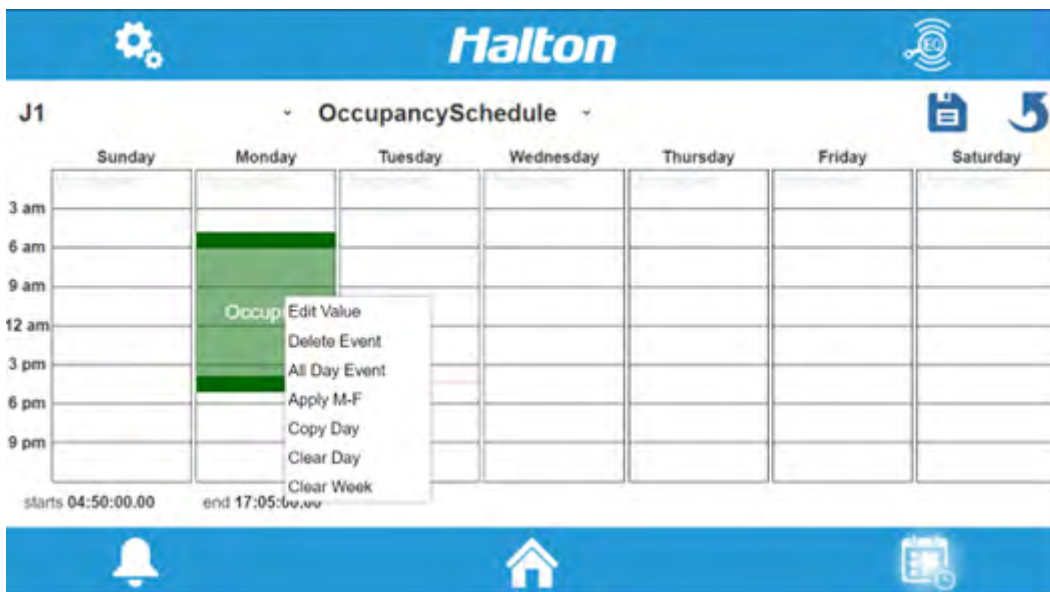

Edit or delete an event from the schedule by right click on the event and selecting “Edit Value” or “Delete Event”.

J1

WashSchedule

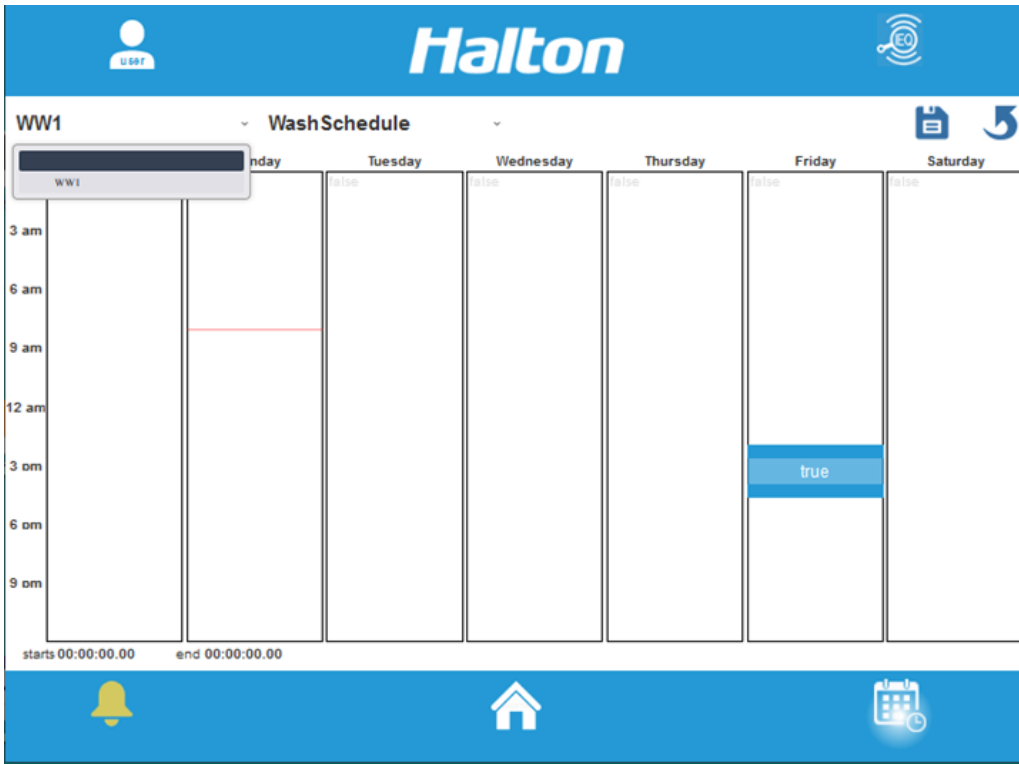

Wash Schedule Screen

Wait for schedule to populate information.

A NOTE ABOUT WASH CYCLE TIMES

The length of the wash cycle is preset at the factory. Under extreme conditions such as heavy duty appliances or if hot water supply is located some distance from ventilators, it may be necessary to increase the length of the wash cycle. This adjustment must be performed by Halton Service Department. The adjustment may be performed remotely if the Halton hood is equipped with an Edge device for remote access, or in person if not equipped.

1. Wash Occurs - length of this wash can be adjusted (factory set for 60 seconds)
2. Draining Occurs – 60 seconds and cannot be changed
3. Rinse Occurs – length of this rinse can be adjusted (factory set for 60 seconds)
4. Fan Dry – 3600 seconds (one hour) and cannot be changed

Press screen and hold the press until the menu appears. This allows you to create an event (schedule a wash for example), and apply the event to the desired days of the week. You may also copy a day's schedule to another day, clear the schedule from a day or clear the schedule for the entire week.

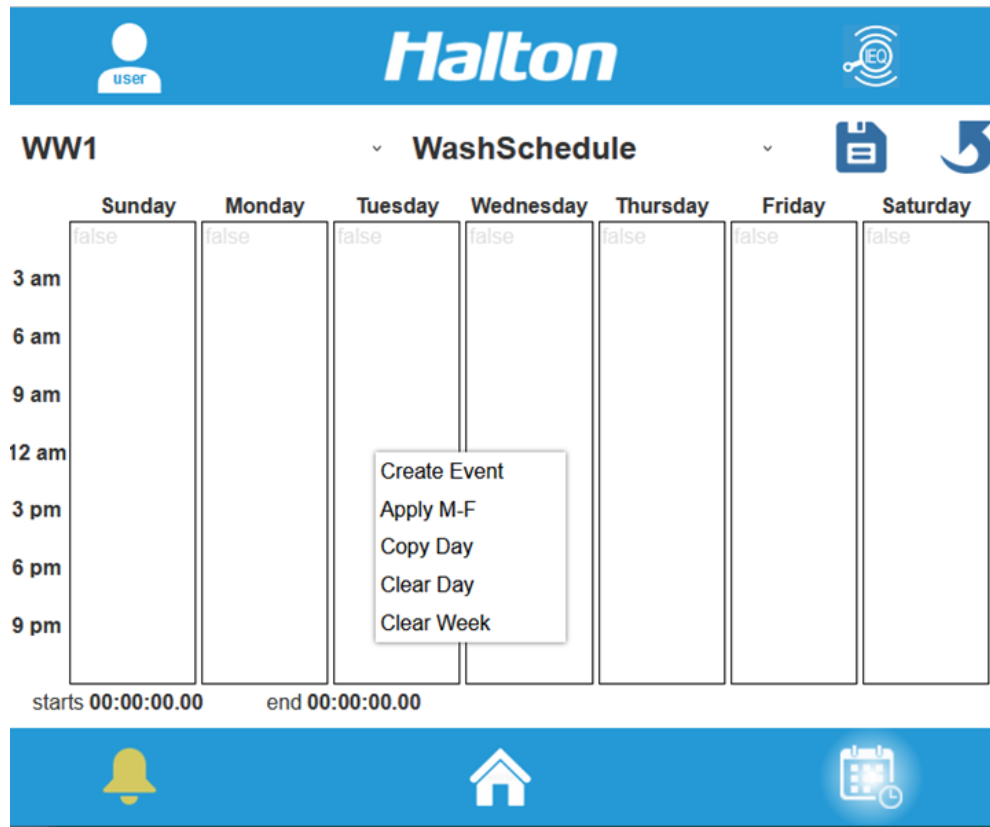

Wash Schedule Screen

When the event appears press and hold the event and the Edit Event menu appears. You may perform the functions in the Edit Event menu by pressing the desired function in the menu. You may drag the dark bars at the top or bottom of the event to adjust start and stop points for the event. When selecting “Edit Value” you have the choice of “false” and “true”. “False means “No Action” or “Off”, while “True” means “Action activated” or “On”. Press “True” to activate the event in the schedule.

Repeat creating events for additional wash functions as desired. Press the “Home” icon to save changes and return to the home screen.



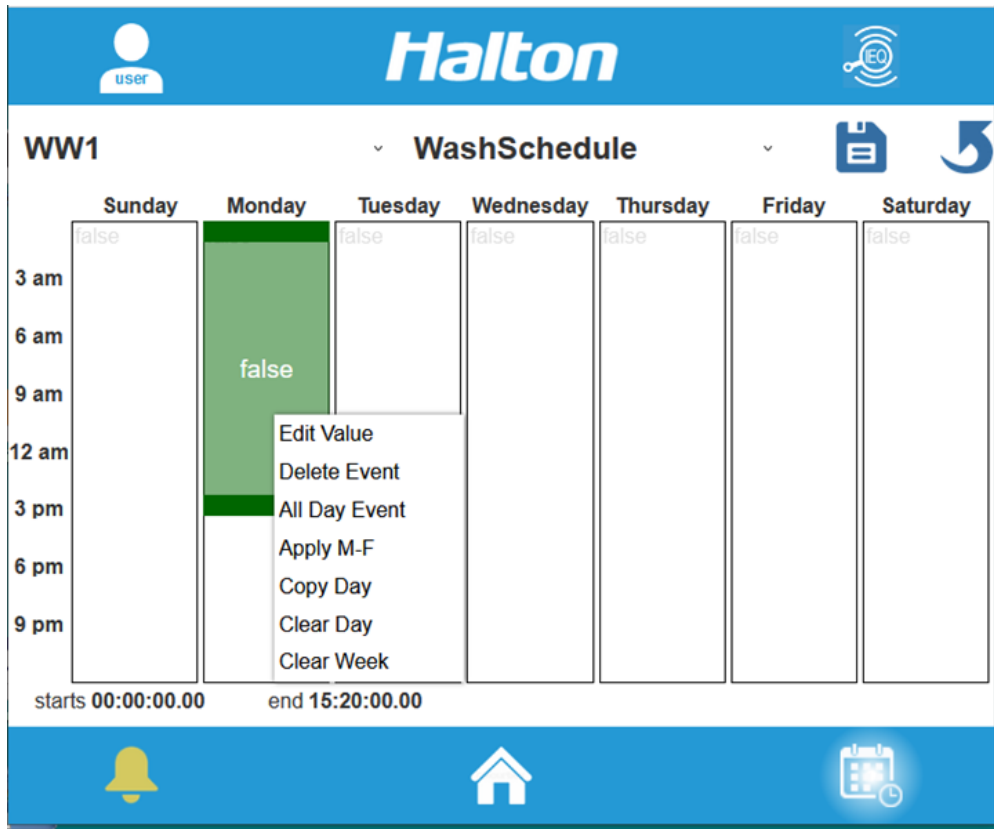

Wash Schedule Screen

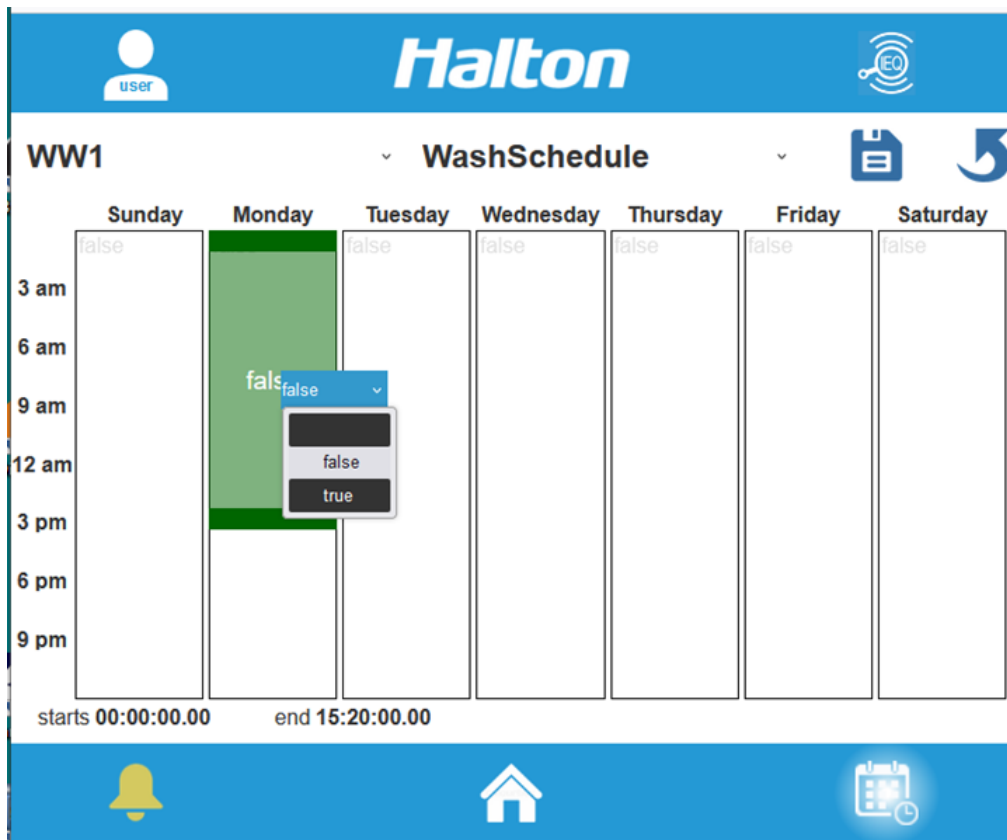

Wash Schedule Screen

Electrical Wiring/Connections

A Field wiring diagram is shown below. Please see wiring diagrams included with the job specific submittal drawing for point to point connection diagram.

Field Wiring Diagram

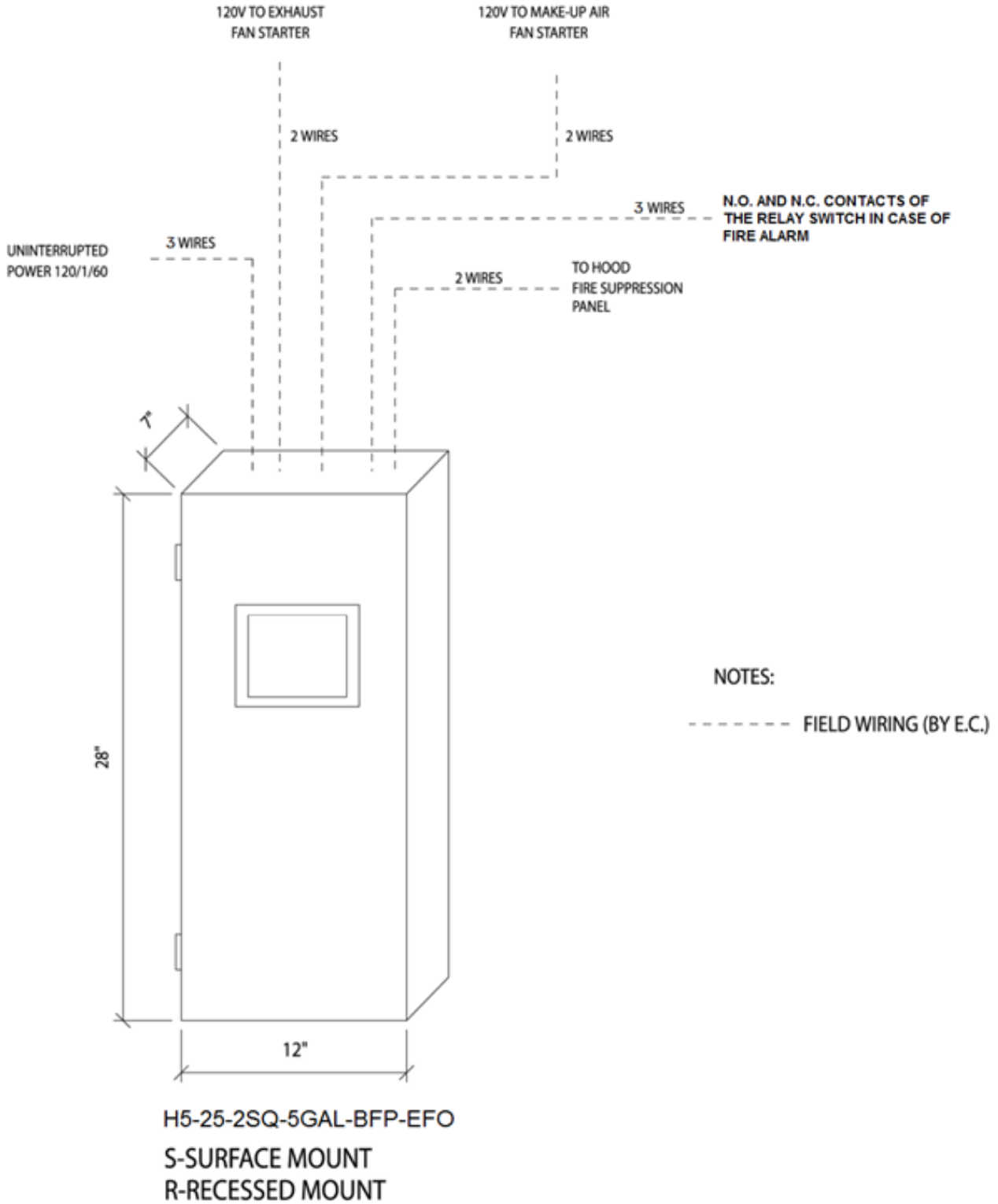

WARRANTY FORM

This form must be completed and returned to Halton in order for your warranty to be valid.

Job & Location Information:

Job Name: _____

Street Name: _____

City: _____ State: _____ Zip Code: _____

Equipment Start-Up Date: _____ Product Serial Numbers: _____

Contact Information:

Contact Name: _____

Title: _____

Chef, Kitchen Mgr/Facility Mgr/Property Mgr/etc.

Facility Management Company Name (if applicable): _____

Email: _____

Phone Number: _____ Cell Number: _____

Fax completed form to:
Halton Company
Attention: Service Department
Fax: (270) 237-5700

Halton Indoor Climate Systems
Attention: Service Department
Fax: (905) 624-5547

Halton Limited Warranty

Halton (“Manufacturer”). Warrants only to its direct purchasers and to no others, that all products manufactured by the Manufacturer shall be free from defect in materials and workmanship for a period of twelve (12) months from the date of the original installation and start-up or eighteen (18) months from date of shipment, whichever occurs first. All products sold but not manufactured by Manufacturer will be warranted for a period of twelve (12) months from date of shipment.

For products manufactured by the Manufacturer we agree to pay any reasonable labor costs necessary to repair or replace, at Manufacturers option, defective parts or materials for a period of twelve (12) months from date of original installation and start-up or eighteen (18) months from date of shipment, whichever occurs first. All labor costs subject hereto shall be performed during standard work hours at straight-time rates.

For products sold but not manufactured by the Manufacturer we agree to pay any reasonable labor costs necessary to repair or replace, at Manufacturers option, defective parts or materials for a period of (90) days from date of original installation and start-up or (12) months from date of shipment, whichever occurs first. All labor costs subject hereto shall be performed during standard work hours at straight time rates.

All warranty claims that include labor requires pre-approval by Halton. Halton, at its discretion, will authorize field warranty work through its own service network or certified third party. No claims for labor charges will be approved for payment if work commences without prior authorization by Halton.

Purchaser shall pay incurred premium labor charge, including overtime, weekends and holidays. Travel time, service charges, miscellaneous tools, material charges, and labor charges resulting from inaccessibility of equipment will not be paid by Manufacturer.

This LIMITED WARRANTY SHALL APPLY ONLY to products that have been installed and maintained in accordance with the installation and Care Instruction Manuals. Purchaser shall be solely responsible for adhering to the instructions and procedures set forth in the said instruction manuals.

This LIMITED WARRANTY SHALL NOT BE APPLICABLE to any damage or defect resulting from fire, flood, freezing or any Act of God, abuse, misuse, accident, neglect or failure to adhere to all instructions set forth in the installation and Care Instruction Manuals. Furthermore, this limited warranty shall not apply to any product that has been altered, unless such alteration has been approved in writing by a duly authorized representative of the manufacturer. In no event shall the manufacturer be liable for any loss, expense, personal injury or consequential damage, of any kind or character, as may result from a defect in material, and/or workmanship, however caused.

EXCEPT AS IS EXPRESSLY SET FORTH IN THIS LIMITED WARRANTY, MANUFACTURER MAKES NO WARRANTY OF MARKETABILITY FOR FITNESS OR ANY PARTICULAR PURPOSE. NEITHER DOES MANUFACTURER MAKE ANY WARRANTY, EXPRESSED OR IMPLIED, WITH RESPECT TO PRODUCTS SOLD BY MANUFACTURER OR AS TO THE USE THEREOF.

Continuous product improvement is a Halton policy, therefore specifications and design are subject to change without notice.