

Operators Manual for PolluStop Pollution Control Unit

Manual provides
Installation, Operation, Maintenance and Service Instructions



PolluStop - PST

3000CFM, 4000CFM, 5000CFM, 6000CFM, 8000CFM,
10000CFM, 12000CFM, 15000CFM, 18000CFM,
20000CFM, 24000CFM, 28000CFM, 32000CFM,
36000CFM, 40000CFM

MAJOR COMPONENTS FOR POLLUSTOP may include:

- Inlet Transition (optional)
- Electrostatic Precipitator (ESP) Module with Coarse and Fine ESP Cells
 Single Pass, Double Pass or Triple Pass
- 2 stage Filtration Module (Extended Life Filter (ELF) plus Absolute Filter)
- Charcoal V Bank Panels with Optional bank of UV lamps & UV power pack
- Heat Recovery Module
- UV light/Carbon Module
- Carbon only Module
- Scentry Deodorant Solution Odor Control Module
- Fan/Blower Module (Standard, Upblast or Inline)
- Silencer Module

Standard Accessories for Electrostatic Precipitator Module (ESP) include: (remote/field mounted)

- Power pack
- Variable Frequency Drive
- Detergent
- 5 Gallon Concentrated Detergent Dispenser
- High Voltage Cable
- M.A.R.V.E.L. Control Panel (Distech PLC System Control)



The Power Pack, System Control, and Detergent Dispenser must be mounted indoors, protected from weather elements, in a location easily accessed and monitored by operating/ service personnel.

Table of Content

Safety Information	5
Specific Safety Precautions	6
Model Number Development	8
General Requirements	9
FILTER MODULE	10
Air Filter Installation	11
Filter Modules	11
Filter Module Overview	12
ESP MODULE	14
ESP Module Overview	15
High Voltage Power Supply (HVPS or Power Pack)	18
Initial Start-Up of ESP Module	22
UV/CARBON MODULE	25
UV/Carbon Module Overview	26
UV Bulb Status Indicator Panel	27
Carbon Panels	27
Module Installation	28
Electrical Connections	28
120 Volt and UV Control Wiring	29
Odor Sensor Reporting	30
ULTRA VIOLET (UV) Operations	30
With UV Module Sequence of Operation	30
PolluStop With UV	30
ODOR	31
PolluStop Odor Control	32
HRU (HEAT RECOVERY UNIT) MODULE	33
Heat Recovery (HRU) Module Illustration	34
FAN MODULE	35
Fan Section	36
CONTROL PANEL	37
PolluStop Control Panel	38
Control Panel Features	39
Main Components of the Control Panel	39
How to move around the screens in HMI	40
Main Screen	40
Calibration Screen	40
Ecolo Screen	40
Filter Integrity Monitor (FIM)	40
Alarm Screen	41
Security Screen	41
User Guide Screen	41
Touch Screen Operation	42
How to calibrate the system during start up by using HMI	44
ADDITIONAL SCREENS FOR CONTROL PANEL FOR SYSTEMS WITH ESP	47
Automatic Operation	49

Setting Clock	49
System Operating Schedule	49
System Wash Schedule	49
ASSEMBLY INSTRUCTIONS	50
Connection of Inlet Transtion/Exit Ductwork	51
Field Connection of Modules	52
Electrical Connections	53
Schematic Wiring Diagrams	53
Start Up Notice for units without ESP Module	54
Start Up Operating Instructions	54
Start Up Check List	55
MAINTENANCE	57
Maintenance Instructions	58
Routine Maintenance	58
Filter Section Maintenance	60
Filter Replacement	61
Filter Quantity Chart	61
Filter Integrity Monitor (FIM)	62
Pressure Transducer Air Tube Parts	63
ESP Module Maintenance	64
Operation and Maintenance	65
Introduction	65
Operation	65
Washing	65
Halton's PLC control is pre-programed to manually	65
Reset Mode	65
Detergent Dispenser	67
General	67
Adjustments	67
Detergent	67
Detergent Cabinet	67
Maintenance	67
Ionizer-Collector Cell Maintenance	68
UV/Carbon Panel Maintenance	69
UV Cassette Maintenance & Replacement	70
Odor Maintenance	72
Preparing Odor Control	74
Setting Ecolo Time On and Time Off Cycle	75
Fan Section Maintenance	76
Fan Wheel Replacement	77
Bearing Replacement	77
Exhaust Fan Module	78
Fan Types	78
Sheave Alignment	79
Belt Adjustment	80
Troubleshooting Guide	81
Warranty Activation Form	83
Halton Limited Warranty	84

Safety Information

The instructions contained in this manual have been prepared to aid you in learning the proper procedures for installing and servicing your unit.

Throughout this manual, safety precautions are identified through the use of the safety alert symbol and three signal words: DANGER, WARNING, and CAUTION. All safety alert information precedes the step(s) to which they apply. Suggested, recommended, or other noteworthy information is identified through the use of NOTES. Additionally, certain words are used to indicate a specific meaning or to add emphasis.

The following words are used as indicated throughout the manual:

Shall: understood to be mandatory.

Should: understood to be advisory.

May: understood to be permissive.

Will: indicates a future event/condition to occur.

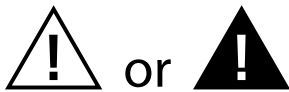

(Safety Alert Symbol)

Used in conjunction with signal words (DANGER, WARNING, or CAUTION) to alert you of potential personal injury hazards, immediately preceding precautionary measures that pertain to subsequent step(s). Obey all safety messages that follow this symbol to avoid possible injury or death. Failure to adhere to safety precautions identified by the safety alert symbol may also void the warranty.



- Indicates an imminently hazardous situation which, if not avoided, will result in death or serious injury. Use of this is limited to the most extreme situations.



- Indicates a potentially hazardous situation which, if not avoided, could result in death or serious injury.



- Indicates a potentially hazardous situation which, if not avoided, may result in minor or moderate injury. Also used to alert against unsafe practices.



- When used without the safety alert symbol, CAUTION indicates a potentially hazardous situation which, if not avoided, may result in equipment/property damage, and void the warranty.

NOTE:

- Identifies suggested, recommended, or other noteworthy information.

Specific Safety Precautions

For your safety, please observe the following precautions when operating or servicing your system. Read the following important safety information to avoid personal injury and/or damage to the equipment.

DANGER

- Always disconnect the source of the main power before removing the service entrance box cover.
- Failure to ensure the Power switch is in the “OFF” position during servicing and when replacing filters could result in equipment damage, electrical shock and/or personal injury.
- Failure to comply with these DANGER notices will result in death or serious injury, equipment/property damage, and void the warranty.

WARNING

- DO NOT use or store flammable liquids or materials that produce flammable vapors in the vicinity of this or any other appliance!
- Consult a qualified electrician to ensure all electrical specifications have been met and the unit is properly grounded.
- Before installing or servicing this equipment, read the contents of this manual thoroughly.
- Improper installation, adjustment, alteration, service or maintenance could result in death or serious injury, equipment/property damage, and void the warranty.
- Failure to comply with these WARNING notices could result in death or serious injury and equipment or property damage.

WARNING

- Internal ultraviolet radiation source present.
- Keep protective barrier in place.
- Replace all removable parts after servicing.
- An interlock is in place to reduce the potential of exposure to excessive ultraviolet radiation. DO NOT attempt defeat or bypass this interlock system.

CAUTION

- Exercise care when removing the wooden crating from around the unit.

CAUTION

- DO NOT operate the unit unless you fully understand the components and their intended function.
- Failure to comply with these CAUTION notices may result in minor or moderate injury, equipment or property damage, and void the warranty.

CAUTION

- The electronic components of the Control Panel are impact-sensitive. Exercise care around the Control Panel to maintain proper operation.
- During cleaning of Hood.
 - DO NOT use products containing chlorine.
 - DO NOT use abrasive products, steel wool or scouring pads.
- Failure to comply with these CAUTION notices may result in equipment/property damage and void the warranty.

NOTE:

- If upon receipt, the palletized unit shows any signs of damaged, immediately inspect the entire Hood and the included accessories, and promptly notify the freight company of any damages.
- To aid the electrician, an electrical wiring diagram is included with this manual. Refer to the wiring diagram during installation or servicing. A wiring diagram may be obtained from the factory by calling Halton at 270-236-5600
- Comply with all appropriate state and/or local health regulations regarding the cleaning and sanitation of equipment.
- For difficult areas with excessive particulate build up, a mild bio-degradable non-toxic degreaser (such as Clear Magic or Simple Green) may be used.
- Always ensure the unit is electrically grounded and installed in accordance with local codes, or in the absence of local codes, in accordance with the National Electrical Code ANSI/NFPA No. 70-1984.

NOTE:

- An HVAC specialist may be required for some installations to confirm proper air exchange and the heat load capabilities of the on-site AC system.

CAUTION

- Use suitable equipment to lift the hood and carefully move it away from the pallet. Take precautions not to damage to the hood. If possible, it is advisable to rig and lift the hood from the topside, utilizing the hood's hanging brackets.

- Exercise care when removing the wooden framing from around the unit.
- Failure to comply with these CAUTION notices may result in minor or moderate injury, equipment or property damage, and void the warranty.

CAUTION

- DO NOT MODIFY, ALTER OR ADD ATTACHMENTSTOTHIS EQUIPMENT

NOTE:

- INSTALLATION OF THIS UNIT(S) MUST BE IN ACCORDANCE WITH NFPA 96, STANDARD FOR VENTILATION CONTROL AND FIRE PROTECTION OF COMMERCIAL COOKING OPERATIONS AND (IN CANADA) ULC-S650, STANDARD FOR THE INSTALLATION AND PERFORMANCE OF VENTILATION AND FIRE SUPPRESSION SYSTEMS FOR COMMERCIAL AND INSTITUTIONAL COOKING EQUIPMENT.
- AIR FLOW EXITING THIS UNIT IS TO BE EXHAUSTED OUTDOORS.

Model Number Development

MODELS - PST followed by 3,4,5,8,10,12,15,18,20,24,28,32,36, or 40 (based on cfm 3 is 3000 etc.); may be followed by ESP, ELF, ABS, OCUV, OCC, OCS, HRU.

ESP	Electro Static Precipitator
ELF	Extended Life Filter
ABS	Absolute Filter
OCUV	Odor Control using Ultra Violet light with Carbon
OCC	Odor Control using Carbon
OCS	Odor Control Spray (Deodorant)
HRU	Heat Recovery Unit

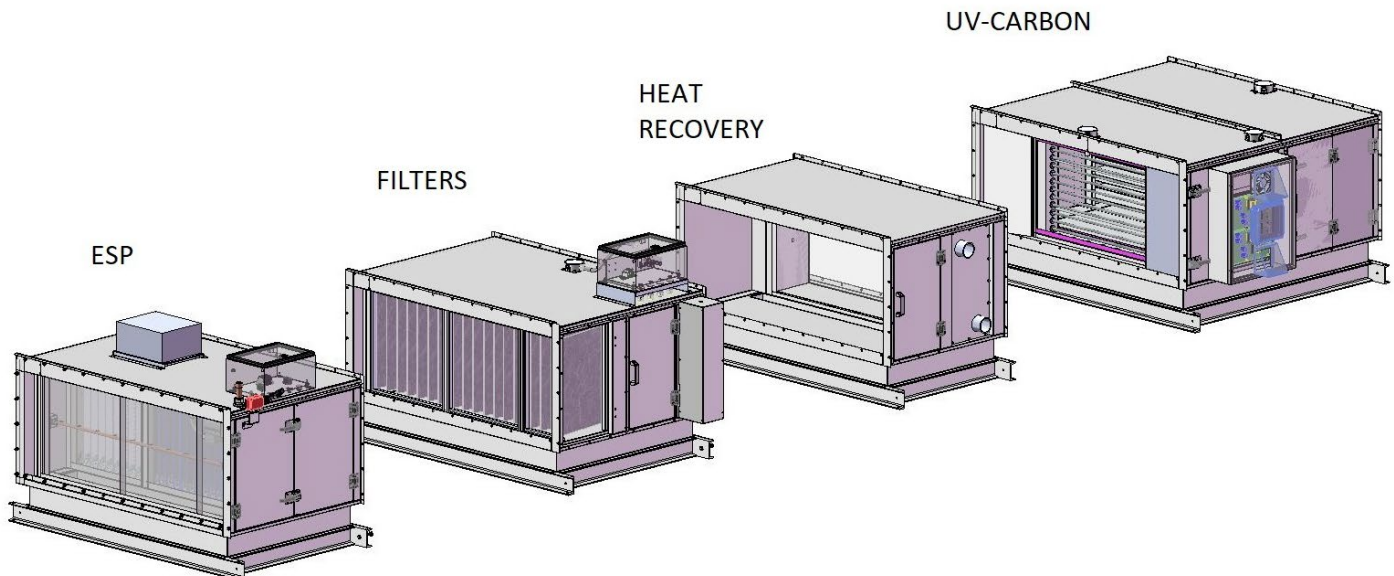

General Requirements

Read this entire manual before beginning installation. Contact the factory with any questions you may have after you have read these instructions. See the contact information at the end of this manual. This illustration shows the relationship between the major modules of the PolluStop system. The modules may be installed together or separated by ductwork. The connecting ductwork between modules, if used, must be 16 gauge liquid tight construction conforming to the standards described in NFPA 96. The ductwork must be fastened to the modules according to the instructions and methods described in that standard and in local codes. Inlet and Outlet transitions from the modules to the ductwork connecting separated modules are recommended in this case. If modules are installed connected directly together see section "Assembly Instructions" starting on page 46. See section below labeled "DUCT CONNECTIONS" for details about inlet and exhaust duct connections. The illustration below shows a horizontal arrangement of modules. The modules may also be arranged vertically in some instances. Other custom arrangements may also be approved, such as stacked or multi-level.

NOTE: When required, equipment shall be seismically restrained per SMACNA and Uniform Mechanical Code. Fabricated support platforms for roof-mounted equipment shall be sized to accommodate the equipment frame and engineered to support the unit's weight indicated on submittal drawings and the weight of associated components such as ductwork, per local and International Mechanical Code (IMC) requirements. Support pads or curbs should be fabricated to fit actual equipment. Verify measurements of equipment frames are accurate before construction of support pads or curbs. The foundation should be flat and level from side to-side and front-to-back. Equipment may be anchored using provided mounting tabs, or by other means which satisfies local and IMC codes. All support pad or curb engineering, design and construction is the responsibility of purchaser, contractor or assigned second party. Halton cannot provide engineering or design for equipment pads, curbs or supporting structures.

If unit is to be hoisted or lifted the Hoist contractor must use own expertise/experience when rigging for lifting. Spreader bars or other acceptable methods should be used to prevent damage to the unit while lifting. Halton takes no position that it will advise best practices for overhead lifting. Anchor points may be used for rigging or anchoring to the floor, pad or mezzanine, or for overhead suspension.

Clearance from the all PST modules to nearby materials is per NFPA 96 guidelines: 18" to combustibles, 3" to limited combustibles and 0" to non-combustibles. Clearance reduction systems conforming to NFPA 96 and acceptable to the local Authority Having Jurisdiction (AHJ) may be used. Access for maintenance to filters and other components must remain when designing and installing a clearance reduction system.

Note: Minimum of 30" of clearance must be maintained on the access door side of each module to allow maintenance access and service to filters, odor control solution, carbon filter and fan motor/blower components. Please ensure there is adequate clearance in installation location. See submittal documents for additional job specific clearance requirements. Requirements may change based upon which filtration modules are selected for the specific unit being installed. For instance ESP modules may require 42" of clearance to remove the larger Electrostatic Precipitator Cells.

Note: Fire suppression at inlet of filter section must be used based on local fire code requirements. If fire suppression cabinets are factory installed on the unit 36" of clearance must be maintained on the fire suppression cabinet side of the unit, which is usually on the side of the unit opposite the filter access doors.

Filter Module

Air Filter Installation

1. Care should be taken to install the filters in the proper sequence. They should be installed in the following order:
 - a) Beginning at the exhaust inlet, the first filter is the Merv 14 double layer bag filter (ELF Filter)
 - b) Followed by the filter labelled Final Filter, Merv 16
2. All filters should be installed taking note of the arrow indicating the directions of air flow.
3. It is important that all the filters be properly seated, top and bottom, in the filter supporting frames for each filter as shown in figure 4.

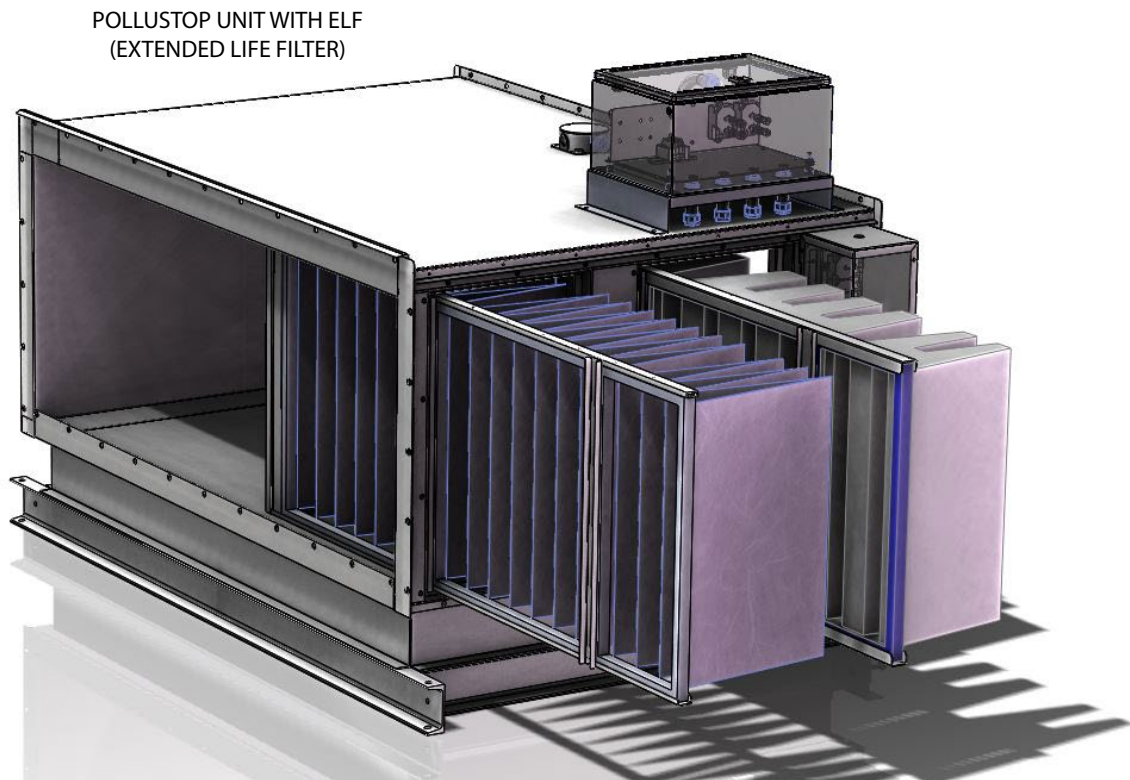

Filter Modules

The filter module is made up of the following:

1. ELF (Extended Life Filter) A 15" deep (381 mm) MERV 14 (Minimum Efficiency Reporting Value) patent pending, extra capacity bag filter, Classified UL 900 filter.
2. A 12" deep (305 mm) MERV 16 (Minimum Efficiency Reporting Value) Classified UL 900 Final Filter
3. Filter Integrity Monitor (FIM)

Filter Module Overview

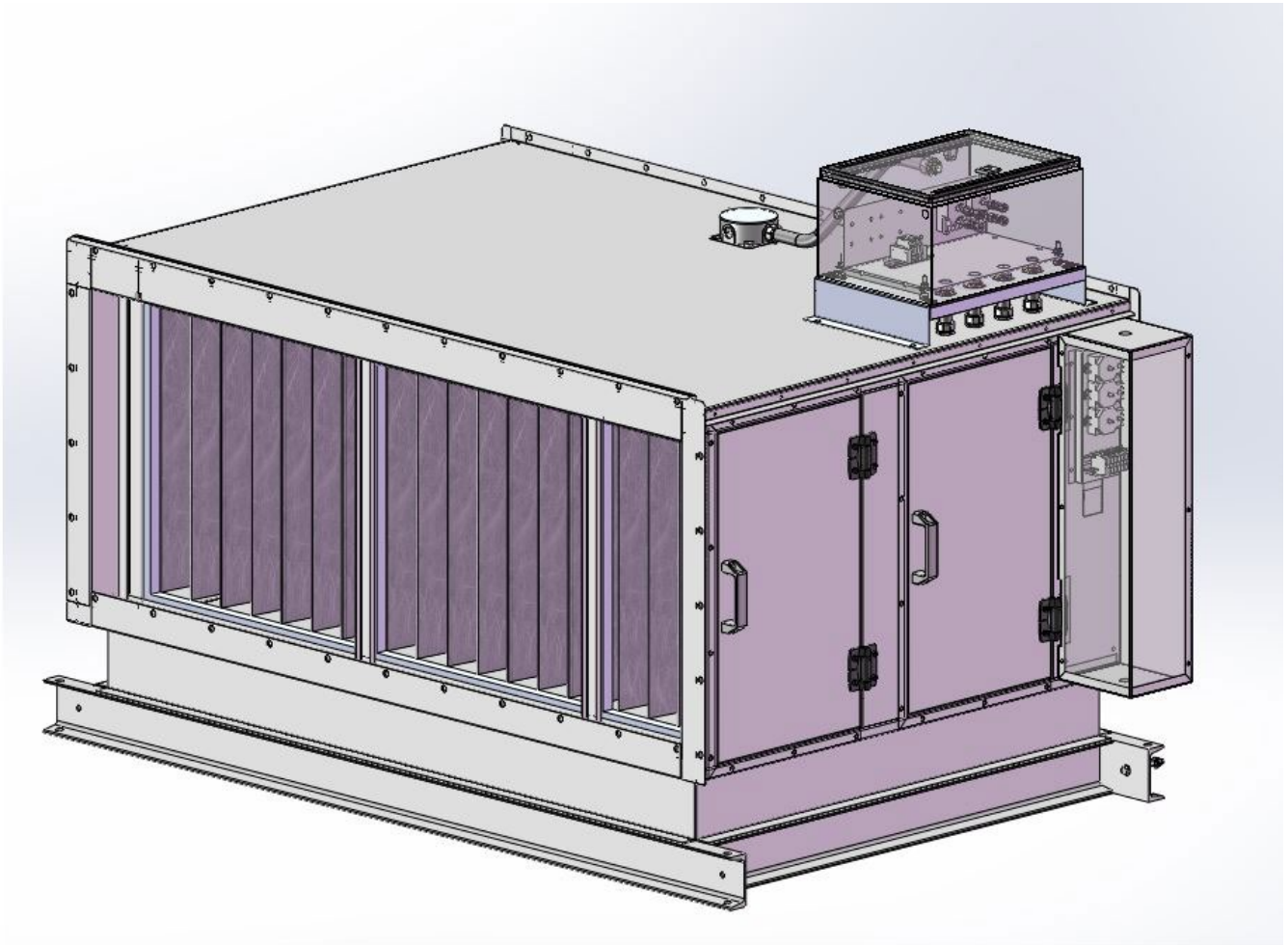

PolluStop Filter Quantity Chart

MODEL	CAPACITY	ELF BAG FILTER MERV 14		FINAL FILTER MERV 16	
		FULL SIZE	HALF SIZE	FULL SIZE	HALF SIZE
		24"X24"x2"	24"x12"x2"	24"x24"x12"	24"x12"x12"
PST3	3000	1	1	1	1
PST4	4000	2	0	2	0
PST5	5000	2	1	2	1
PST6	6000	2	2	2	2
PST8	8000	4	0	4	0
PST10	10000	4	2	4	2
PST12	12000	6	0	6	0
PST15	15000	6	3	6	3
PST18	18000	9	0	9	0
PST20	20000	9	3	9	3
PST24	24000	12	0	12	0
PST28	28000	12	4	12	4
PST32	32000	16	0	16	0
PST36	36000	16	4	16	4
PST40	40000	20	0	20	0

ESP Module

Electrostatic Precipitator

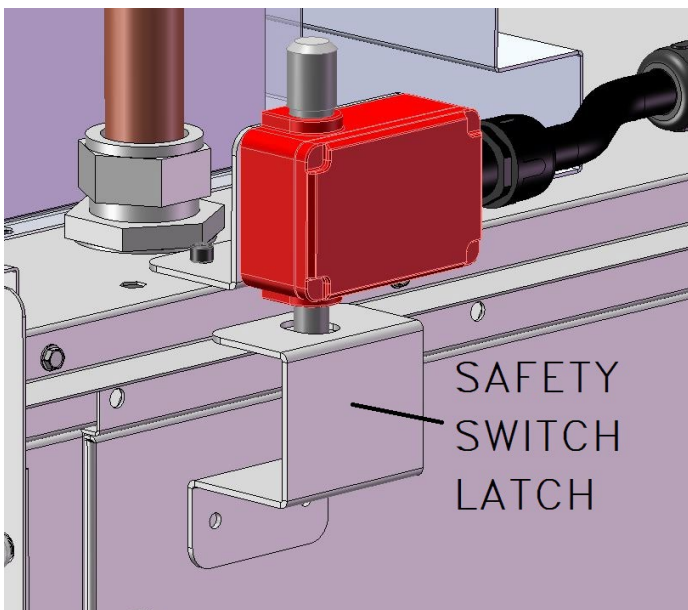
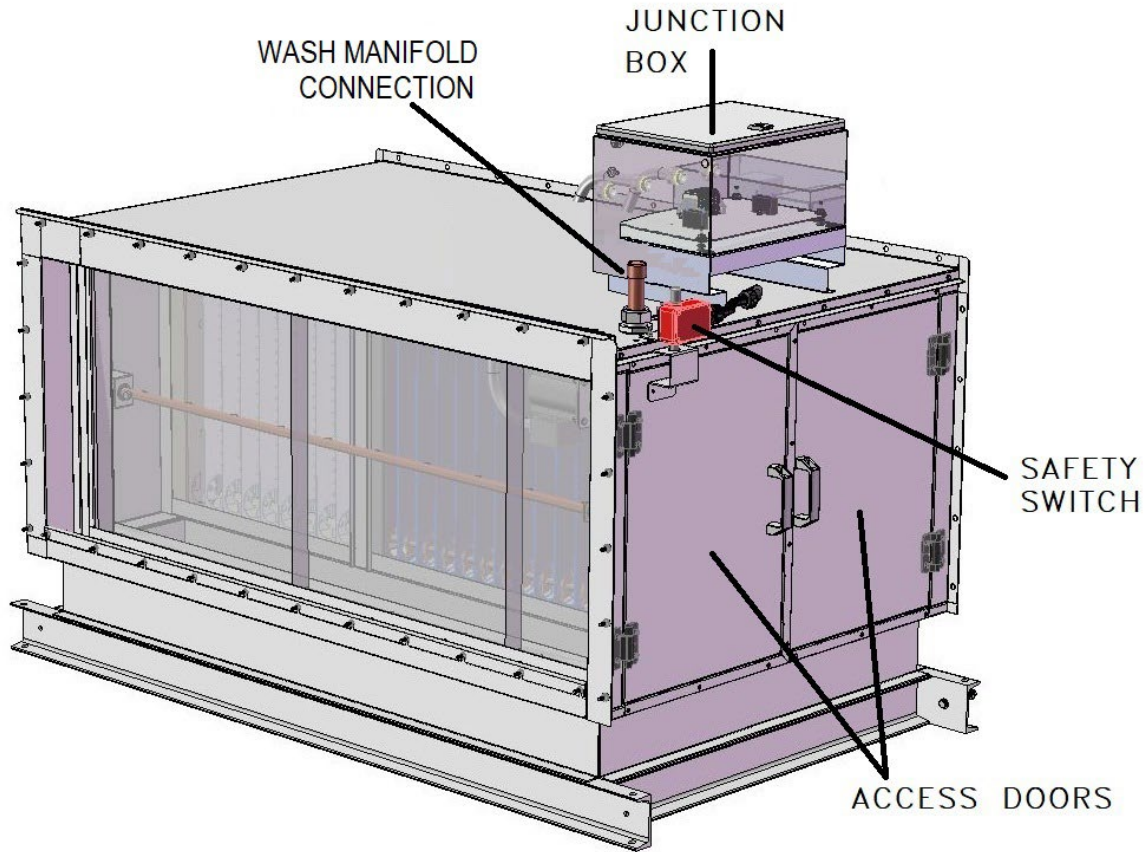

The red safety switch is mounted above the ESP cell access door. The knurled knob must be rotated so that the switch barrel is entirely inserted into the hole in the safety switch latch. Rotate the knurled knob to the end of its travel. Only then will the ESP cells be allowed to energize. To open the access doors rotate the knurled knob so that the switch barrel is withdrawn and the access door can be opened.

System Control, Power Pack: Locate these items in a clean, dry indoor location with adequate room for operator access and as close to each other and as close to the PolluStop unit as possible. Allow adequate room for door swing clearance and servicing. See the attached Field Wiring Diagram and Control System Schematic for details.

Detergent Dispenser: Locate the detergent dispenser in a clean, dry, freeze proof indoor location. This location must be readily accessible as the dispenser requires re-filling periodically. The 3/8" or 1/2" detergent supply line must be tied into the water supply line within 10' of the PolluStop unit. Any detergent or water lines that are exposed to freezing temperatures must be heat traced and insulated. (3000 cfm up to 8,000 cfm units will have 3/8" detergent supply lines, 10,000 cfm to 40,000 cfm units will have 1/2" detergent supply lines. All triple pass units will have 1/2" detergent supply lines.)

High Voltage Cable: High voltage cable is supplied to connect the ionizer and collector sections of the electrostatic cells to the ionizer and collector terminals in the power pack. The red cable is used for the ionizer, and the blue cable is used for the collector. 50 feet of each is furnished unless otherwise specified.

As indicated on the Field Wiring Diagram, the high voltage cables must be installed in separate, metallic conduits, such as EMT or Rigid conduit. Under no circumstances should the high voltage cable be spliced or terminated at locations other than the power packs or electrostatic collectors. If longer lengths of high voltage cable are required for installation, contact Halton.

Knockouts for the conduits that carry the high voltage cables are located on the top and side of the power pack. Use a Greenlee™ type knockout punch to open holes for 1/2" (minimum) conduit. Take caution to keep trash and metal debris away from the Power Packs' interior. The ends of the high voltage cable should not be terminated until the conduit is installed and the cable is pulled. Terminate the cables at the power pack by stripping 3/8" insulation and installing a ring terminal. Securely attached the red cable to the "Ionizer" stud on the power supply, and the blue cable to the "Collector" stud on the power supply. After the connections are made, completely coat the ring terminals with a 1/4" thick layer of silicone caulk. See Figures 1 and 2 for details.

The Control panel controls as follows: Hi voltage power pack, Exhaust fan, MUA fan – (optional), Monitors all filters, Controls all solenoids, Provides schedulers for wash, Monitors fire/emergency situations/ works with the temperature interlocks from hoods.

NOTE: Do not locate this system in an explosive atmosphere.

The electrostatic collectors are factory installed in the PolluStop housing. Figure 3 shows the proper orientation of the collectors.

High Voltage Wiring: See the enclosed Field Wiring Diagram for more details regarding high voltage wiring. Knockouts for the high voltage conduits are also located on the side of the electrical box on top of the unit housing. Route the cable through the conduit and then through the bushings in the bottom of the electrical box into the cabinet. Run sufficient lengths of cable to reach 2" past the upper high voltage spark plug terminals located on the upper electrostatic collector. Terminate the high voltage cables as shown in Figure 4.

Tier-to-tier electrostatic collector connections are made using high voltage jumper cables supplied with the unit. Use the red jumper cables on the ionizing sections of the collectors, and the blue jumper cables on the collecting sections of the collectors. See Figure 5 for details.

To connect the high voltage cables to the collectors, slide the silicone boot over the end of the high voltage spark plug and press firmly until the connection snaps into place.

If the ESP module is chosen the system requires connection to a 1-1/2" or 2" water supply line and a 2-1/2" waste drain pipe. Locate the unit in an area with access to those utilities in a location where electrical connections can be made to the source of the electrical supply without the use of an extension cord. The 18,000 cfm PST is the largest unit with the 1-1/2" water supply line, the 20,000 cfm PST is the smallest unit with the 2" water supply line.

The equipment is supplied with 1-1/4" wash headers located on the top of the cabinet. Connect the wash headers to the wash water supply line as shown on the below Piping Schematic. Where applicable, provisions must be made by the installer to protect all water supply and drain lines from freezing, using trace heat and thermal insulation.

PLUMBING NOTES:

- 1) Piping shown with broken lines (- - -) to be furnished and field installed by the contractor.
- 2) All components shown, except the Detergent Dispenser and Wash Manifolds, are provided by others, for field installation by the contractor. Components may be ordered from the Halton Factory by the Part numbers shown below. A Plumbing Package with all required components except piping may be purchased from Halton. Order part number 60282 and specify pipe size (1-1/2" or 2") and voltage (120V for North America or 230V for International).
- 3) Trapped drain line water column to be sized for total system static pressure loss plus an additional 1.0" w.g. (see illustration below). Drain shall be plumbed to an approved grease interceptor.
- 4) Water supply and drain piping exposed to freezing must be trace heated and insulated.
 1. Note: Detergent dispenser, system control and power pack must be located indoors, protected from the elements and freezing temperatures. These 3 items should be located in a common area.
 - Mount the detergent dispenser.
 - Connect wash water supply line, detergent line and shown plumbing components.
 - Connect 2-1/2" NPT drain/P-trap.
 - Fill trap with water.

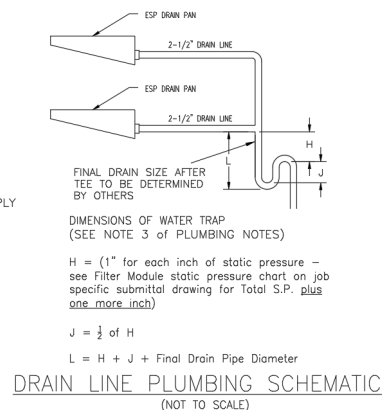
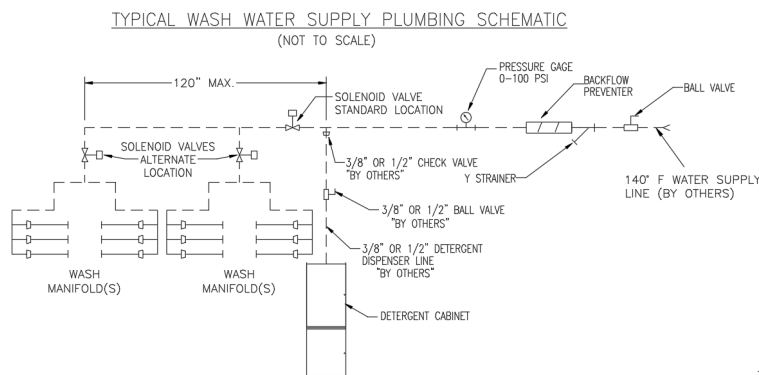

1 1/2" PLUMBING KIT	
COMPONENTS	PART #
BALL VALVE 1 1/2"	11883
BACKFLOW PREVENTER 1 1/2"	11995
"Y" STRAINER 1 1/2"	12040
SOLENOID VALVE 1-1/2" 120V	12036
SOLENOID VALVE 1-1/2" 230V	11969
BALL VALVE 3/8"	12627
PRESSURE GAUGE	11991
CHECK VALVE 3/8"	12579

2" PLUMBING KIT	
COMPONENTS	PART #
BALL VALVE 2"	11886
BACKFLOW PREVENTER 2"	12038
"Y" STRAINER 2"	12039
SOLENOID VALVE 2" 120V	12037
SOLENOID VALVE 2" 230V	12409
BALL VALVE 1/2"	11887
PRESSURE GAUGE	11991
CHECK VALVE 1/2"	11894

Double Pass Esp Systems Sized For 15,000 cfm And Above Require Two Solenoid Valves. Triple Pass Esp Systems Sized For 10,000 cfm And Above Require Three Solenoid Valves

Detergent Concentrate Cabinet Set Up

Use the following procedure to adjust the concentrate delivery system to provide the correct amount of detergent for the unit being installed.

1. Fill an empty 5 gallon container with a few gallons of water. Place the detergent siphon so the intake tube is in the water.
2. Determine the gallons per wash from the chart below, select the inches per wash from the column to the right of the gpm. Wash should run for 4 minutes so multiply inch/min by 4.
3. Mark the present water level of the test container (on outside of container) and the appropriate ending level (anticipated water level after wash) dimension down from the top of the water.
4. Run the wash and measure the difference in height.
5. Adjust the bypass valve +/- to correct the flow rate.
6. Repeat until you achieve the correct height change.
7. Lock the bypass valve. (valve has an allen screw lock on the barrel of adjustment cap)
8. Place the detergent concentrate container in the cabinet and the siphon in the container.

Concentrate System			
Unit Size (CFM)	Detergent Consumption		
	Gallons	GPM	inches / min
3000	0.12	0.12	0.29
4000	0.16	0.16	0.39
5000	0.19	0.19	0.47
6000	0.23	0.23	0.56
8000	0.31	0.31	0.76
10000	0.39	0.39	0.96
12000	0.46	0.46	1.13
15000	0.58	0.58	1.42
18000	0.69	0.69	1.69
20000	0.81	0.81	1.98
24000	0.92	0.92	2.25
28000	1.04	1.04	2.55
32000	1.23	1.23	3.01
36000	1.38	1.38	3.38
40000	1.54	1.54	3.77



Use a 1/16" allen wrench to lock the bypass valve after adjustment is complete

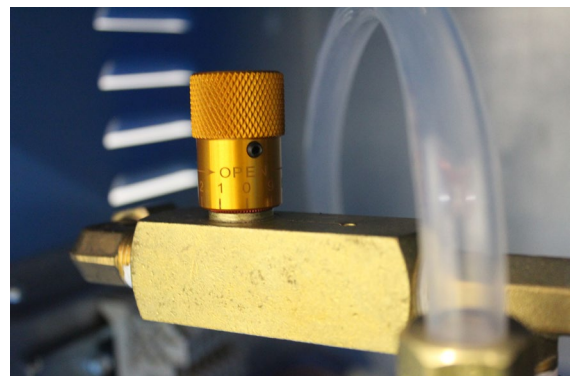



Primary Wiring:

WARNING - RISK OF ELECTRIC SHOCK - These instructions are for qualified personnel only. To reduce the risk of electric shock, do not perform any servicing other than that contained in the instructions unless you are qualified to do so.

All wiring should be installed according to national, state and local codes.

All wiring should be permanently installed in conduit. Under no circumstances should extension cords be used to connect the source of the electrical supply to the equipment.

The System Control, Power Pack and PolluStop housing must be grounded to structural steel/earth ground. The motor on the detergent feeder, and the solenoid valve must be properly grounded.

Refer to the Interconnecting Wiring Diagram for the electrical connections.

High Voltage Power Supply (HVPS or Power Pack)

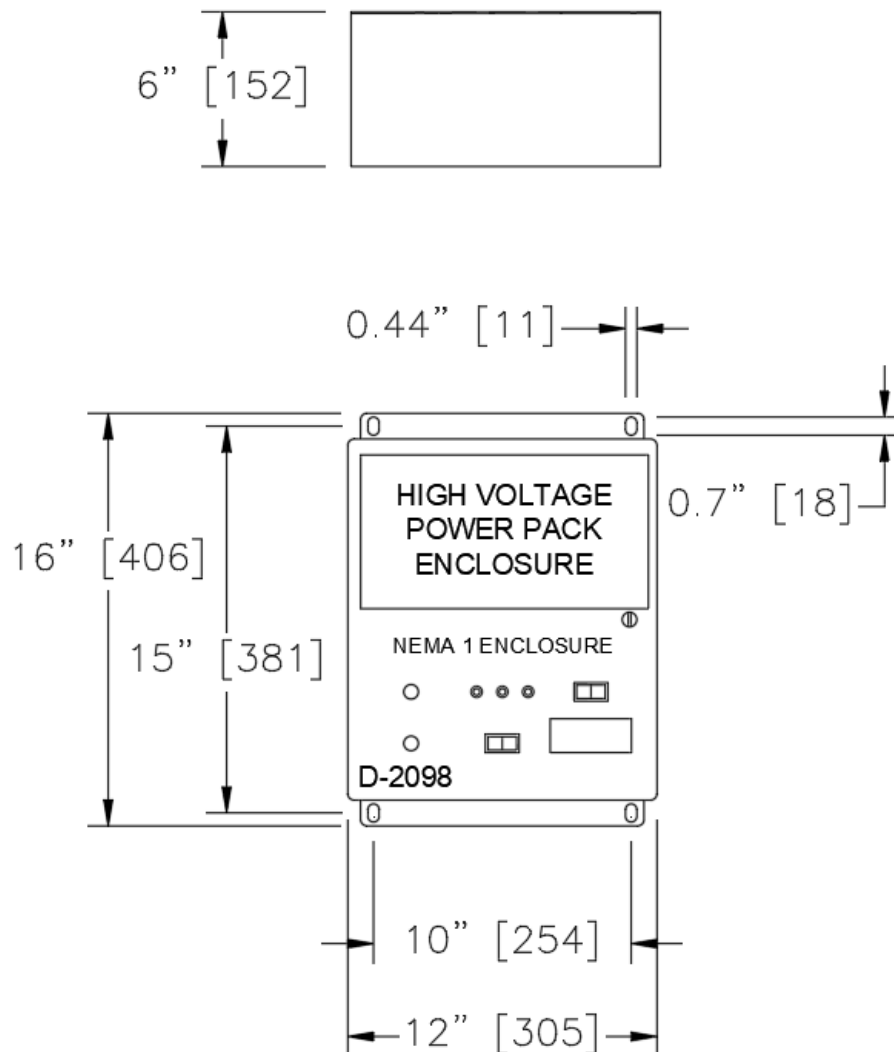

Table below presents the number of power supplies to use when using one, two or three passes of ESP cells.

PolluStop High Voltage Power Supply (HVPS) All Appliance Duty Levels							
PST Size	Enclosure Size (H x L)	QTY of Cells (Per Pass) (LxH)			Amp Draw	HVPS Per Pass 30	Clean Load per Pack (mA)
		2x2	2x1	1x2			
3	16" x 12"	1	0	1	5	1	5
4		2	0	0	6	1	6
5		2	0	1	8	1	8
6		2	2	0	10	1	10
8		4	0	0	12	1	12
10		4	0	2	16	1	16
12		6	0	0	18	1	18
15		6	3	0	24	1	24
18		9	0	0	32.4	2	16.2
20		9	0	3	33	2	16.5
24		12	0	0	36	2	18
28		12	4	0	44	2	22
32		16	0	0	48	2	24
36		16	0	4	56	2	28
40		20	0	0	60	2	30

Halton PolluStop HVPS and Wash System Replacement Part Numbers

Halton Part No.	Part Description
11848	ESP POWER SUPPLY 120V
12583	3/8" detergent pump
11953	1/2" detergent pump

Initial Start-Up of ESP Module

1. Switch the disconnect on the VFD cabinet to OFF position
2. Turn OFF the power pack (located on the top of the filter section)
3. Power up the marvel control panel. System control automatically starts according to MARVEL operation. On the HMI located on control panel go to PolluStop (PST) screen. Please confirm if the “normal operation” indicator light is lit green.
4. Simulate operation of the system by pressing override button on any hood.
5. Turn on Power Pack, red and clear lights should be on at Power Pack and at System Control. If lights are not on check to make sure door interlock switch is made. With high voltage on check meter reading at Power Pack, should read 12kv and approximately 6 mA. Random electrical arcing in the collector cells is normal, at initial power up. This will settle down.
6. Switch the disconnect on the VFD cabinet to ON position. Fan should start running.
7. System should now be in normal run mode. Green light indicator on HMI indicates normal run mode
8. Turn off Marvel control panel. System control, power pack and fan should be off.
9. Turn back on the control panel and simulate the operation of one of the hoods, system should be up and running and “normal operation” green light indicator should be ON.
10. To check the wash operation: When fan is not running go to the HMI screen and press “initiate wash” button or set up the scheduler for wash test. Indicator light “wash in process” should be on,. All other indicator lights should be off. Please see manual for wash sequence. Please note that there is a 5 min. delay prior to wash cycle starting. Check all piping for leaks. Monitor the operation on the HMI screen looking on wash status screen.
11. Open all water line manual ball valves. Ensure there is detergent in the detergent dispenser (water is used to initially calibrate the dispenser). Initiate the wash mode by depressing the manual wash button, wash in process light should be on. All other lights should be off. See manual for wash sequence. There is a 5 min. fan coast down time prior to wash cycle starting. Check all piping for leaks.

Coarse fin ESP Cells Part Numbers

Halton Part No.	Part Description
60437	Coarse Collector Cell: (Front 2H X 2W)
60474	Coarse Collector Cell: (Intermediate 2H X 2W)
60475	Coarse Collector Cell: (Rear 2H X 2W)

Fig. 1 High Voltage Cable Terminations

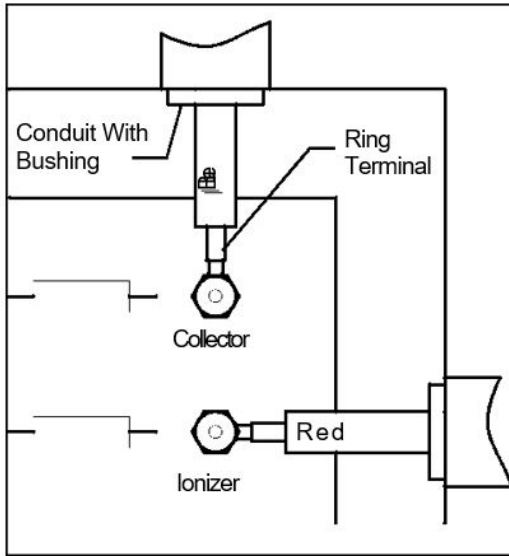

Fig. 2 High Voltage Termination Insulation

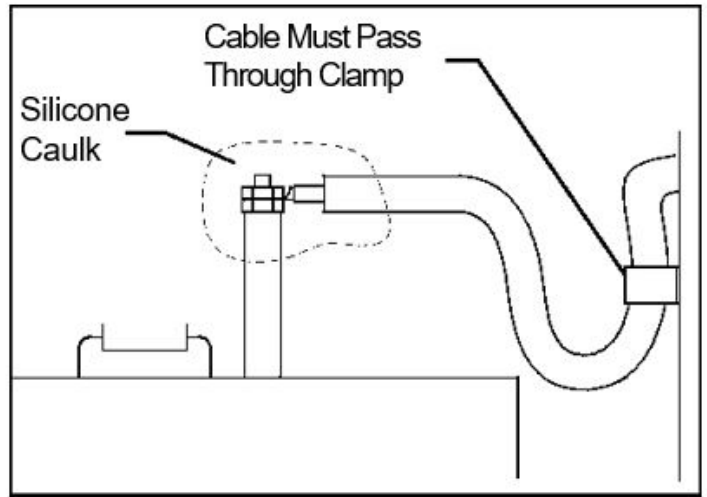

Fig. 3 Electrostatic Collector

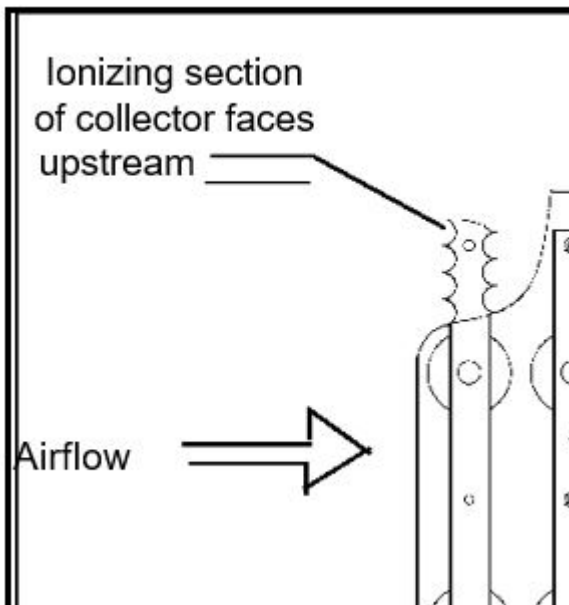
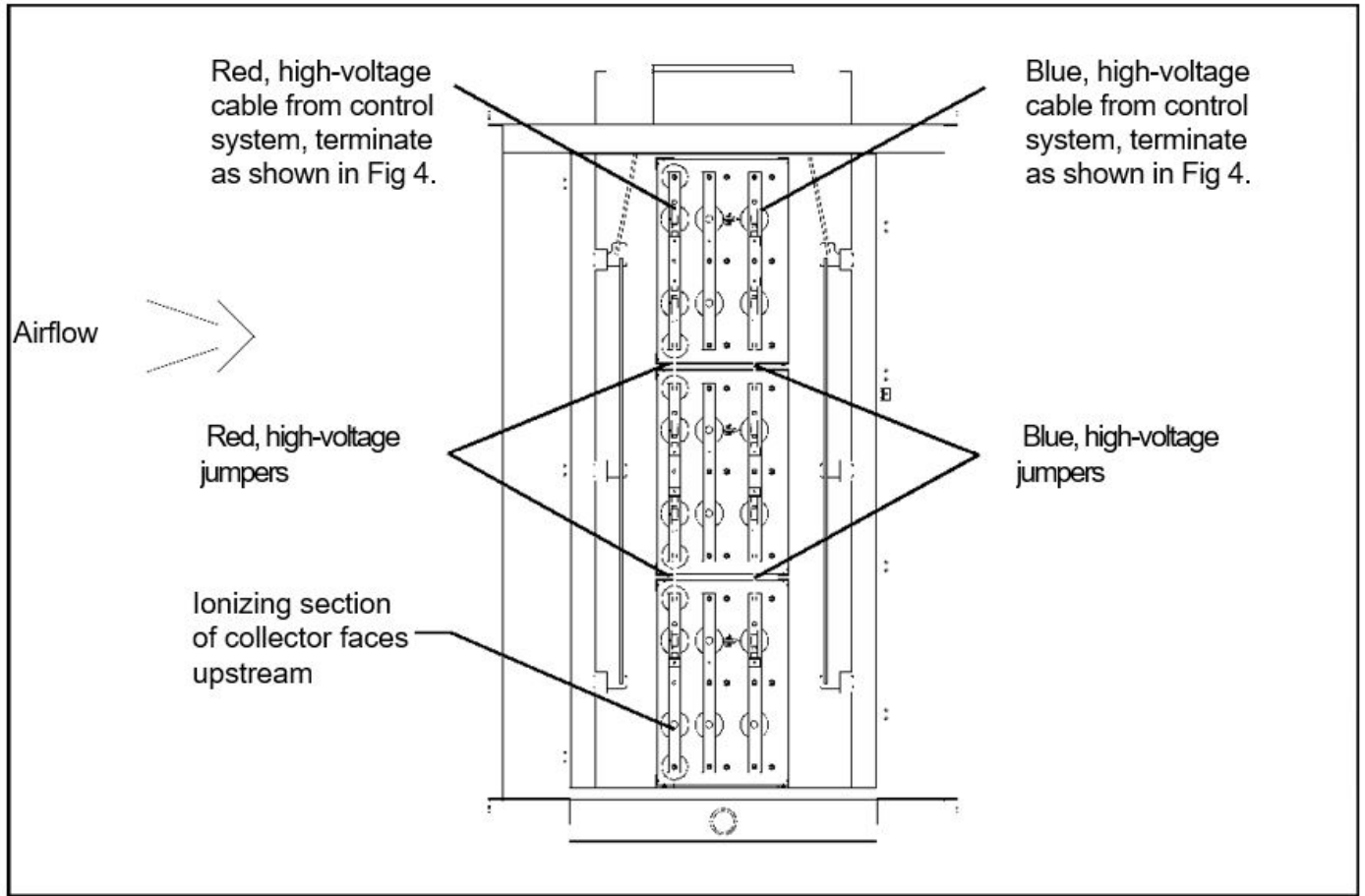

Fig. 4 High Voltage Cable Terminations

- Slide silicone boot over cable
- Strip 3/4" insulation from cable
- Fold wire down and back
- Lay wire in terminal and crimp tightly
- Slide boot over terminal

Fig. 5 High Voltage Connections



UV/Carbon Module

UV with 2" Carbon Panels

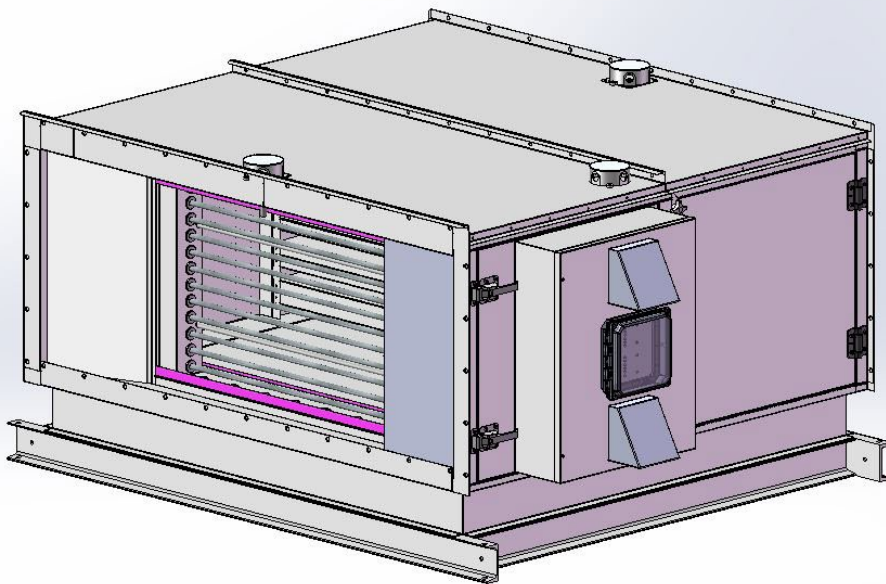

UV/Carbon Module Overview

The UltraViolet (UV) light combined with Carbon Panels module is a strategy for reducing and removing the Volatile Organic Compounds (VOC's) in the exhaust air before returning the exhaust air to the environment. The UV contributes to a process called photocatalytic oxidation that greatly reduces VOC's from the exhaust. The Carbon Panels use a process called adsorption to attract and capture most of the remaining VOC's.

The UV/Carbon module section is typically used in Odor Critical situations for maximum mitigation of perceived odors in the kitchen hood exhaust airflow. Ultra Violet (UV) light is used together with carbon panels to achieve this reduction in perceived odors. In addition, the Pollustop UV/Carbon module is equipped with the Pollustop Nose, a first of its kind sensor that measures VOC's at the inlet of the module and at the outlet of the module and can provide a report of VOC reduction data and also monitor Carbon Panel life.

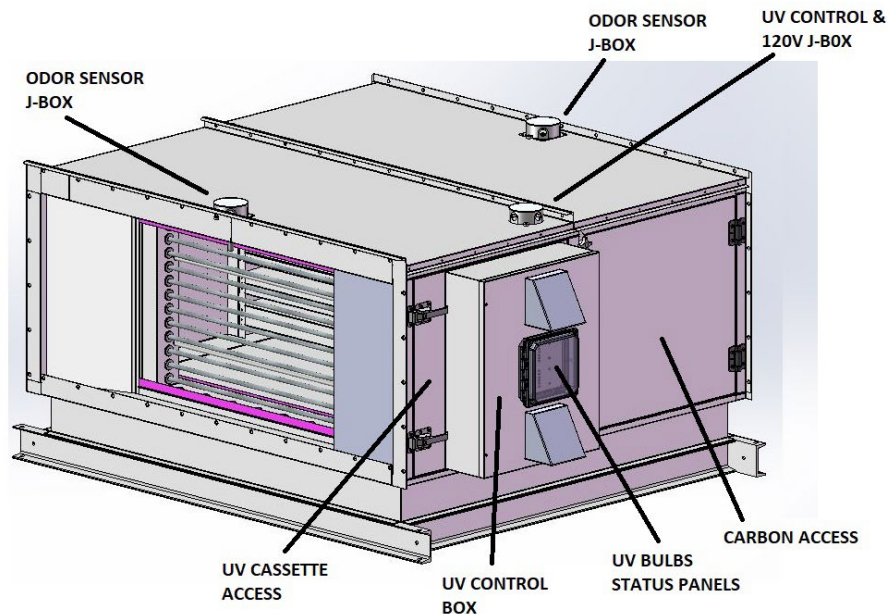

Carbon panels are shipped separately – don't open packaging until the exhaust system is ready for test and balance.

Remove packaging and install the number of panels required for your unit. See project submittal drawing for quantity and type (size) of carbon panels for your unit.



Replacement Parts	Part No.
UV Bulb 38" Cassette	60131
UV Bulb 66" Cassette	60132
UV Ballast	10847 (120V) 10846 (240V)
Nose Odor Sensor	10486
Nose Odor Sensor Cap	12238
Odor Sensor Circuit Board	12234
UV Bulb Status Panel	11039

UV Bulb Status Indicator Panel

UV bulb status indicator panels are located on the front of each UV control box door. There will be two status panels (total of 12 LED's) for each cassette the module has. The LED indicator lights show that the corresponding UV bulb for that cassette is operating normally. If a bulb burns out or stops working the corresponding LED indicator light will go out also.

Carbon Panels

Activated Carbon Panels - The UV/Carbon module uses 24" x 12" x 2" and 24" x 24" x 2" Carbon panels. Carbon panel replacement frequency is dependent on the volume of and duty level (Light, Medium, Heavy or Extra Heavy Duty) of cooking. Replace when an increase in odor breakthrough is first noticed. Change out may occur between 3 to 6 months. This is only a guide and the frequency may be less or greater dependent on the cooking operation. Solid fuel applications will require more frequent changes. For replacement Carbon Panels please call the Halton Service Network at 270-237-5600 or 800-442-5866.

Replacement Carbon Panels	Part No.
Carbon Panel 24" x 12" x 2"	11858
Carbon Panel 24" x 24" x 2"	11857

Module Installation

Connect each module of the PolluStop system to the next consecutive module per Job Specific Submittal drawings for this location. Make the mechanical connections per the instructions on page 44 of this manual.

Electrical Connections

Field wiring connections must be made. A three wire 120 volt power connection for the UV cassettes, a 5 wire low voltage connection for the UV control and a 4 wire low voltage connection for each "Nose" must be connected from the UV/Carbon module to the Pollustop Control Panel. Electrical junction boxes are provided on top of the module to make these connections. There is a "Nose" sensor in the airstream before the UV cassettes and another "Nose" sensor after the last Carbon Panel section. If the unit has double pass Carbon Sections, that is two Carbon Sections in a row, then the second "Nose" will be after the second Carbon section. There will be only two "Nose" sensors per assembly. There will not be a "Nose" sensor between two Carbon Panel sections. Please see the connection diagram below.



Picture of Nose Odor Sensor

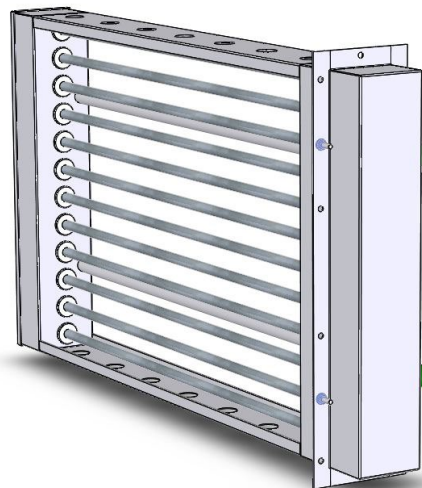

UV Cassette

120 Volt and UV Control Wiring

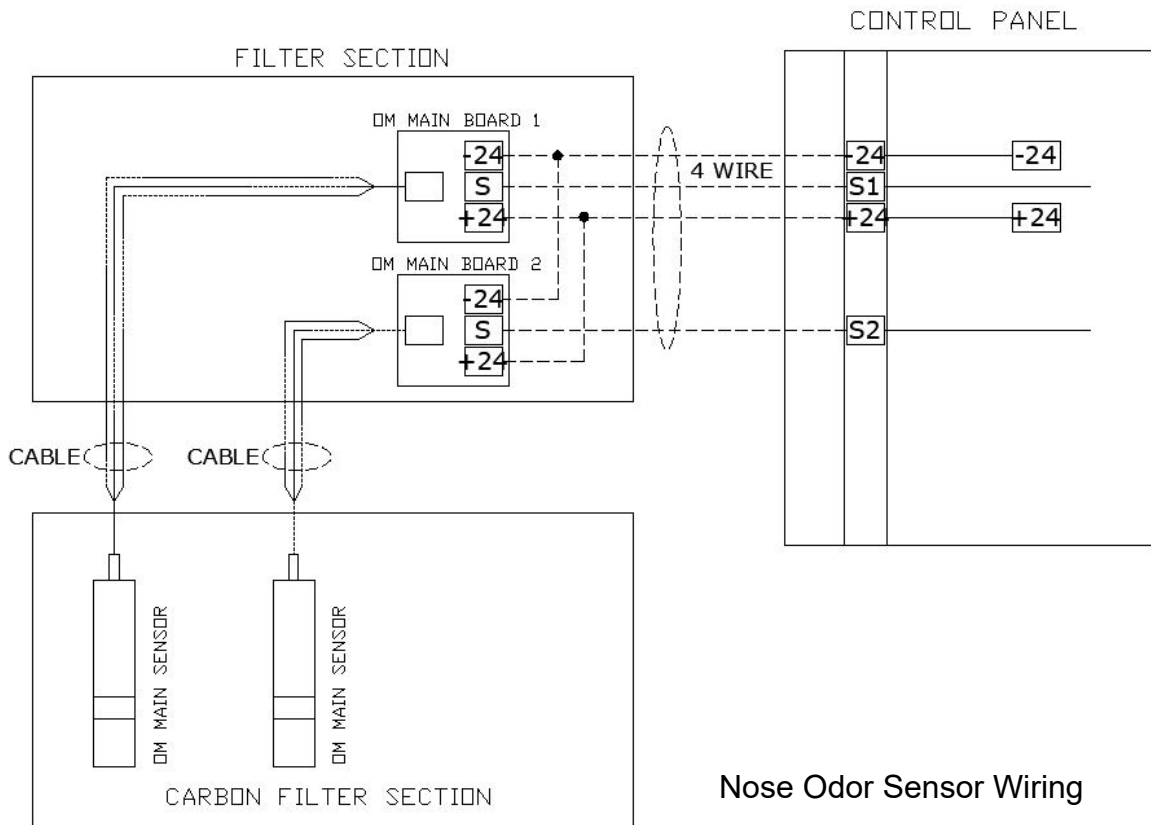
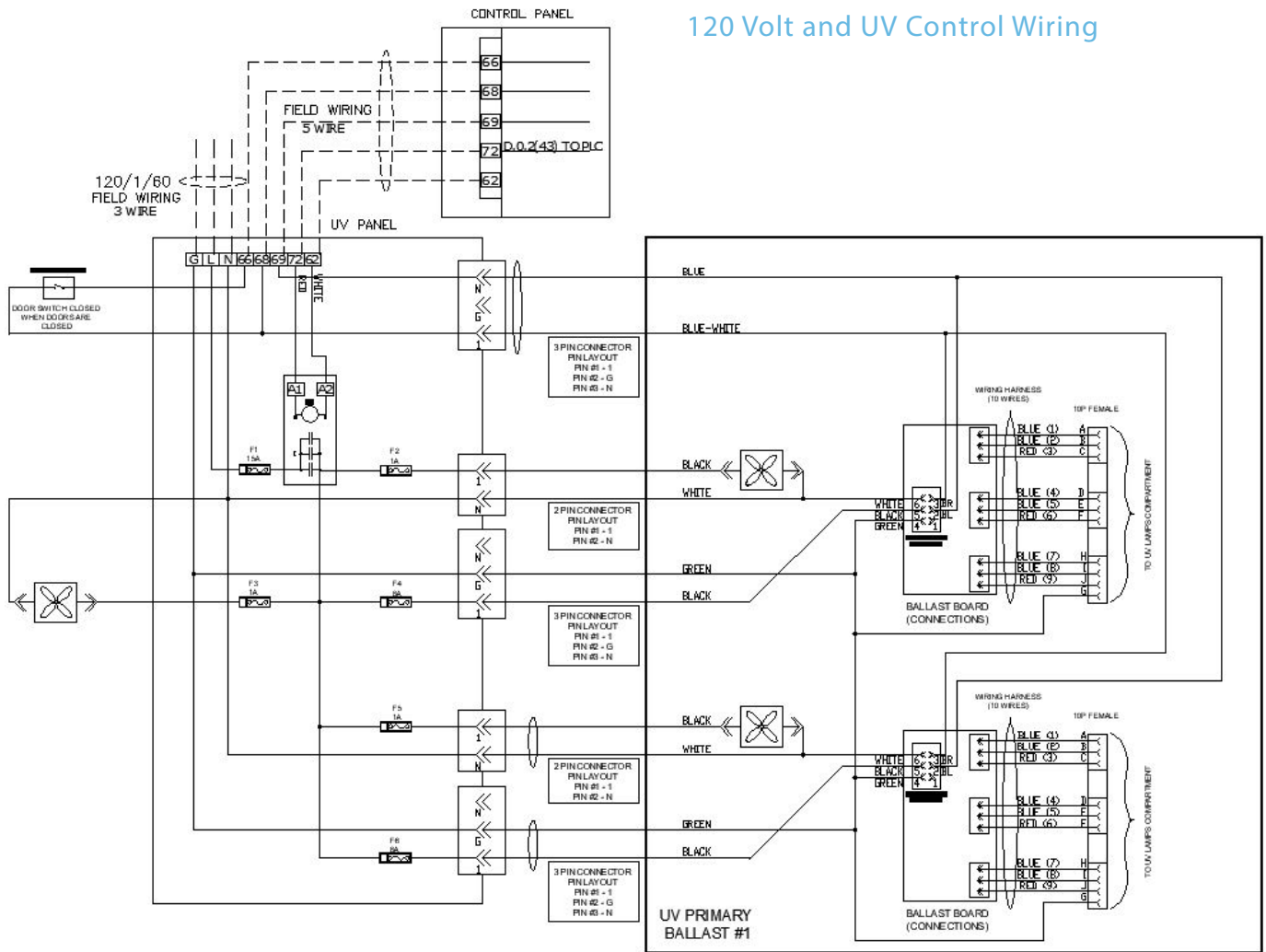

Nose Odor Sensor Wiring

Odor Sensor Reporting

Please see the description of the touch screen in the Control Panel section of this manual, starting on page 39. The following additional displays will be depicted on the touch screen when the UV/Carbon module is incorporated into the Pollustop unit's features. The touch screen on the control panel will report the Carbon Filter Life with a symbol shown below. The color of the symbol will change from green to yellow to show the Carbon Panels are approaching the end of their useful life. The color will change to red when it is time to change the Carbon Panels. Please call the Halton Service Network at 270-237-5600 or 800-442-5866 for replacements, or email parts.us@halton.com.



In addition, for odor critical applications-typically where the UV/Carbon module is followed by an additional Carbon Panel module, there will be a Carbon Panel Efficiency display near the Carbon Panel status symbol. This efficiency display will be a decimal number. The maximum efficiency is one (1.000). See below illustration.



- Internal ultraviolet radiation source present.
- Keep protective barrier in place.
- Replace all removable parts after servicing.
- An interlock is in place to reduce the potential of exposure to excessive ultraviolet radiation. DO NOT attempt defeat or bypass this interlock system.

ULTRA VIOLET (UV) OPERATIONS WITH UV MODULE SEQUENCE OF OPERATION

- If UV access door opens the UV lamps turn off.

POLLUSTOP WITH UV

UV turns off based on pressure discrepancy. UV will be turned off if fan is running under the following conditions:

- If filter is missing in PST, UV will be turned off if fan is running
- If filter door, ESP door, Carbon door, or any door is opened while fan is running, UV will be turned off based on internal pressure drop

ODOR

Scentry™ Odor Control

PolluStop Odor Control

(The PolluStop Odor Reducing Module is optional)

To prepare a 5 gallon/22 liter bottle of odor solution ("Scentry") for use.

1. Open enclosure cabinet door using the special key. See Figure 5. (The key ships attached to the door with a zip tie.) See Figure 6.
2. Screw the cap off the bottle/reservoir.
3. Place the low level probe in bottle on the neck of the bottle, taking the place of the cap. See Figure 7.
4. Cut a hole in the bottle for the dip tube. There is an indentation in the top of the bottle next to the handle and opposite the neck where the level probe is. This is the location to cut the hole for the dip tube. There may be a nipple in this location which may be cut off to allow the dip tube to be placed in the bottle. See Figure 8.
5. Put the dip tube assembly into the bottle. Make sure the dip tube reaches the bottom of the bottle.
6. The switch to turn on the compressor must be placed in the "On" position.
7. Close the cabinet door and lock with the key.



Figure 5

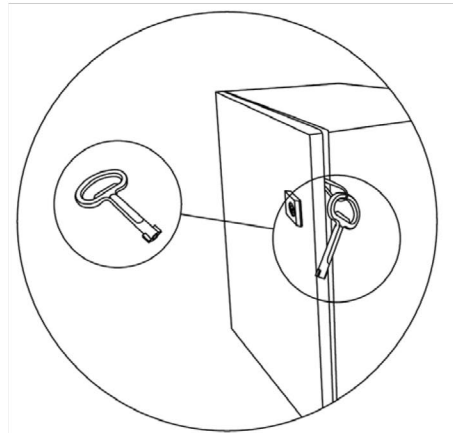

Figure 6

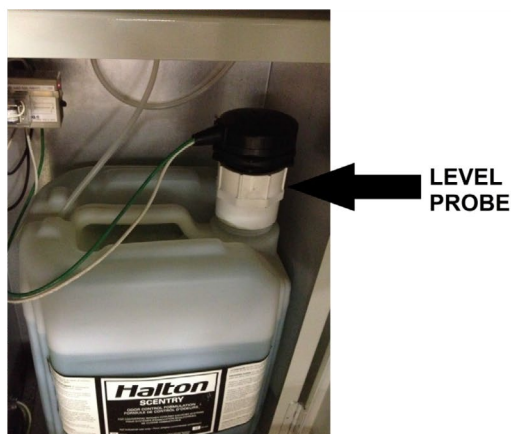

Figure 7

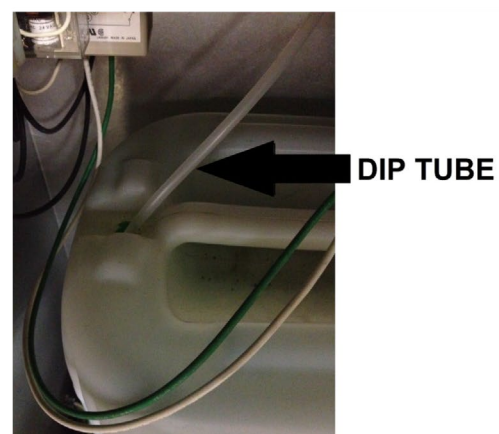

Figure 8

HRU MODULE

Heat Recovery Unit

Heat Recovery (HRU) Module Illustration

The HRU uses air to water heat transfer to obtain usable heat reclaim for a variety of user specified uses. The HRU has copper tubing containing circulating water to effect a temperature rise in the water from the heat of the exhaust air passing through the PST unit.

Fluid flow through the unit and temperature rise are job specific. See job submittal drawings for details.

The size of the HRU module will depending on the cfm of the PST unit and the requirements of the job. The engineer of record must specify the size, and how it is used, for example to pre-heat water or temper makeup air. The coil can be inspected and serviced from its access door for cleaning if needed. The coil can be removed from the unit's housing by unbolting the plate and slide out the coil. Larger units will have multiple stacked coils in the compartment.

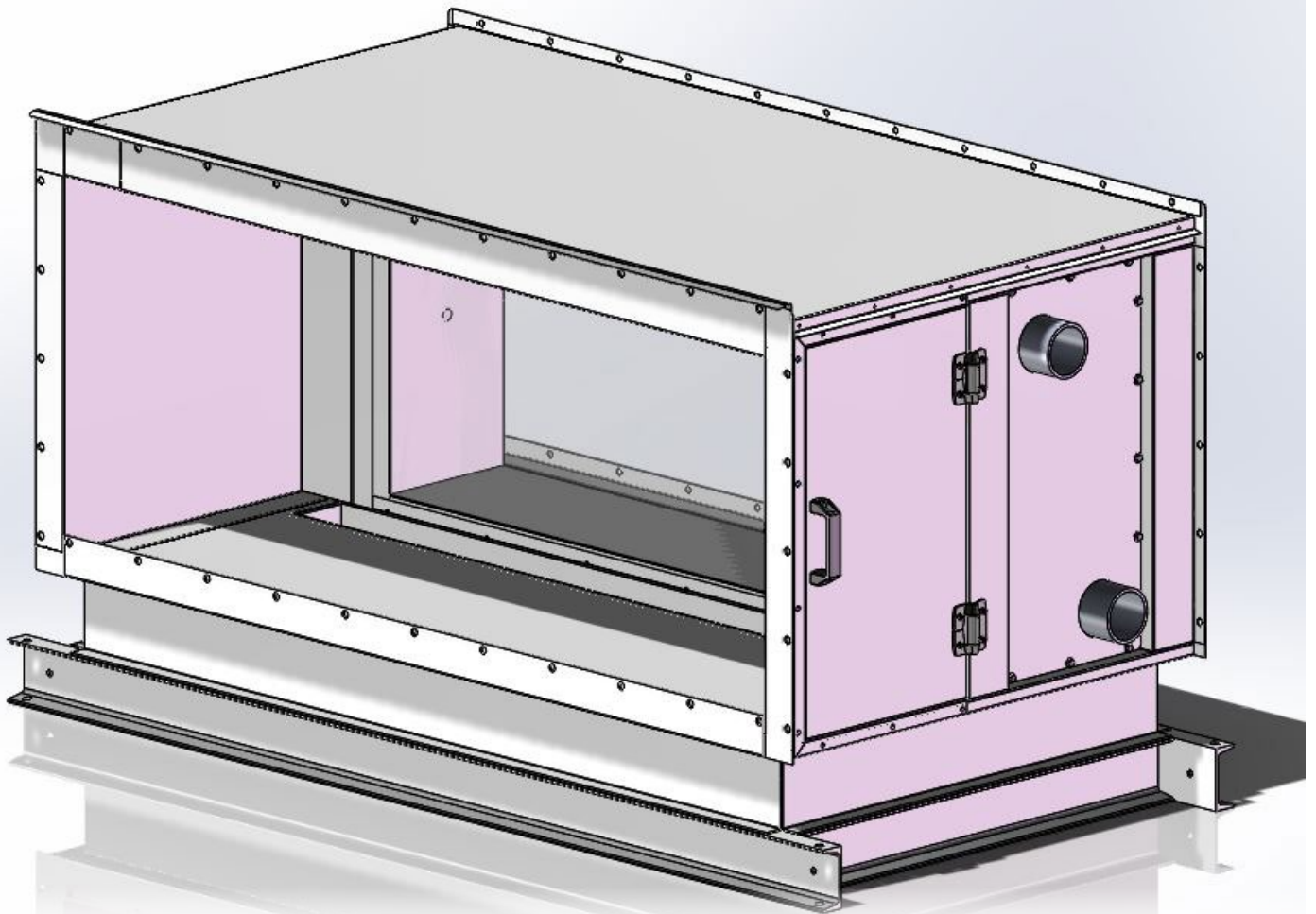

FAN MODULE

Fan Section

Important note:

Before starting the fan unit, remove fan isolator hold down brackets. The brackets are used for shipping purposes only. When the brackets are removed, the fan should float freely on the spring isolators. Units of 6000 cfm capacity and below have four spring isolators; units above 6000 cfm capacity have six spring isolators. See Figure 9.

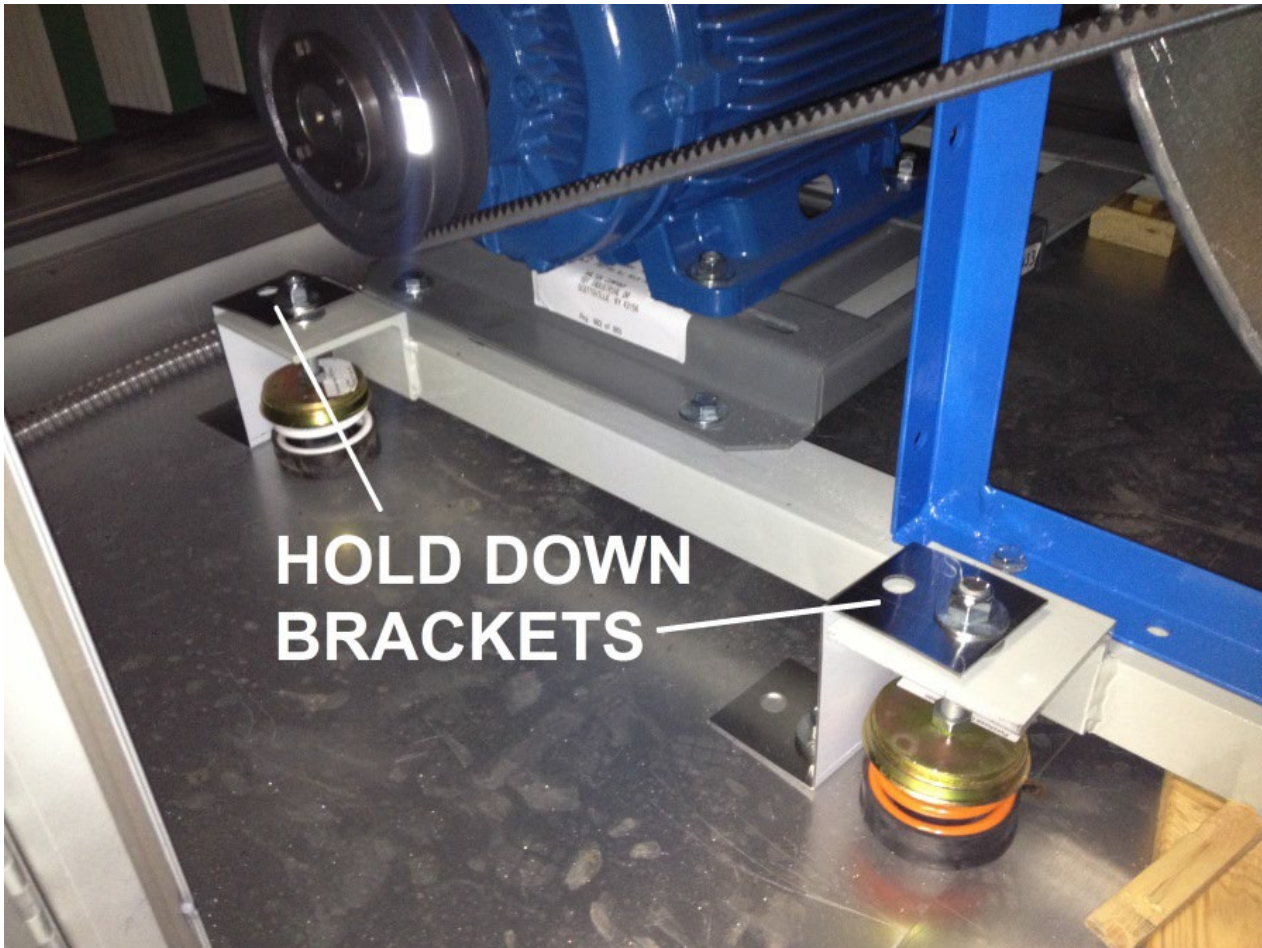
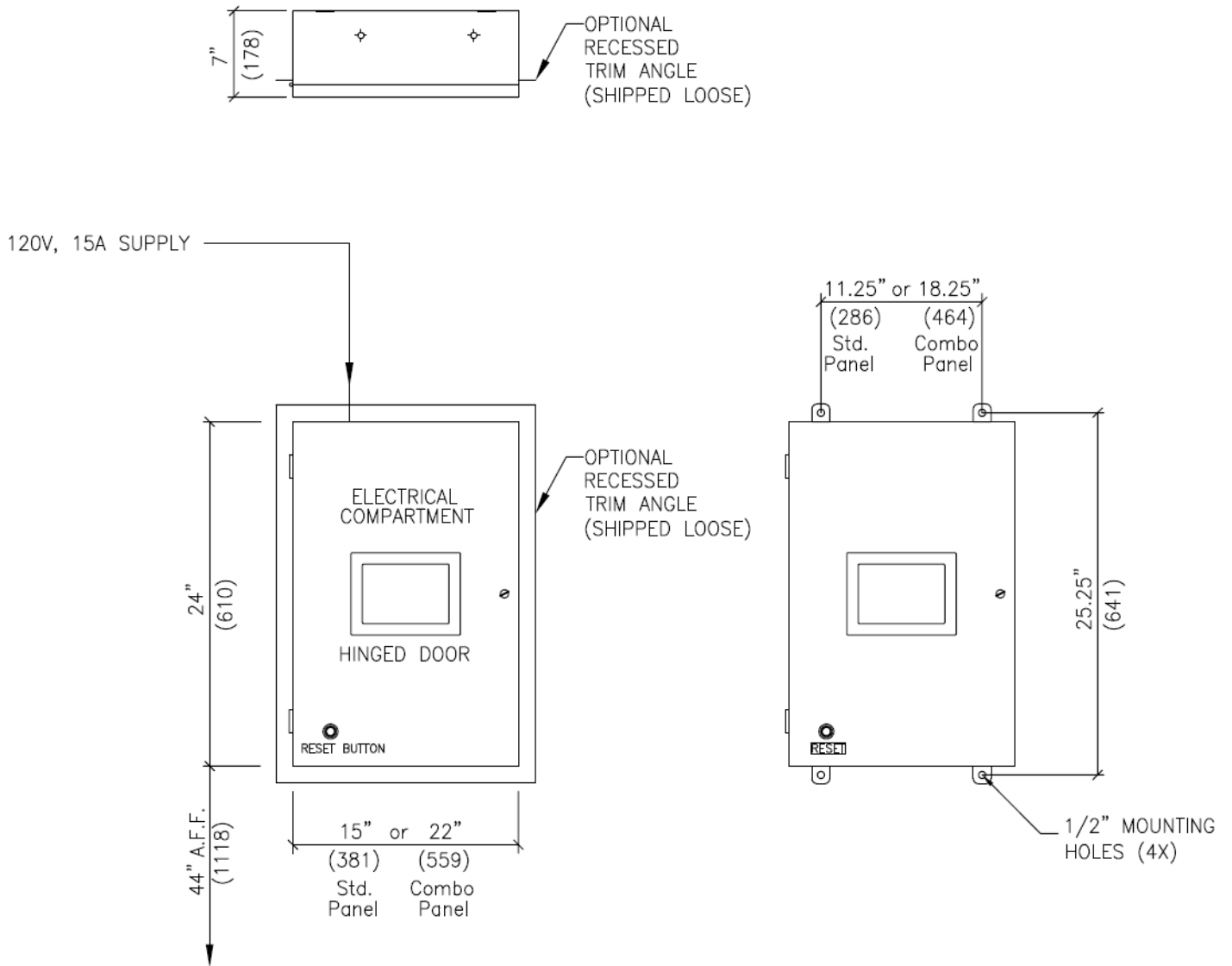

FIGURE 9

CONTROL PANEL

PolluStop Control Panel



The Control Panel has a provision to satisfy the Canadian requirement for cooking appliance interlock with the PolluStop unit. In accordance to Canadian UL Standard S647, each filter component (grease and odor) shall have an interlock to prove the component is in place. Where any of these interlocks are interrupted, the cooking equipment shall not be able to operate and the fans (exhaust and re-circulation) shall be disabled. This interlock circuit is found on the job specific wiring diagrams included with the submittal drawing set.

Control Panel Features

Features:

- Service connection to 120/1/60 Hz.
- Microprocessor based.
- User friendly touch screen for easy monitoring of parameters in the system.
- One control panel per system controls exhaust and MUA fan.
- Remote system status monitoring (Internet remote connection as an option).
- Setting of the hood airflows (calibration) through touch panel.
- Monitors each filter condition and maintains constant airflow in the system regardless of the filter condition.
- Setting of odor control unit operation through the touch panel.
- Monitors system and displays text messages for all alarms in the system.
- Size 15" x 24" x 7".

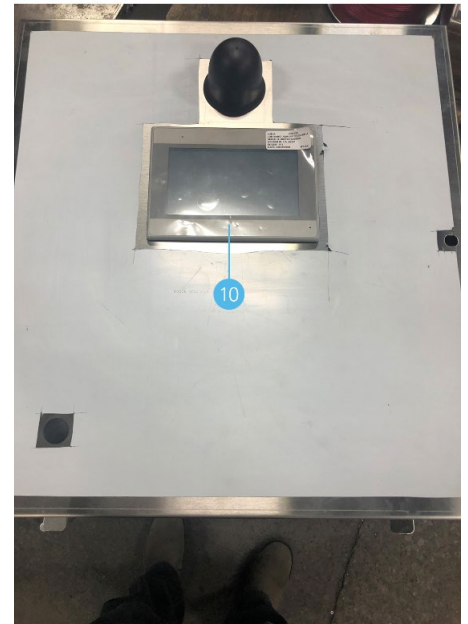

Main Components of the Control Panel

1. Enclosure Panel
2. Control Transformer
3. Edge Device
4. Communication 5 port switch
5. Power Supply 24 VDC
6. Power supply 5 VDC
7. Fuse Holder (Midget Type)
8. Terminal Block Ground
9. PLC Controller
10. HMI (Human Machine Interface) - Touch Screen
11. Control Relay
12. Wire Duct
13. Terminal Block Distribution
14. Fuse Holder (Glass Type)
15. HMI Connection Cable
16. Glass Fuse
17. Fuse (Time Delay)

PolluStop Control Panel

Home Screen

The central control panel features a user friendly touch screen interface. The following illustrations depict the navigation and features of the touch screen.

Note: Touch screen samples shown below are for the basic PolluStop system.

This touch screen allows the user to scroll the screen up and down to view the entirety of the home page or any of the pages. Certain selections have pull down menus to access different features of the selection.

Below illustration shows the main features of the home screen, which can be accessed from any subsequent screen by pressing the "Home" icon at the bottom center of the screen.

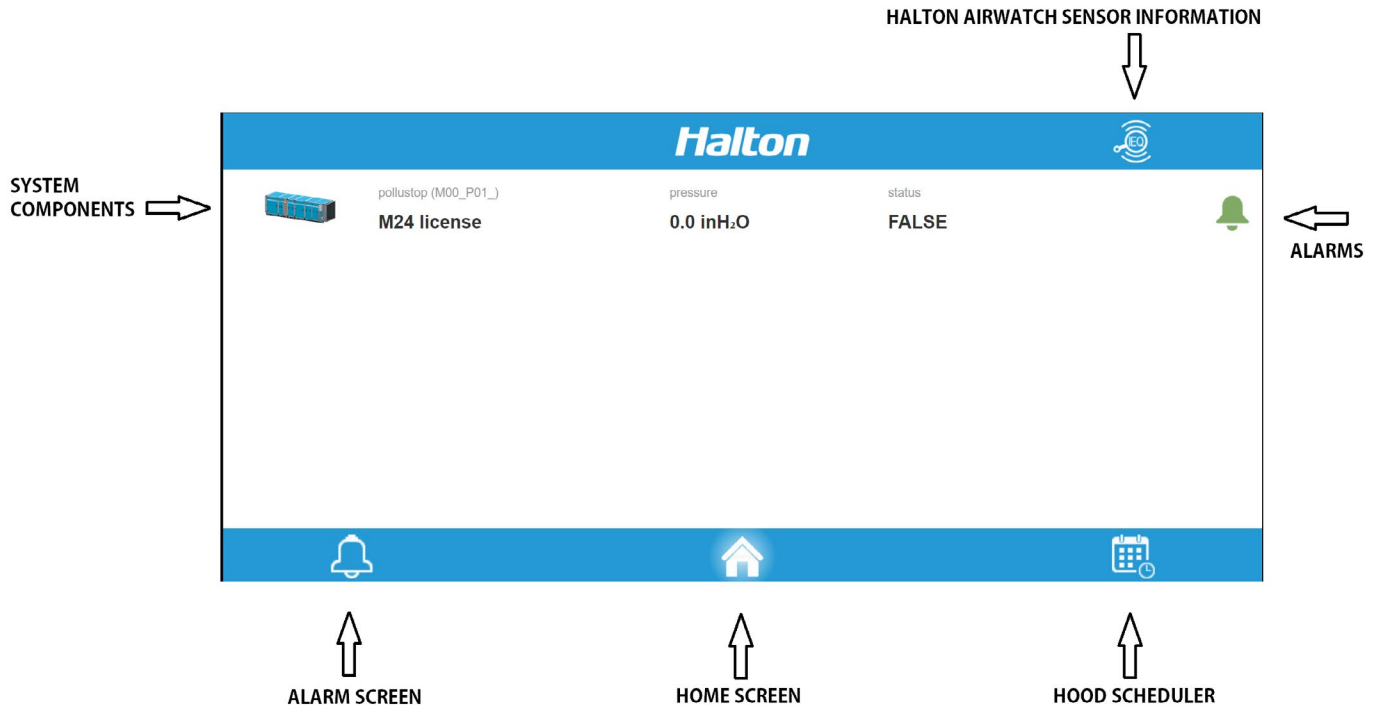

Individual Unit Selection Screen

Select one of the System Components on the Home screen to view the details about this item. This screen will allow you to drill down into the operation of the selected unit. Once selected you may scroll down for additional information about the unit (next two screen illustrations, below).

The screenshot shows the top portion of the Halton M24 license screen. The header includes the Halton logo, a wireless signal icon, and a power button icon. Below the header, there is a notification bell icon, a license icon, and the text "pollustop M24 license". The main content area displays a table with three columns: "name", "value", and "status". The visible rows are:

name	value	status
FAN_CA_ExhStartStop_ST	FALSE	●
Exhaust Fan VFD Speed	0.0%	●
ELF filter status	Clean	●
ELF filter remaining life	100.0%	●

The bottom navigation bar contains a notification bell icon, a home icon, and a calendar icon.

Scrolling down will reveal more of the screen.

The screenshot shows the bottom portion of the Halton M24 license screen. The header and top navigation elements are the same as in the previous screenshot. The main content area displays a table with three columns: "name", "value", and "status". The visible rows are:

name	value	status
ELF filter status	Clean	●
ELF filter remaining life	100.0%	●
GEN_CA_MainDuctDiffPress_MR	0.0 inH ₂ O	●
ODR SCP remaining life	0.0%	●

The bottom navigation bar contains a notification bell icon, a home icon, and a calendar icon.

PST Auto Scheduler Screen

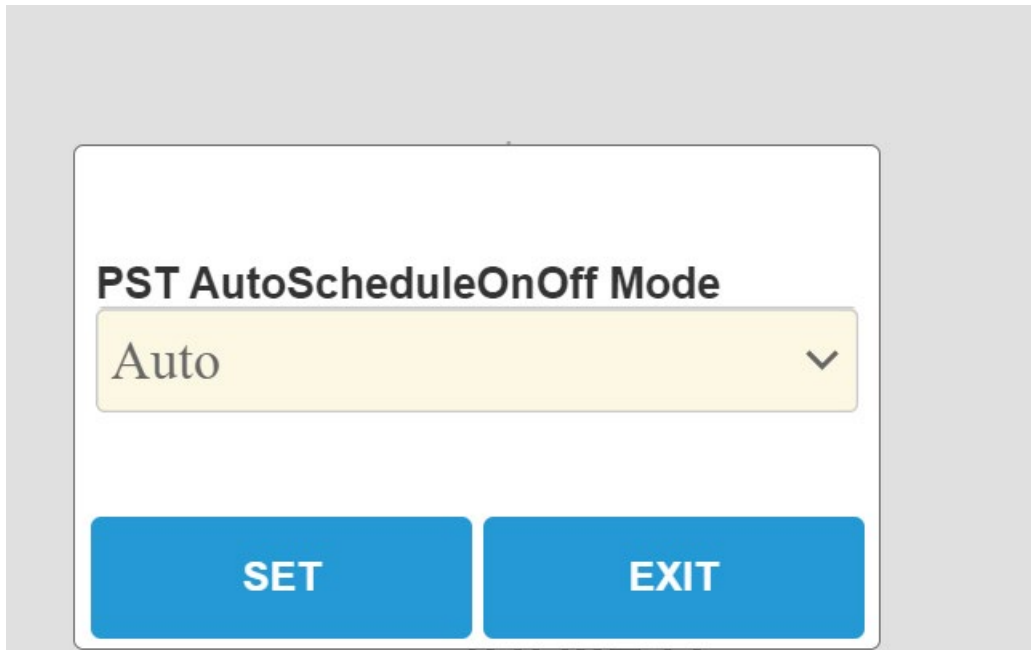

Pressing the purple button in the top right corner of the Individual Unit Selection Screen will access the PST autoSchedule on off



Scheduler Screen



This screen is accessed from the "Schedule" icon in the lower right corner of the display. This screen will allow scheduling of the whole system or parts of the system. The operation of the unit may be set to a schedule. Individual functions, like ESP cell wash function, may be scheduled with this screen. Select a function and drag and drop to a day and time to set the schedule. Press the "Save" to save the schedule  the "Return" icon to return to the previous screen.



M24 license ▼ ▼  

	Sunday	Monday	Tuesday	Wednesday	Thursday	Friday	Saturday
3 am							
6 am							
9 am							
12 am							
3 pm							
6 pm							
9 pm							

starts 00:00:00.00 end 00:00:00.00

  

The sequence of the ESP wash cycle will be displayed during the wash.

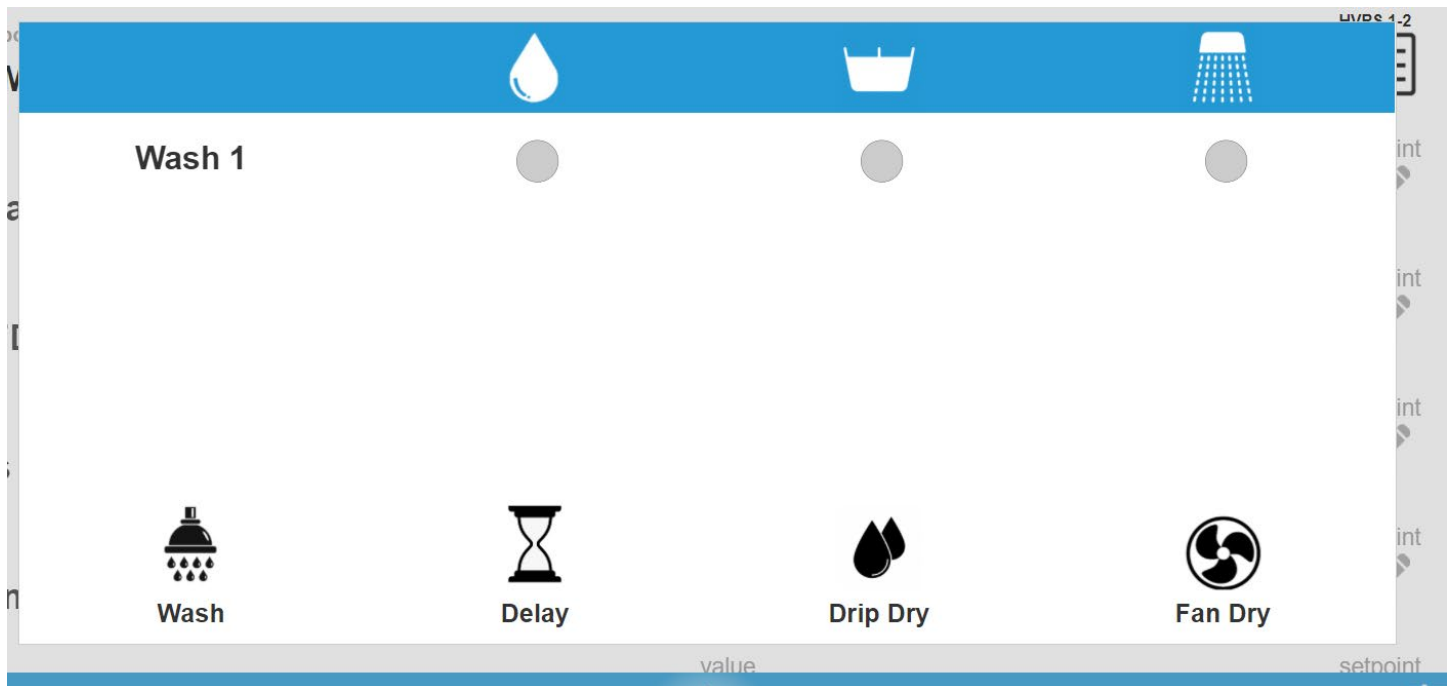

High Voltage Power Supply (HVPS) Screen

Touch the HVPS icon at the upper right corner of the Individual Unit Selection Screen to access this screen, which displays the status of the High Voltage Power Supply that provides the operating current for the ESP cells.

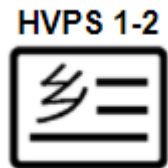

	HVPS 1	HVPS 2
High Voltage Alarm	<input type="radio"/>	<input type="radio"/>
Low Voltage Alarm	<input type="radio"/>	<input type="radio"/>
High Current Alarm	<input type="radio"/>	<input type="radio"/>
High Temp Alarm	<input type="radio"/>	<input type="radio"/>
HVPS OFF	<input type="radio"/>	<input type="radio"/>
Overload	<input type="radio"/>	<input type="radio"/>

Alarm History Screen

This screen is accessed from the "Alarm" icon in the lower left corner of the display. This screen will display your current alarms along with the alarm history.

Time	Status	Description	Action
07:43:02 AM 5 Apr 2022	OffNormal	ECY-303-FFABE1\FAN_CA_GEN_ChangeFilter_AL	Details
07:42:19 AM 5 Apr 2022	Normal	ECY-303-FFABE1\FIL_ELF_DPSensorFault_AL	Details
07:42:19 AM 5 Apr 2022	OffNormal	ECY-303-FFABE1\FIL_ELF_DPSensorFault_AL	Details
07:42:19 AM 5 Apr 2022	Normal	ECY-303-FFABE1\FIL_HEPA_DPSensorFault_AL	Details
07:42:19 AM 5 Apr 2022	OffNormal	ECY-303-FFABE1\FIL_HEPA_DPSensorFault_AL	Details

Touching the icon on the right of the alarm event will display details about each alarm



Time	Status	Description
07:45:00 AM 5 Apr 2022	OffNormal	M24 license\ABS DP sensor alarm
07:44:55 AM 5 Apr 2022	Normal	M24 license\ABS DP sensor alarm
07:42:20 AM 5 Apr 2022	OffNormal	M24 license\ABS DP sensor alarm
07:41:23 AM 31 Mar 2022	OffNormal	M24 license\ABS DP sensor alarm

ASSEMBLY INSTRUCTIONS

Connection of Inlet Transtion/Exit Ductwork

1. The exhaust duct connection at the inlet entrance to the PolluStop system must be continuously welded all around and liquid tight (See figure 1). Remove all filtration media from the filter module before welding. Be sure all flammable materials are removed from area before welding on this unit. Take all reasonable precautions while welding to prevent fire or injury.
2. The duct must be transitioned from its original size to match the full opening of the filter module inlet.
3. All fan outlet openings to which ducts are attached will be provided with a discharge collar (See figure 2).
4. Inlet and outlet openings of the PolluStop unit are to be transitioned to the appropriate inlet and outlet duct sizes.
5. Module to module connections must be made as per UL listed procedure. There is a red silicone sponge interior gasket and an outside Vermiculite coated braided gasket at each mating flange. Run a minimum 1/4" bead of included DAP Fire Stop Silicone Sealant around the outside of the braided gasket before placing the modules together. When the modules are connected together the mating flanges are pre-drilled through for fastening together with machine screws (1/4" x 20) and nuts. The sides and top flanges for joining the modules together are exterior flanges. The bottom flange is an interior flange and must be accessed inside the unit. Remove filters or ESP cells as needed to access this flange. In addition to the machine screw fasteners a U shaped cap must be driven onto this flange before tightening the fasteners. (See illustrations on next page) Tighten fasteners over the U cap. Additionally horizontal 3/8" bolts will fasten the supporting frames together tightly to complete module to module assembly.

FIGURE 1

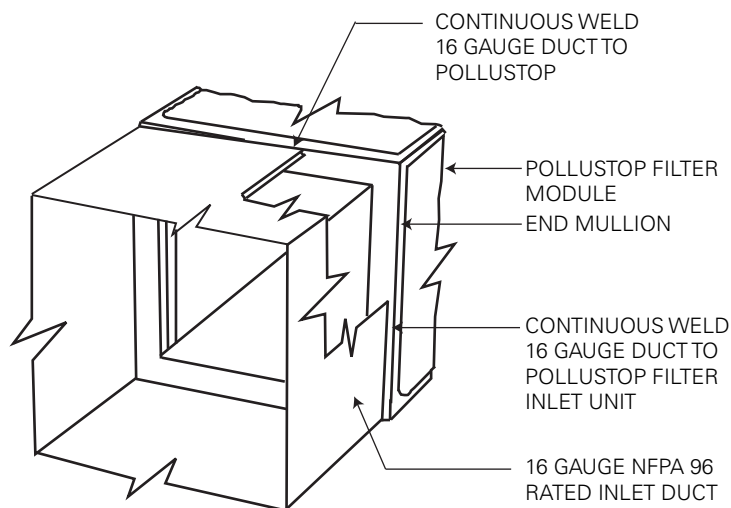
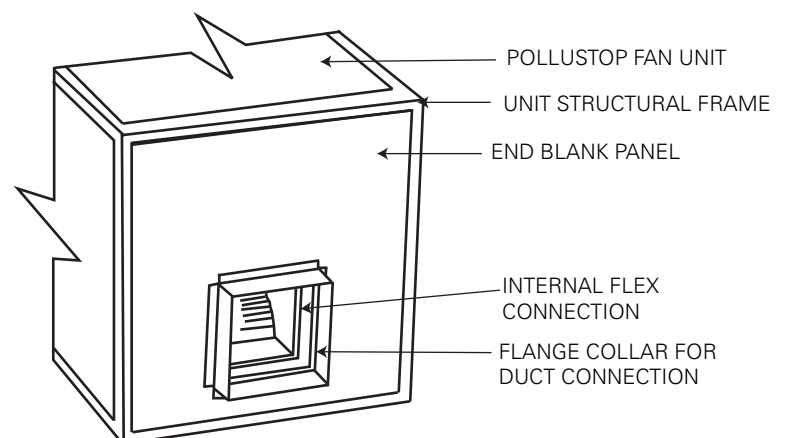
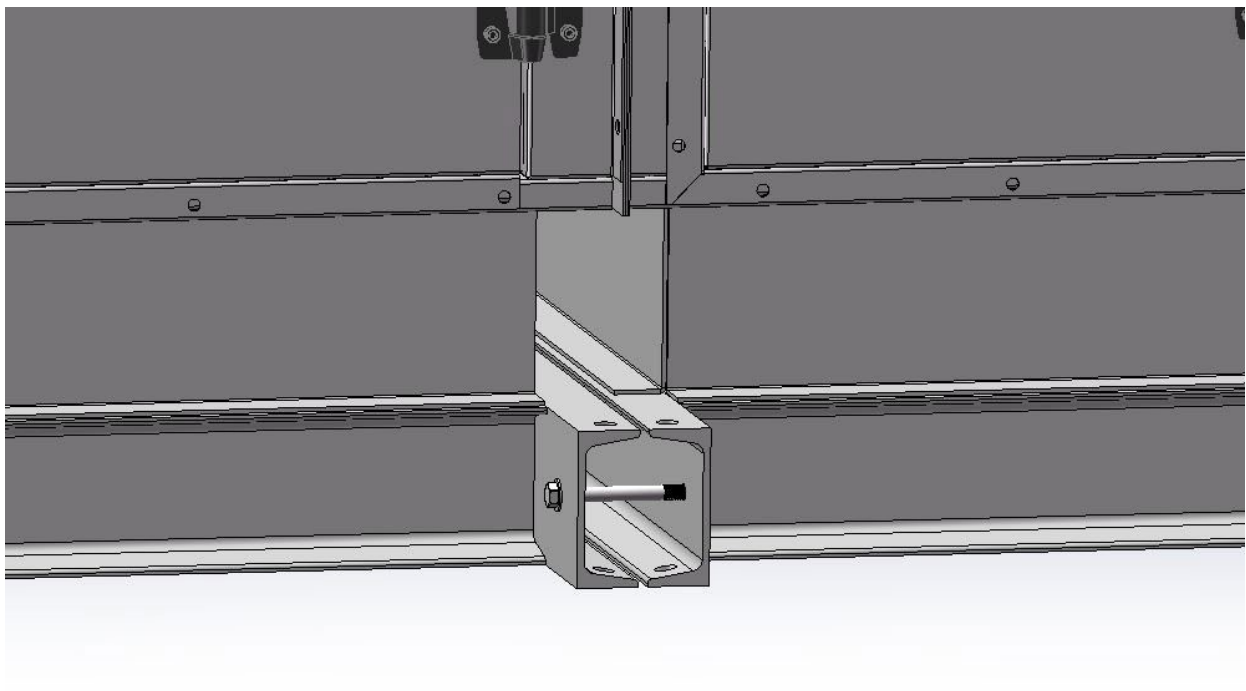
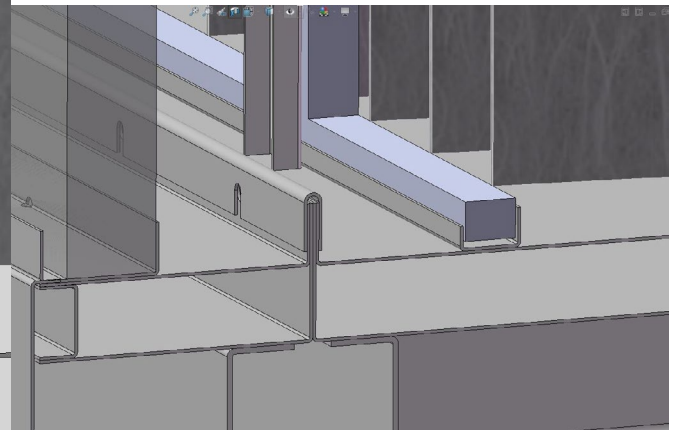
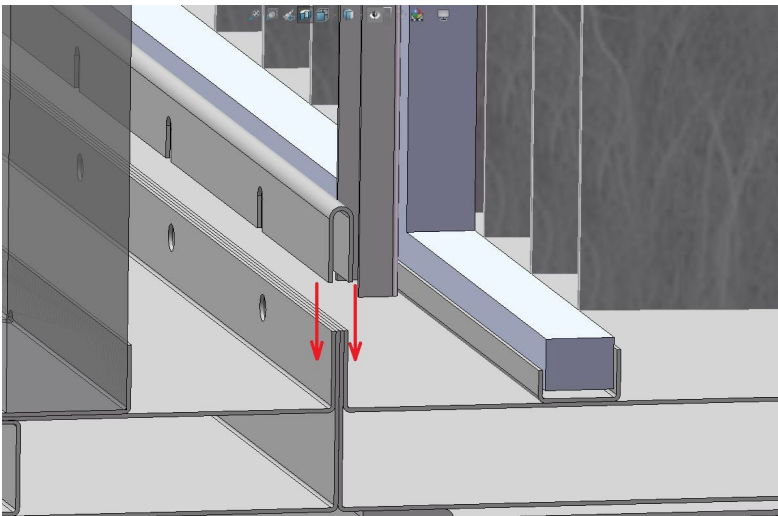
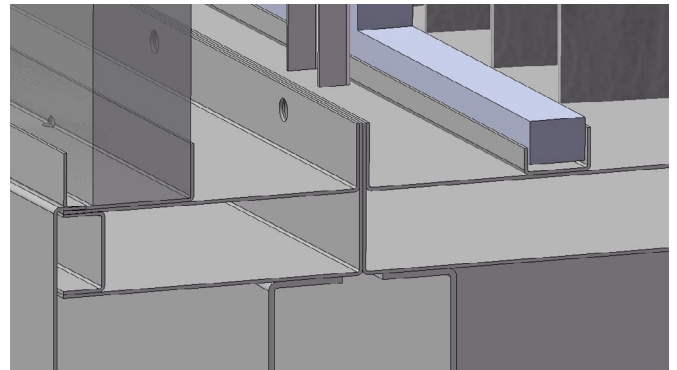
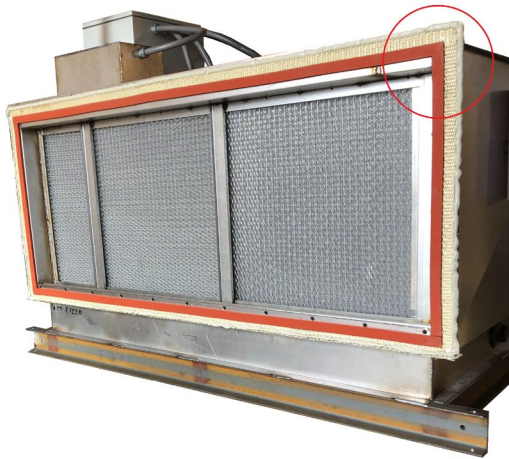

FIGURE 2



Field Connection of Modules



Electrical Connections

1. The main power supply to the PolluStop control panel connects to the line voltage terminal block in the control panel; the wire size will be determined by the electrical rating on the panel rating plate and must conform to national electrical standards.

The following electrical connections are to be made between the PolluStop control panel and various components. These connections are shown in detail on the wiring diagrams included in installers package. Job specific voltages and options are detailed on these wiring diagrams and supersede the general descriptions below.

2. An 8 wire shielded cable runs from the PolluStop control cabinet to the exhaust fan VFD located at the fan module. This signal determines the fan speed.
3. The Fan motor is isolated with a three pole disconnect switch, located in the VFD compartment. Incoming power for the VFD is required to be connected to the L1, L2 and L3 terminals of the disconnect switch.
4. A 6 wire-24 volt DC cable is connected between the PolluStop control panel and the filter pressure transducers located in a cabinet on the filter module.
5. A 4 wire-24 volt cable is connected between the PolluStop control panel and the Cooling Fan start/stop and the firestat.
6. A 4 wire-24 volt DC cable is connected between the PolluStop control panel and the odor control module. (If applicable, the odor control module is optional.)
7. A 3 wire-120 volt/1/60 AC cable is required for the compressor located in the odor control module. (If applicable, the odor control module is optional.)
8. A 2 wire low voltage cable must be run from the PolluStop control cabinet to the normally open (N.O.) dry contacts in the fire suppression system cabinet.
9. A 3 wire low voltage cable is typically run from the N.O. and N.C. contacts of the CR43 relay switch in the PolluStop control panel in case of missing filter(s) in order to shut off the supply power and gas to kitchen appliances. (Optional, this relay is required outside of the U.S.A. but is optional inside the U.S.A.)
10. 4 low voltage wires are connected between the PolluStop control panel and the BMS for make-up air control (Start/Stop and/or 0-10 VDC speed signal).

Schematic Wiring Diagrams

For field wiring diagrams and field connections refer to Halton's job specific shop drawings shipped with the unit or contact the factory for job specific drawings. Be prepared to provide the original Halton drawing numbers, serial numbers, job name or job order number (found on quote or shipping information) to identify proper job drawings.

Additional copies of shop drawings are available on request.

Start Up Notice for units without ESP Module

The unit is now ready for start-up. The start-up and initial inspection are to be performed by an “authorized” service agent. If the start-up is performed by personnel other than an “authorized” agent the Warranty is null and void.

Halton must have a minimum notice of two weeks to schedule start-up. Should the equipment not be ready for start-up at the specified time any additional expenses incurred will be charged to the dealer who purchased the equipment.

For any questions please contact Halton Service Network at startups.us@halton.com or (270) 237-5600 for the U.S. and (905) 624-0301 for Canada.

Start Up Operating Instructions

IMPORTANT: Initial system start-up and certification by factory authorized personnel only. Operating system prior to certification will void warranty.

- Turn on main disconnect switch at PolluStop fan.
- The PolluStop filter unit is designed to operate with the following pressure drops across each filter stage (measured in inches of water column). The lower number is initial reading for a clean filter, the higher number is the alarm set point.
 1. ELF Bag Efficiency Filter 1.24” to 2.0”
 2. Final Efficiency Filter 0.64” to 2.0”

When the pressure drop for each filter bank exceeds the upper limits the alarm button will flash and alarm information will display on the Filter Status Screen, Ecolo Status Screen, Alarms Screen and an alarm button will also flash on the Calibration Screen.

The alarm is a warning only, and does not shut the system down. At the Alarms Screen the alarm can be acknowledged by pressing the Acknowledge button. Pressing the Alarms Acknowledge button will confirm and show acknowledgement that the current alarm(s) have been viewed/corrected. The alarm history is also displayed. The color of the alarm information text indicates the alarm status. If the text is black the alarm is current and not acknowledged. If the text is green the alarm is not current and returned to normal. If the text is red the alarm is current and has been acknowledged.

- There are two other alarm conditions:
 1. “A filter not in place” sensing system. 2) A fire stat to sense excessive temperatures in the duct. Should either alarm be triggered, the audible/visual alarm will sound, an indicator light labeled “filters overall” will be illuminated, and the system will shut down. After the cause of the alarm has been corrected, the system can be restarted by pushing the reset button and also turning the main disconnect switch to the “OFF” position then back to the “ON” position.

Start Up Check List

- 1.1 Before putting any fan into initial operation, the manufacturer's instructions should be followed. Transportation, handling, and installation can cause fasteners to loosen, and cause misalignment of fan components. Carefully follow this check list when commissioning equipment.
- 1.2 Lock out the primary and all secondary power sources.
- 1.3 A complete inspection should be made of all the ductwork and the interior of the fan. Make certain there is no foreign material which can be drawn into or blown through the fan or ductwork. Appropriate protective measures and safety practices should be observed when entering or working within these areas. These measures might include the use of goggles, respirators, or other personal protective devices.
- 1.4 Make sure the foundation or mounting arrangement and the duct connections are adequately designed and installed per drawings and in accordance with recognized acceptable engineering practices and with the fan manufacturer's recommendations.
- 1.5 Check and tighten all bolts, fasteners, and set screws as necessary .
- 1.6 Check the fan assembly and bearings for proper grounding to prevent static electricity discharge.
- 1.7 Ensure power and drive components such as motor starter, variable frequency drive, or hydraulic power unit are properly sized, matched , and connected to the fan.
- 1.8 Check bearing for recommended lubricant and lubrication amount.
- 1.9 Spin the rotation assembly to determine whether it rotates freely, without hitting anything, and is not grossly out of balance.
- 1.10 Inspect impeller for proper rotation for the fan design.
- 1.11 Check alignment of drives and all other components.
- 1.12 Check the belt drive for proper sheave selection and installation and make sure the sheaves are not reversed (excessive speeds could develop).
- 1.13 Check for recommended belt tension.
- 1.14 Properly secure all safety guards.
- 1.15 Assure that all appropriate warnings have been put in place.
- 1.16 Secure all access doors to the fan and ductwork.

START UP CHECK LIST Continued...

- 1.17 Momentarily energize the fan to check the direction of rotation. Listen as the fan coasts to a stop for any unusual noise, identify the source, and take corrective action as necessary.
- 1.18 Switch on the electrical supply and allow the fan to reach full speed. Check carefully for:
- a) Excessive vibration
 - b) Unusual noise
 - c) Proper belt alignment
 - d) Proper lubrication
 - e) Proper amperage, voltage, or power values.
 - f) If any problem is indicated, SWITCH OFF IMMEDIATELY.
 - g) Lock out the power supply. Secure the fan impeller if there is a potential for wind milling. Check carefully for the cause of the trouble, correct as necessary, and repeat check list procedure.
- 2.0 Even if the fan appears to be operating satisfactorily, shut down after a brief period, lock out the power supply, and recheck item 1.5 through 1.17 as the initial start-up may have loosened the bolts, fasteners, and set screws.
- 3.0 The fan may now be put into operation, but during the first eight (8) hours of running, it should be closely observed and checked for excessive vibration and noise. At this time checks should also be made of motor input current and motor and bearing temperatures to ensure that they do not exceed manufacturer's recommendations.
- 4.0 After eight (8) hours of operation, the fan should be shut down and the power locked out. Check list items 1.5 through 1.17 should be inspected and adjusted, if necessary.
- 5.0 After twenty-four (24) hours of satisfactory operation, the fan should be shut down (locked out) and the drive belt tension should be readjusted to recommended tension.
- 6.0 After commissioning and start-up, the fan should be operated and maintained in accordance with the manufacturer's and component manufacturer's recommendations.

For any questions, please call Halton Service Network at US (270) 237-5600 or Canada (905) 624-301.

MAINTENANCE

Maintenance Instructions

NOTE: Heavy hamburger type operations require extra maintenance and frequent filter changes. We recommend a maintenance contract be set up for this type of operation.

MONTHLY:

- Check condition of air filters. Replace if necessary.
- Check odor control liquid level. Replace if necessary.
- Check odor nozzle condition (check for debris)

QUARTERLY: (to be performed by a qualified service agent).

- Check belt tension at exhaust fan. Tighten as required.
- Check belt alignment.
- Lubricate motor bearings.
- Lubricate fan bearings.
- Check contacts on motor starter in control panel.
- Check amperage draw of fan motor.
- Check to see if the overall filter warning system operates correctly. This can be done by removing the final filters and starting the system.
- Check fusible link on the fire dampers (filter section)
- Check ESP cell wash manifolds for clogged or corroded spray nozzles

When replacing belts when multiple belts are used, they **MUST ALL BE REPLACED**, as they are a matched set.

Routine Maintenance

1. A preventive maintenance program is an important aspect of an effective safety program. Consult the manufacturer or other qualified service agents with question concerning changes observed during periodic inspections and routine maintenance.
2. The fan manufacturer's operating and maintenance recommendations, as well as the components manufacturer's instructions (such as motor, bearing, drives, etc.) should be strictly followed.
3. Maintenance should always be performed by experienced and trained personnel who are aware of the hazards associated with rotating equipment. Do not attempt any maintenance on a fan unless the fan power supply has been locked out and tagged out and the impeller has been secured.
4. When performing maintenance functions which include disassembly of the fan, careful consideration should be given to the size, weight center of gravity, and lifting means of the fan components. It should also be noted that the outboard bearing on some fans such as arrangements 1, 8, 9 and 10 is often cap-loaded. Removal of the securing means may result in a sudden change in impeller position.
5. Historical data is often the best indicator for determining the operational condition of the fan. Maintenance logs which include lubrication, vibration levels, temperature levels, power requirements, inspection, and other pertinent records should be maintained and consulted as

necessary when assessing the condition of the fan.

6. Under normal circumstances, handling clean air, the system should require cleaning only once a year. However, the fan and system should be checked at regular intervals to detect any unusual accumulation.
7. The fan impeller should be specially checked for build-up of material or dirt which may cause an imbalance with resulting undue wear on bearings and belt drives. A regular maintenance program should be established as needed to prevent material build-up.
8. Periodic inspection of the rotating assembly should be made to detect any indication of weakening of the rotor because of corrosion, erosion, or metal fatigue. Where signs of deterioration are found, lock out and tag out the impeller until the unit had been inspected and approved by a qualified consultant.

Filter Section Maintenance

Filter Replacement

Note: Halton filters should be used to avoid the need to re-calibrate.

To replace filters, proceed as follows:

1. Shut off fan at the Halton Control Panel.
2. Shut off the power feeding the blower fan at the building source panel.
3. Loosen the access door latches and open door.
4. Check how filters are set in place to prevent air by-pass.
5. Remove all filters by sliding out the filter along bottom of filter track.
6. Slide the new filters along the bottom filter track and seat properly along filter by-pass gasket. Replace all filters in this manner. Ensure all filters are seated properly.
7. Close access door and lock all latches.
8. Turn on the power feeding the blower fan at the building source panel.
9. Start the fan at the Halton Control Panel.
10. Wait 5 minutes for the touch screen display of filter life to update.

Filter Quantity Chart

MODEL	CAPACITY	ELF BAG FILTER		FINAL FILTER	
		MERV 14		MERV 16	
		FULL SIZE 24"X24x2"	HALF SIZE 24"x12"x2"	FULL SIZE 24"x24"x12"	HALF SIZE 24"x12"x12"
PST3	3000	1	1	1	1
PST4	4000	2	0	2	0
PST5	5000	2	1	2	1
PST6	6000	2	2	2	2
PST8	8000	4	0	4	0
PST10	10000	4	2	4	2
PST12	12000	6	0	6	0
PST15	15000	6	3	6	3
PST18	18000	9	0	9	0
PST20	20000	9	3	9	3
PST24	24000	12	0	12	0
PST28	28000	12	4	12	4
PST32	32000	16	0	16	0
PST36	36000	16	4	16	4
PST40	40000	20	0	20	0

Filter Integrity Monitor (FIM)

The Filter Integrity Monitor is a grease monitoring system that detects when grease is getting past the final filter in the Halton PolluStop system. It can detect if the final filter in the PolluStop unit is partially missing due to filter gaps, or if a lower efficiency final filter is being used than specified. If FIM alarm is active, a Pop up will appear over Final filter display on the main page indicating the need to check for missing filter or filter gaps.

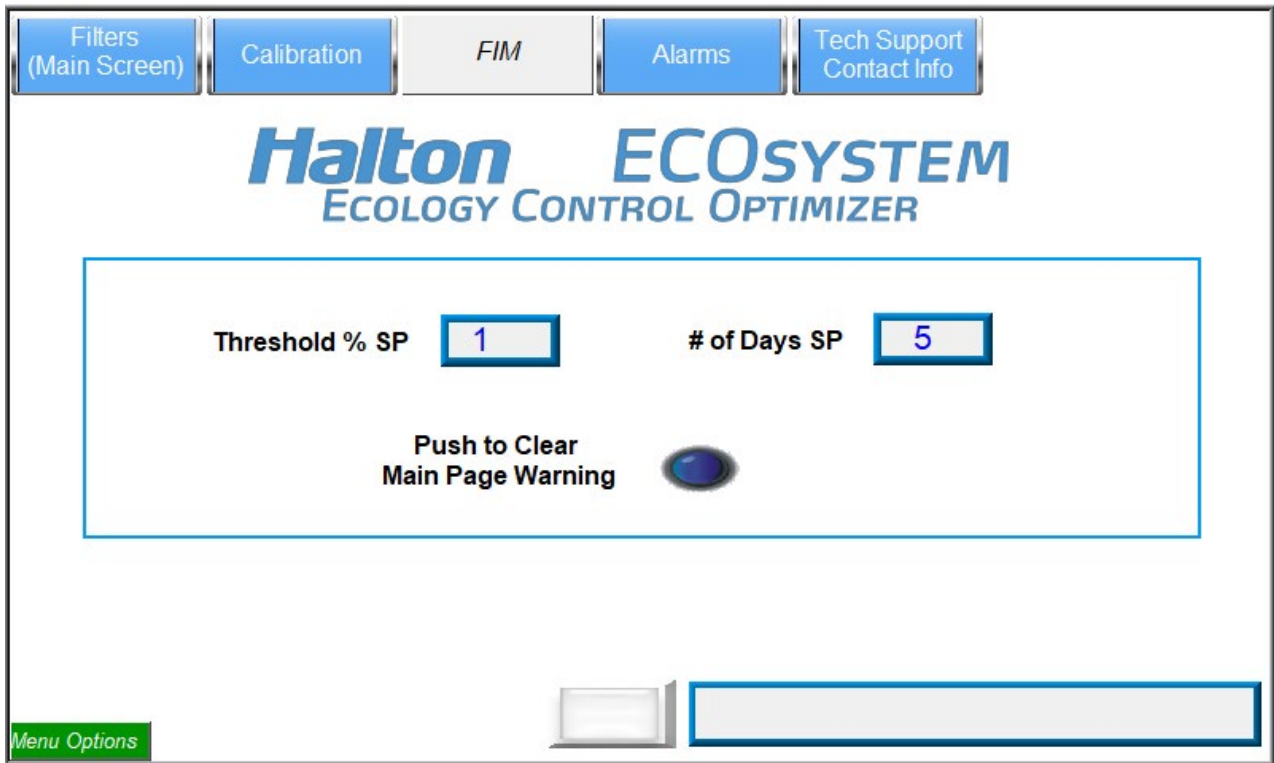

To check the filters, proceed as follows:

1. Shut off fan at the Halton Control Panel.
2. Shut off the power feeding the blower fan at the building source panel.
3. Loosen the access door latches and open door.
4. Check that the filters are Halton supplied.
5. Check how filters are set in place to prevent air by-pass. There should be no gaps or spaces between filters or between filters and the unit's filter support structure.
6. Close access door and lock all latches.
7. Turn on the power feeding the blower fan at the building source panel.
8. Start the fan at the Halton Control Panel.
9. Wait 5 minutes for the touch screen display of filter life to update.

Once FIM alarm is active go to FIM page on the touchscreen to clear alarm once filter integrity is checked.

Pressure Transducer Air Tube Parts

1	Pressure Transducer Air Tube
2	Pressure Transducer Air Tube Connecting Nut
3	Elbow
4	16 Gauge Top Panel
5	Elbow Lock Nut
6	Mullion
7	16 Gauge Bottom Panel
8	Structural Base
9	Fire Proof Door Gasket
10	Filter By-Pass Gasket

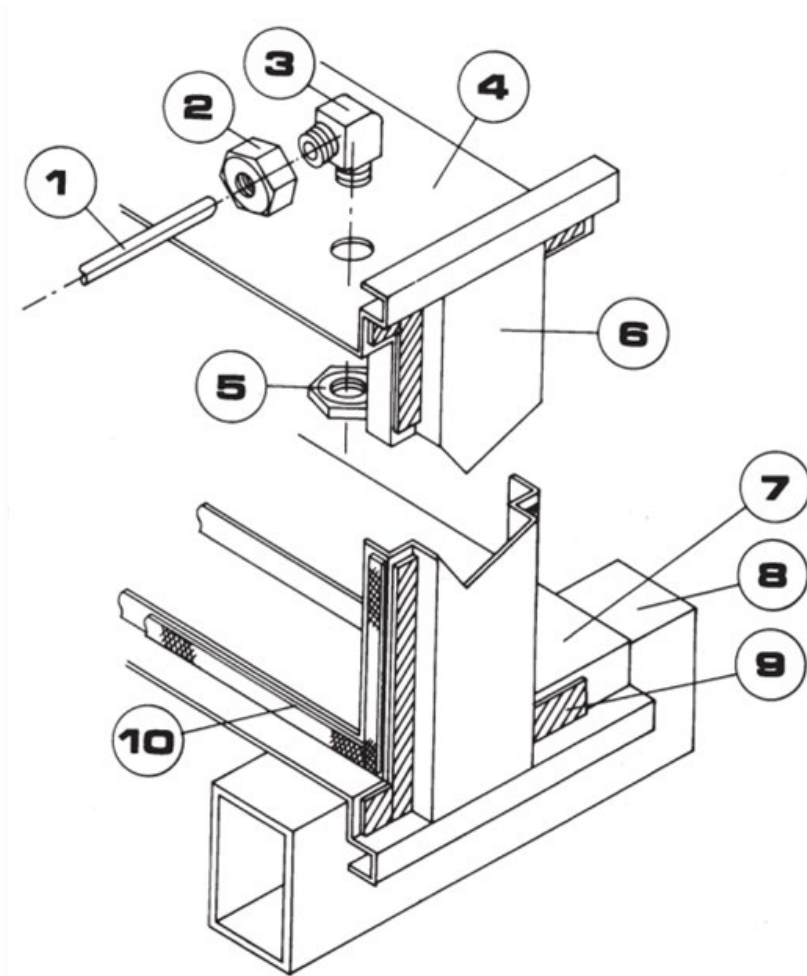

ESP Module Maintenance

OPERATION AND MAINTENANCE

IMPORTANT

The PolluStop unit is designed to remove sub-micron, airborne particulate generated from cooking processes. This system is NOT INTENDED to eliminate regular hood and ductwork cleaning and service.

WARNING: FAILURE TO FOLLOW THE INSTRUCTIONS SET FORTH IN THE OWNER'S MANUAL FOR THE INSTALLATION, OPERATION, AND REGULAR MAINTENANCE OF THE ELECTROSTATIC PRECIPITATOR MAY CREATE A FIRE HAZARD AND VOIDS THE LIMITED WARRANTY SET FORTH IN THE OWNER'S MANUAL.

Introduction

Halton uses high-efficiency electrostatic ionizing collecting cells to capture and retain sub-micron particulate, and features an integral wash system to automatically clean the dirty ionizing-collecting cells. Regular maintenance is also required (see page 8). A programmable logic controller (PLC) controls and monitors overall system operation. The controller may be programmed to operate automatically or manually, in order to meet individual customer needs.

Operation

Power to the system is controlled by a disconnect switch on the control panel. The disconnect must be in the ON position for the system to operate. The operation of the PolluStop system falls into four main categories:

NORMAL: System collects particulate from the air stream

WASH: System goes through cycles to clean and dry dirty ionizing-collecting cells

RESET: Returns the system to the NORMAL mode if a WASH cycle is accidentally initiated

STANDBY: Waiting period after a WASH mode

NOTE: As a safety precaution, the system will only operate in the NORMAL mode when the access door of the unit is completely closed and the plunger of the red door safety switch is fully extended. If the red door safety switch is not fully extended, the PRIMARY POWER and HIGH VOLTAGE lights will not illuminate on the touch screen interface, nor will the red POWER light and clear HIGH VOLTAGE light illuminate on the power pack.

During operation in the NORMAL mode, depressing the *EMERGENCY STOP* button will immediately shut down the system. The red ALARM light will illuminate until the button is released. The system will continue to operate in the NORMAL mode after the *EMERGENCY STOP* button is released.

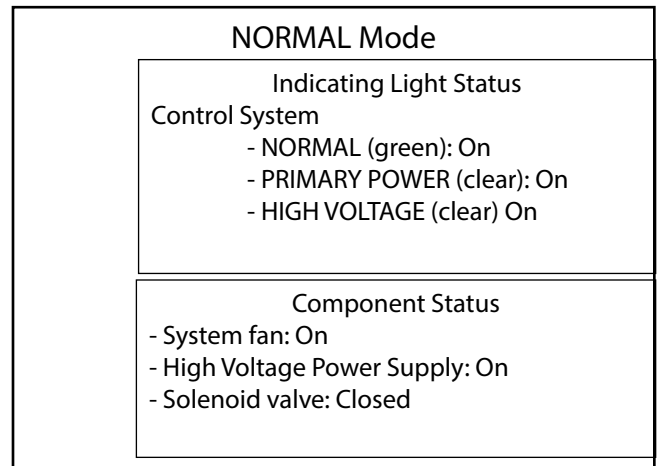

Figure 6. NORMAL Mode Indicating Light and Component Status

Washing

Halton's PLC control is pre-programmed to manually initiate and cycle through the wash, rinse, dry and system standby steps, as described below.

To initiate a wash manually, with the system in the NORMAL mode, turn the system to "OFF", then touch the Initiate Wash button on the main screen of the touch panel. Note that the system will not wash in the "ON" position, as it interprets this as the fan and electrostatic filter should remain in operation. The WASH mode consists of 6 steps. Figure 7 describes the indicating light and system component status while operating in the WASH mode. After the WASH cycle is completed, the system defaults back to the start/stop schedule or on/off button. As indicated in Figure 7, there is a 5 minute delay period, after wash initiation, before the wash process begins. If the WASH cycle is accidentally initiated, the operator may reset the system during the 5 minute delay period, and the system will return to NORMAL operation. If the system is reset after the 5 minute delay period, the WASH cycle will be accelerated and the system will return to the NORMAL mode after the WASH cycle is complete. During operation in the WASH mode, depressing the EMERGENCY STOP button will immediately shut down the system. The red ALARM light will illuminate until the button is released. The system will continue to operate in the WASH mode after the EMERGENCY STOP button is released.

Reset Mode

On rare occasions, it may be necessary to reset the system. This may be required if a WASH cycle is inadvertently initiated. As indicated previously in Figure 7, there is a 5 minute delay period after the WASH button is pushed, before the wash process begins. If the WASH cycle is accidentally initiated, the operator may reset the system during the 5 minute delay period, and the system will return to NORMAL operation. If the system is reset after the 5 minute delay period, the WASH cycle will be accelerated and the system will return to the NORMAL mode after the WASH cycle is complete.

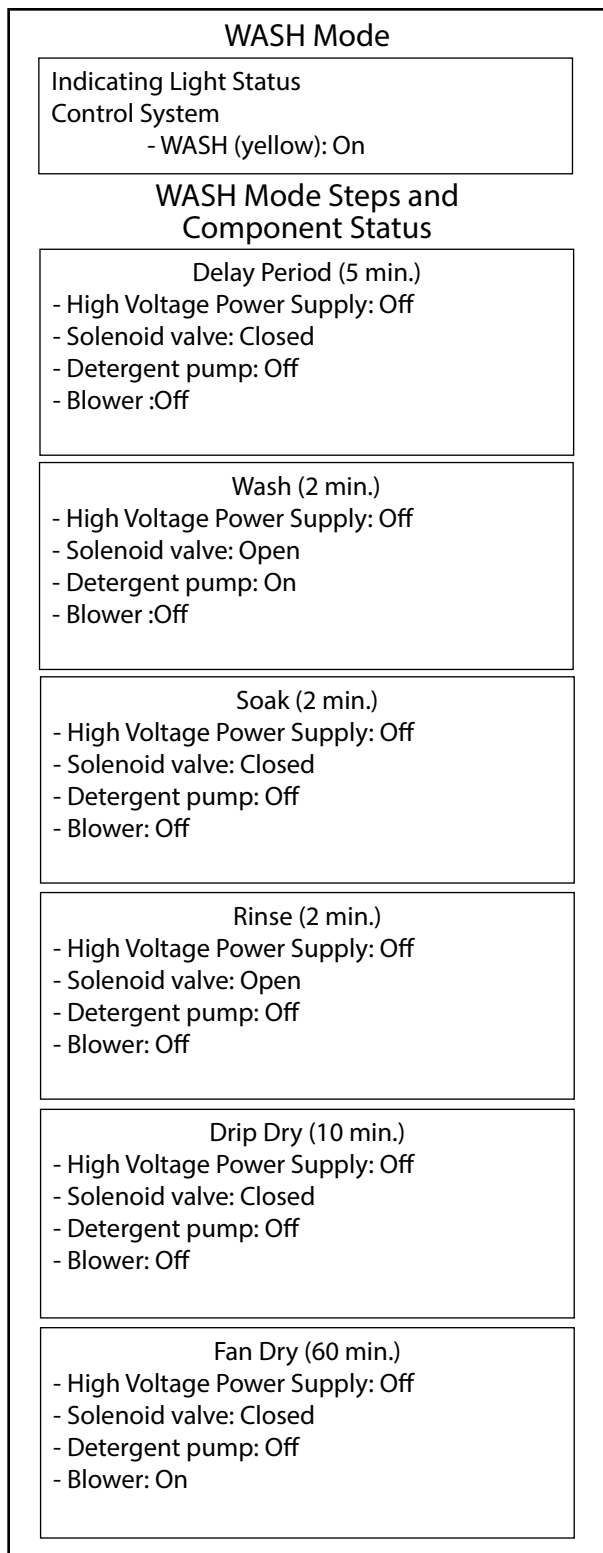

Figure 7. WASH Mode Indicating Light and Component Status

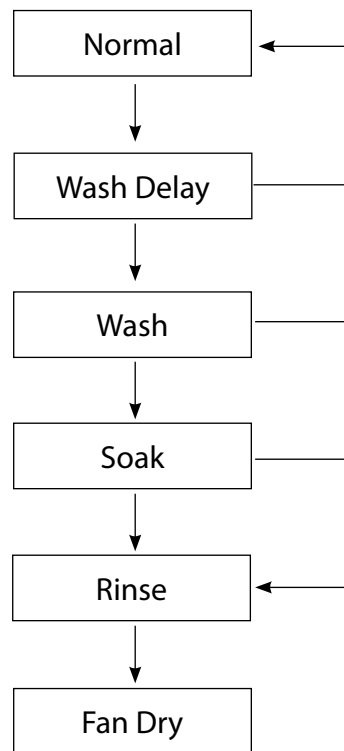

Figure 8. RESET Mode Sequencing

WASHING (continued)

Figure 8 illustrates the sequence of events that occurs when the system is reset during the different stages of system operation.

When the system is in the RESET mode, the “Reset On” indicator will be highlighted on the control panel touch screen.

Detergent Dispenser

General

The detergent dispenser supplies detergent to the wash system during the WASH mode. The detergent dispenser is designed to operate for the entire duration of the WASH mode (default setting is 2 minutes), and the amount of detergent delivered is regulated by the flow control valve. The detergent reservoir holds approximately 5 gallons of detergent concentrate. The DETERGENT LOW light will illuminate when the amount of detergent in the reservoir drops below approximately 3/4 gallon. The reservoir should be refilled immediately after the DETERGENT LOW light comes on, to ensure that detergent is dispensed and to prevent pump damage. NOTE: When DETERGENT LOW light is on, no detergent is dispensed during the wash cycle. Refill immediately.

Adjustments

The liquid level sensor was setup during field inspection and should not require further adjustment.

Flow Control Valve Adjustment:

The detergent dispenser flow control valve was set during commissioning to a detergent-to-wash water ratio of 0.1:20, meaning 1/10 of a gallon of detergent is used for every 20 gallons of wash water used. In some applications, the amount of detergent used may need to be increased. This may be done by adjusting the flow control valve on the upper left front of the detergent dispenser (Adjustments to the flow control setting should be done in small increments over a period of several wash cycles. Turning the knob clockwise, increases the amount of detergent used during a wash cycle).

Detergent

Halton ESP-475 detergent concentrate is recommended as it has been specially formulated for this type of equipment and will help ensure successful operation and optimum performance. Substituting other types of detergent may result in decreased system performance, system shutdown or voided limited warranty. Contact 270-237-5600 for USA and 905-624-0301 for Canada.

Detergent Cabinet

The Detergent Cabinet has a lower space that may be used to store an extra 5 gallon container of detergent concentrate. The extra container is not included, but may be purchased from Halton.

Maintenance

Routine service is required in order to ensure optimum performance and reliability of the system.

A. Aluminum Mesh Pre & Post Filter - These metal filters in the precipitator should be removed and thoroughly cleaned on a minimum 2 week interval, removing any grease and particulate buildup.

B. Ionizing-Collecting Cells - The ionizing-collecting cells should be inspected for grease buildup on a monthly basis. This monthly maintenance should be done after the system completes a wash cycle. If grease buildup is apparent, remove cells and clean manually. The cells should be manually cleaned every 6 months minimum. Please see section below Ionizer-Collector Cell Maintenance for inspection and cleaning instructions.

C. Safety Bag Filters - Safety filter replacement frequency depends on the volume of cooking. Change filters prior to an increase in resistance that affects hood capture efficiency. See ordering instructions in this manual.

D. Activated Carbon Panels - Carbon panel replacement frequency is also dependent on the volume of cooking. Replace when an increase in odor breakthrough is first noticed. Change out may occur between 3 to 6 months. This is only a guide and the frequency may be less or greater dependent on the cooking operation. Solid fuel applications will require more frequent changes.

E. System Blower/Motor - Blower, motor and drives should be inspected, serviced and cleaned according to the manufacturer's instructions, annually.

To access the pre and post mesh filters and ionizing collecting cells, follow these instructions.

1. Rotate the disconnect knob on the upper right hand corner of the system control to the OFF position. "Lock Out" the system by flipping the red lever in the handle outward and securing it with a padlock.
2. Open the access door by turning the knob on the red safety switch until the plunger is fully retracted, then un-latch the door. Using a well-insulated device (such as a screwdriver with insulated handle), short the cell bars to the grounded plate behind them to ensure they are discharged.
3. Slide the metal mesh filters from the tracks.

1. Thoroughly clean the metal mesh filters using hot water and a mild detergent or degreaser.
2. Reinstall the filters in the tracks.
3. Remove the collector cells retaining brackets using a 7/16" wrench.
4. Remove the red and blue high voltage cables and jumper cables by firmly grasping the red boots and pulling them from the high voltage plugs.
5. With a partner carefully remove a cell from the cabinet. Each cell weighs up to 42 lbs., so use caution when handling. Use care not to bend or dent the collecting plates or framework and be aware of the fragile ionizer wires in the front of the cell.
6. Carefully inspect the cell for bent or broken ionizing wires. Damaged wires should be removed and replaced (contact parts and service at 270-237-5600 for USA and 905-624-0301 for Canada).
7. Carefully inspect the cell for bent collector plates. Bent plates may be carefully straightened by hand.
8. Inspect the cell for residual grease that was not removed during the wash process. Excessive grease buildup indicates that the cells need to be removed from the cabinet and thoroughly cleaned, following the procedures under Ionizing-Collecting Cells.
9. Examine the cell spray nozzles for clogged or corroded nozzles. Replace nozzles found to be clogged or corroded. Nozzles may be scrubbed with a soft brush. Never use metal brushes, wires or probes to unclog nozzles.
10. Reinstall the cell to the same location from which it was removed. The serrated ionizing blades of the cell should be facing upstream.
11. Reinstall the high voltage cables, and cell retaining bracket.
12. Close the access door completely, latch the door, and turn the knob on the red safety switch until the plunger is fully extended and the knob will no longer turn.

Ionizer-Collector Cell Maintenance

The ionizing-collecting cells should be inspected for grease buildup on a monthly basis. This monthly maintenance should be done after the system completes a wash cycle. If collected grease, smoke buildup is apparent, remove cells and clean manually. The cells should be manually cleaned every 6 months minimum.

Caution: Cells weigh 41 lbs. (2' cell). It is advisable to wear mechanics gloves to prevent injury from any

sharp metal edges. Use extreme care when handling and transporting cells. Dropping a cell can damage the high voltage insulators. Bent or misaligned collector plates will result in a short circuit. It is advisable to use a professional that is experienced in servicing electrostatic precipitators.

Prior to gaining access to the ionizer-collector cell section make certain that the primary electrical power to the system is turned off and locked out. Then turn off the ON/OFF rocker switch, located on the high voltage power pack front panel.

Next locate the red safety switch mounted on the ionizer-collector cell access door and rotate the knurled knob so that the switch barrel is withdrawn and the access door can be opened. Unlatch and open the access door. On each tier of cells, short each of the three vertical bus bars to ground/earth, using an insulated handle screwdriver. Unplug the red and blue cables from the top tier of cells and temporarily tie the cables off so they are not subject to damage when the cells are removed. If there are multiple tiers of cells, remove the red and blue jumper cables that connect each tier. Store the jumper cables in a safe place for reuse later.

On each cell tier, remove the two 7/16" hex-head screws from the Z-brackets that holds the cell to the supporting cell guide rail. Store hardware and Z-brackets in a safe place for reuse later.

On multi-tier units, cells should be removed from the top-down. Firmly grasp the two vertical bus bars located on the air entering and air leaving sides of the cell and pull the cell towards you. As the rear end of the cell nears the end of the supporting cell guide rail a second person must get in place so that the two person team can safely withdraw and handle the cell, lowering it to the floor. Repeat until all cells are removed, making sure to mark each cell so that it can be returned to its original position in the unit.

In most cases the cells will need to be transported to a site where they can be manually power washed, steam cleaned or placed in a soak tank. If power washing or steam cleaning make sure that the discharge pressure does not warp or bend the cell plates. Wash medium temperature above 200° F can warp/damage the plates. ESP-475 detergent, used in conjunction with the precipitator internal wash system should be used to emulsify the collected grease, smoke, dirt with the water/steam. After all the collected material has been removed, thoroughly rinse the entire cell with clean water. If using ESP-475 and water mixture in a soak tank, leave the cells submerged until the collected material can be rinsed away.

Making sure that all cells are completely dry, re-install using the above instructions, in reverse order.

UV/Carbon Panel Maintenance

UV Cassette Maintenance & Replacement

In normal use the UV Cassette will require no maintenance. The user serviceable parts in the UV Cassette include the Bulbs and the Ballast Boards. A Halton Authorized Service Agent should be contacted for any other service issues. Please call the Halton Service Network at 270-237-5600 or 800-442-5866. If the Cassette must be removed from the UV/Carbon module, remove the ten 1/4-20 machine screws around the perimeter of the face plate (7/16" wrench). Disconnect the amphenol pin connectors between the UV control box and the Cassette. Slide the Cassette out of the module taking great care not to break any of the UV bulbs.

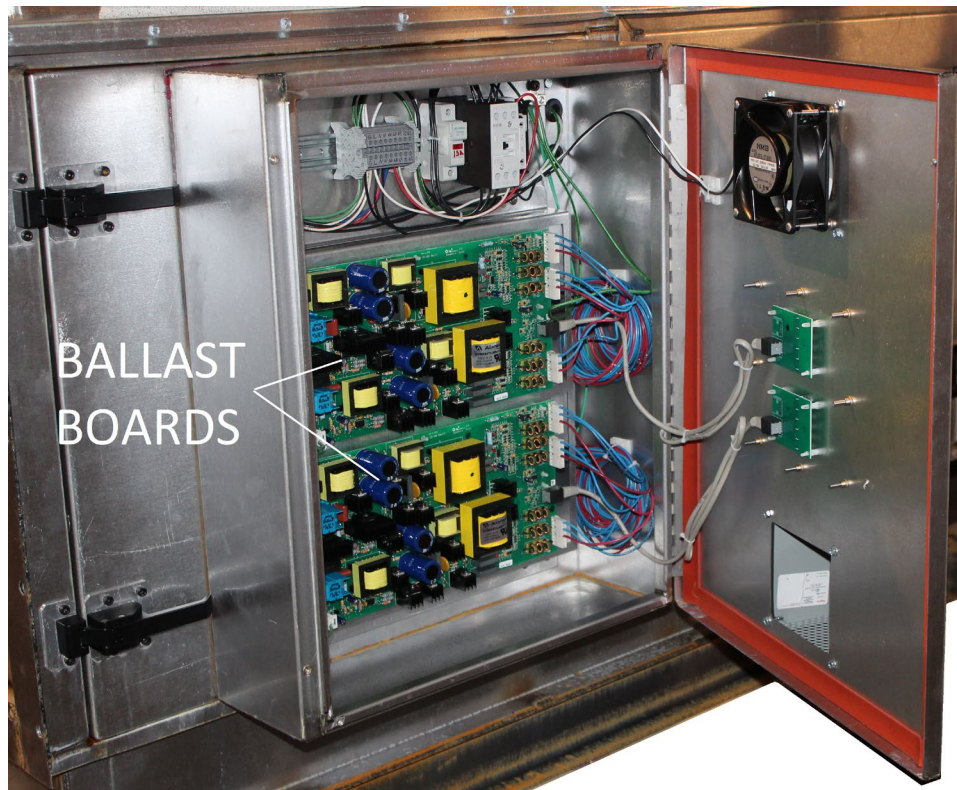
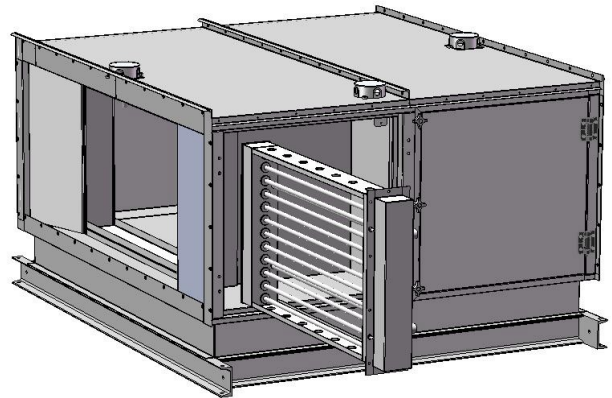

Replacement Parts	Part No.
UV Bulb 38" Cassette	60131
UV Bulb 66" Cassette	60132
UV Ballast	10847 (120V) 10846 (240V)
Nose Odor Sensor	10486
Nose Odor Sensor Cap	12238
Odor Sensor Circuit Board	12234
UV Bulb Status Panel	11039

Replacement Carbon Panels	Part No.
Carbon Panel 24" x 12" x 2"	11858
Carbon Panel 24" x 24" x 2"	11857

Odor Maintenance



Figure 5

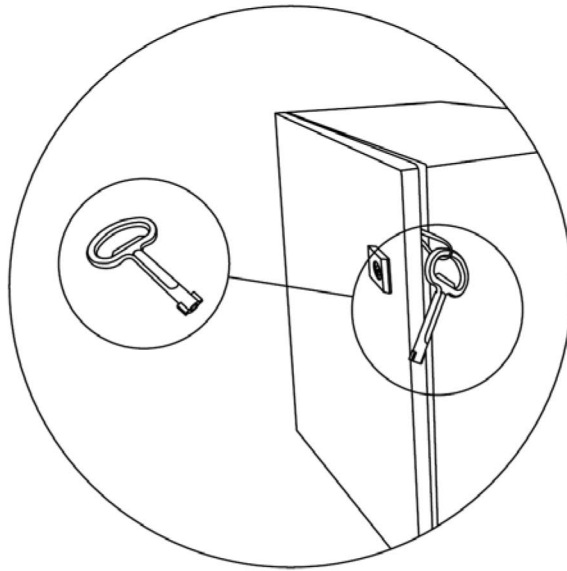

Figure 6



Figure 7



Figure 8

To replace a 5 gallon/22 liter bottle of odor solution (“Scentry”)

1. Turn the odor control section OFF using the switch on the door of the enclosure cabinet.
2. Open enclosure cabinet door using the special key. See Figure 5. (The key ships attached to the door with a zip tie.) See Figure 6.
3. Remove the level probe from the empty bottle/reservoir. See Figure 7.
4. Pull the dip tube assembly out of the empty bottle. See Figure 8.
5. Remove the empty bottle from the cabinet
6. Refill bottle with concentrate and mix well as per instructions or refill with “ready to use”, pre-mixed solution.
7. Place the bottle in the cabinet.
8. Put the dip tube assembly into the bottle. Make sure the dip tube reaches the bottom of the bottle.
9. Place level probe in the bottle.
10. Close the cabinet door and lock with the key.
11. Turn the odor control section ON.

Preparing Odor Control

(The PolluStop Odor Reducing Module is optional)

To prepare a 5 gallon/22 liter bottle of odor solution (“Scentry”) for use.

1. Open enclosure cabinet door using the special key. See Figure 5. (The key ships attached to the door with a zip tie.) See Figure 6.
2. Screw the cap off the bottle/reservoir.
3. Place the low level probe in bottle on the neck of the bottle, taking the place of the cap. See Figure 7.
4. Cut a hole in the bottle for the dip tube. There is an indentation in the top of the bottle next to the handle and opposite the neck where the level probe is. This is the location to cut the hole for the dip tube. There may be a nipple in this location which may be cut off to allow the dip tube to be placed in the bottle. See Figure 8.
5. Put the dip tube assembly into the bottle. Make sure the dip tube reaches the bottom of the bottle
6. Place the bottle into the cabinet.
7. Replace the dip tube or low level control device assembly into the bottle. Make sure the dip tube reaches the bottom of the bottle.
8. Place cap on bottle neck.
9. Close the cabinet door and turn latch $\frac{1}{4}$ turn clockwise.

The Ecolo Unit is set to operate either on a continuous spray or on an intermittent spray cycle while fan is running.

A switch is provided on the Ecolo Control Panel to be activated for the desired application.

The unit when shipped, will be set for a 20 second spray every 1 minute. This can be adjusted in the field to give the required setting for each particular installation.

Setting Ecolo Time On and Time Off Cycle

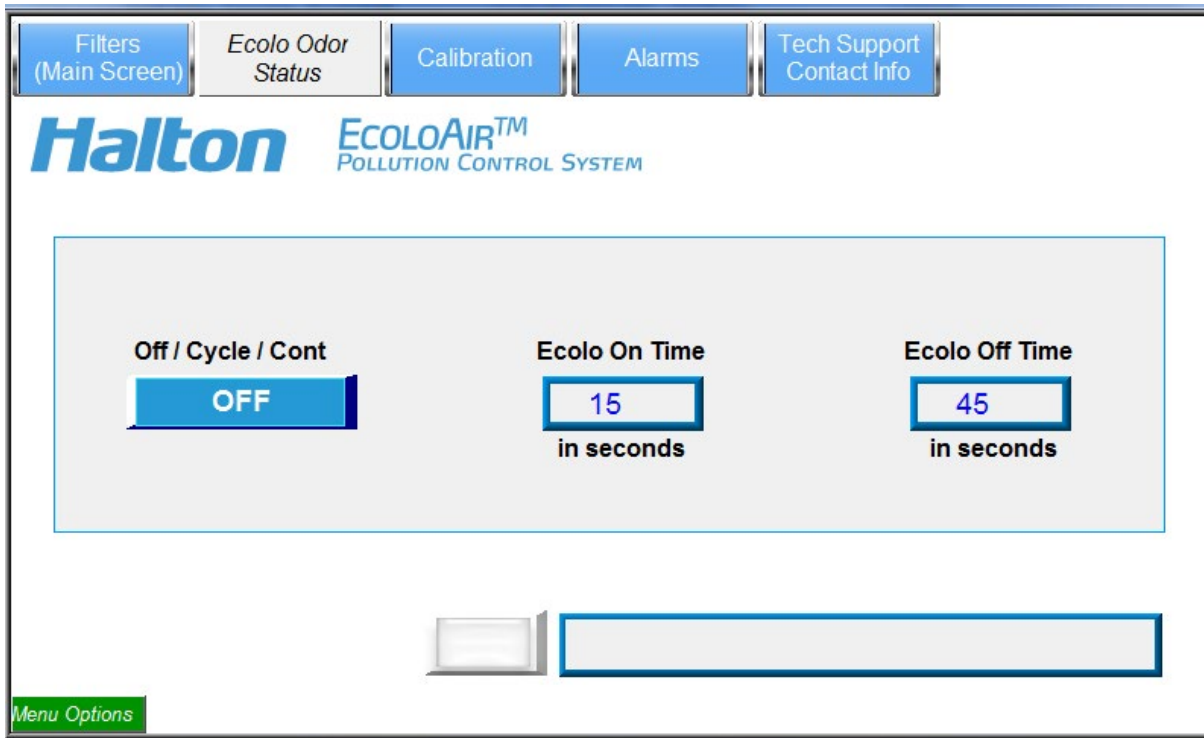

Ecolo odor control unit operation is enabled through the ecolo screen.

The three position selector switch (Off/ Cycle & Continuous) enables the operation of the compressor.

Off - unit is not operational.

Cycle - unit runs in cycles, (on and off).

Continuous - unit runs on all the time, until other command selected.

Numeric display "Ecolo ON time" sets the time in seconds for unit to be on.

Numeric display "Ecolo OFF time" sets the time in seconds for unit to be off.

Once these times are set, if selector switch is in cycle mode, unit will run for a preset time, when this time has been elapsed, the operation of the compressor automatically stops and it will be off for the preset time set in off mode. The status changes again to "on" state and goes in cycles as previously described.

Fan Section Maintenance

Fan Wheel Replacement

It is unlikely the fan wheel will require replacement. However, if the wheel requires balancing, it can normally be done in the field by a certified fan technician. Should the fan wheel require replacement, the work should only be performed by a Halton certified fan technician.

Bearing Replacement

1. Remove belts and the fan sheave. To remove fan sheave, remove the cap bolts and screw them into the threaded holes in the bushing. Snug up all bolts then continue to tighten each cap bolt in half turn increments until the sheave comes loose from the bushing. The bushing and sheave should now slide off the fan shaft.
2. Loosen the set screws on the locking collars of bearing.
3. Remove the fan wheel and fan shaft by sliding the fan shaft out through the bearing collars. Polishing the fan shaft with emery cloth and some light lubrication on the fan shaft will make removal much easier.
4. Remove bolts, fastening the bearing to the top and bottom bearing base plates.
5. Re-install equipment in reverse order of removal. Care should be taken to properly tighten the set screws in the bearing locking collar' see chart for recommended tightening torque of set screws.
6. When replacing the fan sheaves, slide sheave and bushing onto the fan shaft and insert the cap bolts into the non-threaded holes of the bushing and screw into threaded holes in sheave. Tighten each cap bolt a half turn in rotation until tight.
7. Ensure proper belt tension and sheave alignment. The use of straight edge is recommended to ensure proper alignment and maximum efficiency.

Tightening Torque Recommended for Bearing Set Screws

Fan Shaft Diameter		Set Screw Tightening	
Inches	mm	(in.lb.)	(kgm.)
1	25	30	0.04
1 - 3/16	30	40	0.05
1 - 7/16	37	50	0.06
1 - 11/16	43	65	0.08
1 - 15/16	49	65	0.08
2 - 3/16	56	80	0.10
2 - 7/16	62	135	0.16

Exhaust Fan Module

1	Access Door	14	Fan
2	Side Panel	15	Fan Pulley
3	Corner Panel	16	Fan Belt
4	Disconnect Switch	17	Motor
5	Hanger or Lifting Brackets	18	Motor Pulley
6	Spring Isolators	19	Electrical Box Terminal Strip
7	Floating Steel Base	20	Pressure Transducer (optional location)
8	Motor Slide Base	21	Firestat
9	Structural Base	22	Air Tubes for Pressure Transducer (optional location)
10	Bottom Panel	23	Pressure Transducer Box Cover (optional location)
11	Lower Fan Discharge Panel	24	Pressure Tube Cover (optional location)
12	Flexible Connection	25	Top Panel
13	Upper Fan Discharge Panel		

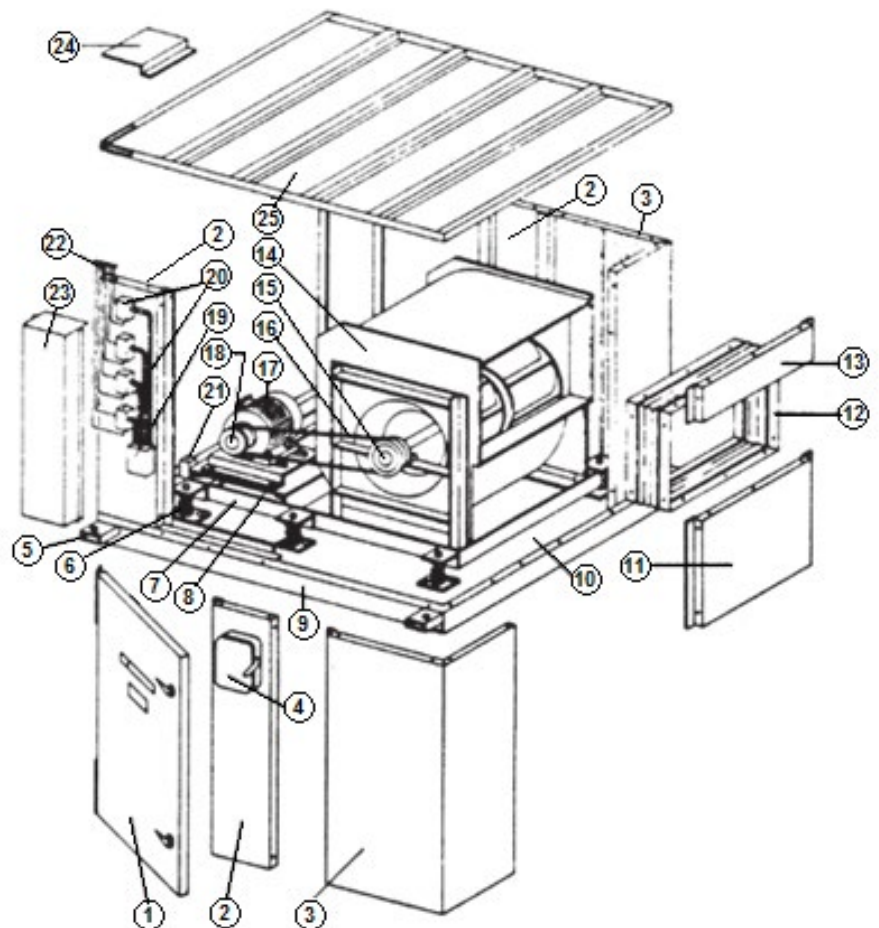

Fan Types

For all models, a double width double inlet Class 2 airfoil type fan is used. The motor and drive package is located in the exhaust airstream. All fan wheels are mounted to facilitate easy removal should adjustment or repairs be necessary.

NOTE: Ensure motor disconnect switch in exhaust fan housing is in OFF position prior to any service work.

Sheave Alignment

Align the drive by the four-point method with a piece of string or a straight edge. The two sheaves will be aligned when two points (near and far) on the face of each of the sheaves touch the straight edge of the string when the string is a straight line. Refer to the figure below for correct alignment.

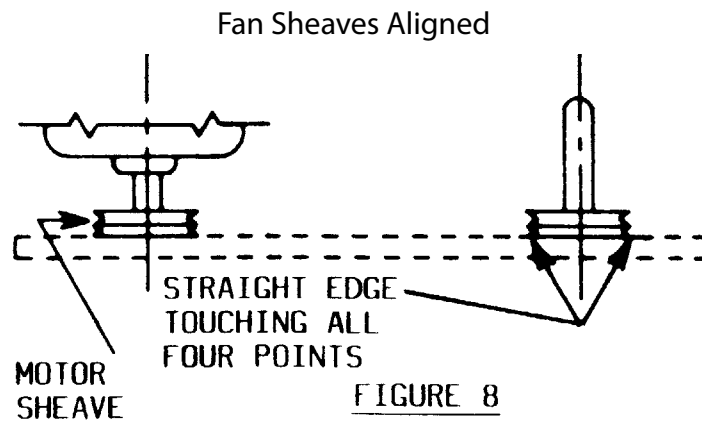
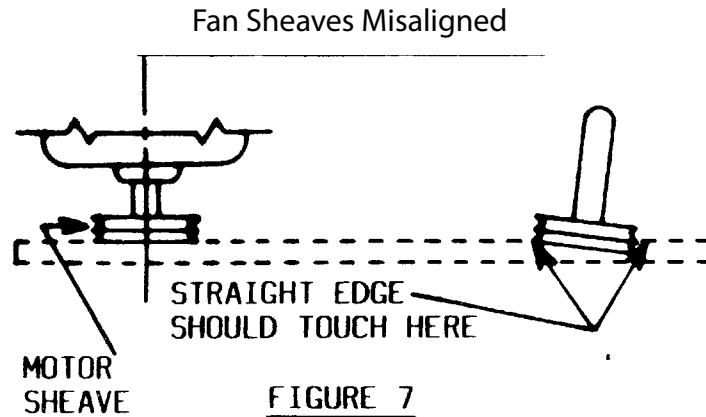

Belt Adjustment

Measure the belt span, (see image). Using a spring scale, apply a perpendicular force to any one of the belts at the mid point of the span. Measure the force required to deflect any one of the belts 1/64" (.40mm) for every inch (25mm) of span length. For example, the deflection for a 32" (813mm) span would be 1/64" (.40mm) multiplied by 32, or 1/2" (13mm). The force required to deflect the belt is listed in the table below. Initially, tighten the belts to the values listed in column "Run-In Time". There will normally be a drop in tension during the first 24 to 49 hours of operation. During this "run in" period, the belts seat themselves in the sheave grooves and the initial stretch is removed. After a day or two, the drive should be stopped and another check made for the correct amount of tension. The tension should now compare with the values in column "Normal Time". If the force is below the level in column "Normal Time". The belts are too loose. If the force is greater than the high level, the belts are too tight. Readjust so that the deflection force is between the high and low value in column "Normal Time".

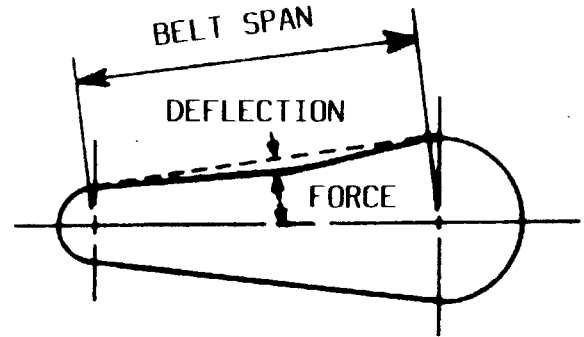

CONVENTIONAL BELT DEFLECTION FORCE

BELT	SMALL DIAMETER RANGE		PRIME MOVER BELTS			
			RUN-IN TIME		NORMAL TIME	
	Inches	mm	lbs.	kg.	lbs.	kg.
A	3.0 - 3.6	76 - 91	4-1/2	9.9	3	6.6
	3.8 - 4.8	97 - 122	5-1/4	11.6	3-1/2	7.7
	5.0 - 7.0	127 - 178	6-1/2	14.3	4-1/4	9.4
B	3.4 - 4.2	86 - 107	6-1/2	14.3	4-1/4	9.4
	4.4 - 5.6	112 - 142	8-1/4	18.2	5-1/2	12.1
	5.8 - 8.6	147 - 218	10-1/2	23.1	7	15.4

Troubleshooting Guide

PROBLEM	PROBABLE CAUSE	SOLUTION
Unit not exhausting properly	<ul style="list-style-type: none"> a) Belts slipping or broken. b) Fire damper shut. Check ecology unit and exhaust hood. c) Plugged filter. d) Exhaust fan motor off on overload. e) Duct work or air outlet blocked. 	<ul style="list-style-type: none"> a) Tighten or replace belts. b) Replace fusible link or holding wire. Check cause. c) Replace filter. . d) Reset and check amperage draw e) Remove obstruction.
No make-up air	<ul style="list-style-type: none"> a) Loose damper linkage causing both dampers to close. b) Loose or broken fan belts. c) Plugged air filter. d) Supply fan motor off on overload. e) Separate supply air system not operating. 	<ul style="list-style-type: none"> a) Tighten and reset linkage b) Tighten or replace belts. c) Replace filters. d) Reset and check amperage draw. e) Recommend to owner to have system serviced.
Unit will not start	<ul style="list-style-type: none"> a) No power. b) Fuses blown. c) Off on overload heater in magnetic starter. d) 120 volt control transformer fuse. e) Blown 5 amp. fuse in exhaust hood wash control panel. f) Defective exhaust fan motor. g) Fan switch on PolluStop control panel in "OFF" position. h) Control switch on exhaust hood panel in "WASH" position 	<ul style="list-style-type: none"> a) Check power supply. b) Replace fuse, check for cause of blown fuse. c) Reset overload and take amperage reading to be sure motor is not overloaded. A blown fuse can cause an overload to trip. d) Replace fuse; if blown, check for cause in 120 volt circuit incl. exhaust hood wash control panel. e) Replace fuse. Check for cause in detergent pump or solenoid coils. f) Replace motor. Check for cause bearings, alignment, motor burn out. Check overload settings with name plate. g) Turn to "ON" position. h) Turn to "RUN" position

Troubleshooting Guide

PROBLEM	PROBABLE CAUSE	SOLUTION
Filter alarms triggering	<ul style="list-style-type: none"> a) Plugged filter. b) Broken pressure switch air tube. c) Loose pressure switch fitting. d) Condensation in pressure switch tubing. 	<ul style="list-style-type: none"> a) Check filter. Replace if required What setting did it alarm at? Adjust pressure switch if required. b) Repair break. Check for cause of break. c) Tighten fitting. d) Blow out condensation from air tube. For outdoor installation check to see if heat wire is installed and operating. If not installed, recommend to the owner that it be installed.
Unit starts, then shuts down	<ul style="list-style-type: none"> a) Filter not seated properly b) Broken or loose pressure switch air tube. c) Exhaust fan belt slipping (not moving enough air). d) Timer not set correctly. e) Defective timer. f) Off on overload heaters. g) Overall pressure switch #4 not set properly. 	<ul style="list-style-type: none"> a) Seat filters. b) Repair break or tighten fitting. c) Tighten or replace fan belts. d) Set time for 60 seconds. e) Replace timer. If burnt out it will have burn mark on top right side. f) Check, reset and check amperage draw. g) Adjust pressure switch setting.
No odor control and/or spraying action	<ul style="list-style-type: none"> a) No power to compressor b) No fluid from nozzle. c) Compressor too hot. d) Supply tube not connected/ loose or cracked. 	<ul style="list-style-type: none"> a) Check power to Compressor. b) Check condition of orifice, check condition of liquid supply. c) Check amperage, verify spray time setting. Check for adequate venting. d) Re-connect tube or replace.

1.

Warranty Activation Form

This form must be completed and returned to Halton in order for your warranty to be valid.

Job & Location Information:

Job Name: _____

Street Name: _____

City: _____ State: _____ Zip Code: _____

Equipment Start-Up Date: _____ Product Serial Numbers: _____

Contact Information:

Contact Name: _____

Title: _____

Chef, Kitchen Mgr/Facility Mgr/Property Mgr/etc.

Facility Management Company Name (if applicable): _____

Email: _____

Phone Number: _____ Cell Number: _____

Fax completed form to:
Halton Company
Attention: Service Department
Fax: (270) 237-5700

Halton Indoor Climate Systems
Attention: Service Department
Fax: (905) 624-5547

Halton Limited Warranty

Halton ("Manufacturer"). Warrants only to its direct purchasers and to no others, that all products manufactured by the Manufacturer shall be free from defect in materials and workmanship for a period of twelve (12) months from the date of the original installation and start-up or eighteen (18) months from date of shipment, whichever occurs first. All products sold but not manufactured by Manufacturer will be warranted for a period of twelve (12) months from date of shipment. (Halton's Warranty Card must be completely filled out and returned to Halton within 3 weeks after the equipment start-up date for your warranty to be valid *IMPORTANT NOTE: "IF" this form is returned within the specified time frame, Halton will extend your standard warranty by 120 days.)

For products manufactured by the Manufacturer we agree to pay any reasonable labor costs necessary to repair or replace, at Manufacturers option, defective parts or materials for a period of twelve (12) months from date of original installation and start-up or eighteen (18) months from date of shipment, whichever occurs first. All labor costs subject hereto shall be performed during standard work hours at straight-time rates.

For products sold but not manufactured by the Manufacturer we agree to pay any reasonable labor costs necessary to repair or replace, at Manufacturers option, defective parts or materials for a period of (90) days from date of original installation and start-up or (12) months from date of shipment, whichever occurs first. All labor costs subject hereto shall be performed during standard work hours at straight time rates.

All warranty claims that include labor requires pre-approval by Halton. Halton, at its discretion, will authorize field warranty work through its own service network or certified third party. No claims for labor charges will be approved for payment if work commences without prior authorization by Halton.

Purchaser shall pay incurred premium labor charge, including overtime, weekends and holidays. Travel time, service charges, miscellaneous tools, material charges, and labor charges resulting from inaccessibility of equipment will not be paid by Manufacturer.

This LIMITED WARRANTY SHALL APPLY ONLY to products that have been installed and maintained in accordance with the installation and Care Instruction Manuals. Purchaser shall be solely responsible for adhering to the instructions and procedures set forth in the said instruction manuals.

Only Halton replacement filters should be used in this product. Using non Halton filters will void this warranty.

This LIMITED WARRANTY SHALL NOT BE APPLICABLE to any damage or defect resulting from fire, flood, freezing or any Act of God, abuse, misuse, accident, neglect or failure to adhere to all instructions set forth in the installation and Care Instruction Manuals. Furthermore, this limited warranty shall not apply to any product that has been altered, unless such alteration has been approved in writing by a duly authorized representative of the manufacturer. In no event shall the manufacturer be liable for any loss, expense, personal injury or consequential damage, of any kind or character, as may result from a defect in material, and/or workmanship, however caused.

EXCEPT AS IS EXPRESSLY SET FORTH IN THIS LIMITED WARRANTY, MANUFACTURER MAKES NO WARRANTY OF MARKETABILITY FOR FITNESS OR ANY PARTICULAR PURPOSE. NEITHER DOES MANUFACTURER MAKE ANY WARRANTY, EXPRESSED OR IMPLIED, WITH RESPECT TO PRODUCTS SOLD BY MANUFACTURER OR AS TO THE USE THEREOF.

Continuous product improvement is a Halton policy, therefore specifications and design are subject to change without notice.