

Operators Manual for Halton SafeGuard

Manual provides System Overview,
Installation, Operation, and Maintenance Instructions



Halton SafeGuard is an IoT (Internet of Things) based Ecosystem of kitchen ventilation

Halton

Table of Contents

Safety Information	4
Specific Safety Precautions	5
Halton SafeGuard	8
M.A.R.V.E.L. System Overview	9
General Description	9
M.A.R.V.E.L. System Components	11
Overview	11
Components	12
M.A.R.V.E.L. Sequence of Operations	15
Overview	15
Sequence of Operations	15
M.A.R.V.E.L. Plus VAV Operation	17
Introduction	17
VAV - Kitchen Variable Air Volume Terminal Unit	18
SafeGuard Touch Screen Operation	19
Individual Hood Selection Screen	19
Individual Hood Selection Screen, continued	20
Alarm History Screen	21
Halton AirWatch Screen	22
Halton FireWatch Screens	22
Scheduler Screen	24
M.A.R.V.E.L. System Operation	25
M.A.R.V.E.L. System Installation	26
Halton FireWatch	30
General Description	30
FireWatch Components	32
Wiring of the HCL lights with central HCL light with Red Alarm function	36

M.A.R.V.E.L. System Maintenance	37
General	37
Thermal Imaging Sensor Cleaning	37
Temperature Sensor Removal/Replacement	38
Balancing Damper Actuator Removal/Replacement	39
Pressure Transducer Removal/Replacement	40
Balancing Damper Actuator Removal/Replacement - Belimo	41
M.A.R.V.E.L. System Monitoring and Support	47
Types of Monitoring	47
KONTAR-Konsole™ Software	47
FAQ's (Frequently Asked Questions)	47
M.A.R.V.E.L. Parts List	47
Contact Information	48
Warranty Form	49
Halton Limited Warranty	50

Safety Information

The instructions contained in this manual have been prepared to aid you in learning the proper procedures for installing and servicing your unit.

Throughout this manual, safety precautions are identified through the use of the safety alert symbol and three signal words: DANGER, WARNING, and CAUTION. All safety alert information precedes the step(s) to which they apply. Suggested, recommended, or other noteworthy information is identified through the use of NOTES. Additionally, certain words are used to indicate a specific meaning or to add emphasis.

The following words are used as indicated throughout the manual:

Shall: understood to be mandatory.

Should: understood to be advisory.

May: understood to be permissive.

Will: indicates a future event/condition to occur.



(Safety Alert Symbol)

Used in conjunction with signal words (DANGER, WARNING, or CAUTION) to alert you of potential personal injury hazards, immediately preceding precautionary measures that pertain to subsequent step(s). Obey all safety messages that follow this symbol to avoid possible injury or death. Failure to adhere to safety precautions identified by the safety alert symbol may also void the warranty.



- Indicates an imminently hazardous situation which, if not avoided, will result in death or serious injury. Use of this is limited to the most extreme situations.



- Indicates a potentially hazardous situation which, if not avoided, could result in death or serious injury.



- Indicates a potentially hazardous situation which, if not avoided, may result in minor or moderate injury. Also used to alert against unsafe practices.



- When used without the safety alert symbol, CAUTION indicates a potentially hazardous situation which, if not avoided, may result in equipment/property damage, and void the warranty.

NOTE:

- Identifies suggested, recommended, or other noteworthy information.

Specific Safety Precautions

For your safety, please observe the following precautions when operating or servicing your (Insert Name and Model of Hood here). Read the following important safety information to avoid personal injury and/or damage to the equipment.

DANGER

- Always disconnect the source of the main power before removing the service entrance box cover.
- Failure to ensure the Power switch is in the “OFF” position during servicing and when replacing filters could result in equipment damage, electrical shock and/or personal injury.
- Failure to comply with these DANGER notices will result in death or serious injury, equipment/property damage, and void the warranty.

WARNING

- DO NOT use or store flammable liquids or materials that produce flammable vapors in the vicinity of this or any other appliance!
- Consult a qualified electrician to ensure all electrical specifications have been met and the unit is properly grounded.
- Before installing or servicing this equipment, read the contents of this manual thoroughly.
- Improper installation, adjustment, alteration, service or maintenance could result in death or serious injury, equipment/property damage, and void the warranty.
- Failure to comply with these WARNING notices could result in death or serious injury and equipment or property damage.

WARNING

- Internal ultraviolet radiation source present.
- Keep protective barrier in place.
- Replace all removable parts after servicing.
- An interlock is in place to reduce the potential of exposure to excessive ultraviolet radiation. DO NOT attempt defeat or bypass this interlock system.

CAUTION

- Exercise care when removing the wooden crating from around the unit.

CAUTION

- DO NOT operate the unit unless you fully understand the components and their intended function.
- Failure to comply with these CAUTION notices may result in minor or moderate injury, equipment or property damage, and void the warranty.

CAUTION

- The electronic components of the Control Panel are impact-sensitive. Exercise care around the Control Panel to maintain proper operation.
- During cleaning of Hood.
 - DO NOT use products containing chlorine.
 - DO NOT use abrasive products, steel wool or scouring pads.
- Failure to comply with these CAUTION notices may result in equipment/property damage and void the warranty.

NOTE:

- If upon receipt, the palletized unit shows any signs of damaged, immediately inspect the entire Hood and the included accessories, and promptly notify the freight company of any damages.
- To aid the electrician, an electrical wiring diagram is included with this manual. Refer to the wiring diagram during installation or servicing. A wiring diagram may be obtained from the factory by calling Halton at 270-236-5600
- Comply with all appropriate state and/or local health regulations regarding the cleaning and sanitation of equipment.
- For difficult areas with excessive particulate build up, a mild bio-degradable non-toxic degreaser (such as Clear Magic or Simple Green) may be used.
- Always ensure the unit is electrically grounded and installed in accordance with local codes, or in the absence of local codes, in accordance with the National Electrical Code ANSI/NFPA No. 70-1984.

NOTE:

- An HVAC specialist may be required for some installations to confirm proper air exchange and the heat load capabilities of the on-site AC system.



- Use suitable equipment to lift the hood and carefully move it away from the pallet. Take precautions not to damage to the hood. If possible, it is advisable to rig and lift the hood from the topside, utilizing the hood's hanging brackets.
- Exercise care when removing the wooden framing from around the unit.
- Failure to comply with these CAUTION notices may result in minor or moderate injury, equipment or property damage, and void the warranty.



- DO NOT MODIFY, ALTER OR ADD ATTACHMENTS TO THIS EQUIPMENT

General Systems Information

To achieve the optimum performance from your hood system(s) please use the following guidelines provided within the pages of this Operation, Maintenance and Service Manual.

In addition to this information technical support is available from the Halton Factory during regular office hours, 7 A.M. to 5 P.M. Central Time, to provide support for products, applications, installation, commissioning or for any aspect that you may have. Our local sales representatives can also provide support.

Recommendation

Upon receipt of the Halton hood(s), inspect unit(s) immediately for any shipping damage and notify carrier immediately if damage is found. Halton will not accept responsibility for any shipping damage. All systems are thoroughly inspected before leaving our factories; however Halton will assist in filing a claim if needed.

General Installation

It is the responsibility of the installing contractor to see that the system installation is completed in accordance with the project plans and specifications and that it meets all specific requirements of local code officials. The local authority having jurisdiction could over rule some of the installation details written in this manual. The installation shall be in accordance with NFPA-96. All electrical systems shall be installed following local and national codes.

The owner and/or operator should be instructed in the proper operation, care and maintenance of the system.

If questions or complications should arise during the installation of the Halton hood (s) that cannot be solved using the instructions provided please contact the Halton office at 1-800-442-5866, or (1-800-4-HALTON).

Halton SafeGuard

Halton SafeGuard is an IoT based Ecosystem of kitchen ventilation based solutions to optimize performance, reduce energy consumption, predict maintenance, improve indoor environmental quality and mitigate fire risk.

- M.A.R.V.E.L. Variable volume operation based on heat signature of appliances
- Control of common exhaust fan for minimum energy consumption at all times
- Automatic balancing dampers
- Direct appliance communication (where available)
- Early fire warning signals
- Internet monitoring and programming

Halton SafeGuard Unique Design

Starting with the Halton extensive product line of commercial foodservice ventilation solutions, M.A.R.V.E.L. adds the following unique components:

- THERMAL IMAGING SENSOR, measures cooking surface temperature and rate of change in temperature to determine cooking status in conjunction with duct collar and space temperature sensors
- Halton AirWatch sensors to monitor indoor environmental quality
- Halton FireWatch, 24/7 electronic fire warning system with data backup

M.A.R.V.E.L. System Overview

General Description

Halton's M.A.R.V.E.L. (Model based Automated Regulation of Ventilation Exhaust Levels) system offers a demand control ventilation (DCV) solution. M.A.R.V.E.L. builds upon the existing Halton product line, such as the Capture Jet™ technology, to deliver a product that reduces energy costs by scheduling and adjusting exhaust airflow based on hours of operation and appliance use. +

Halton's M.A.R.V.E.L. delivers:

- Hood exhaust airflow adjustment depending on cooking activities
- Control of common exhaust fan for minimum energy consumption at all times
- Automatic balancing dampers
- Direct appliance communication (where available)
- Early fire warning signals
- Internet monitoring and programming

Halton SafeGuard Unique Design

Starting with the Halton extensive product line of commercial foodservice ventilation solutions, M.A.R.V.E.L. adds the following four unique components:

Thermal Imaging Sensor: THERMAL IMAGING SENSOR, measures cooking surface temperature and rate of change in temperature to determine cooking status in conjunction with duct collar and space temperature sensors

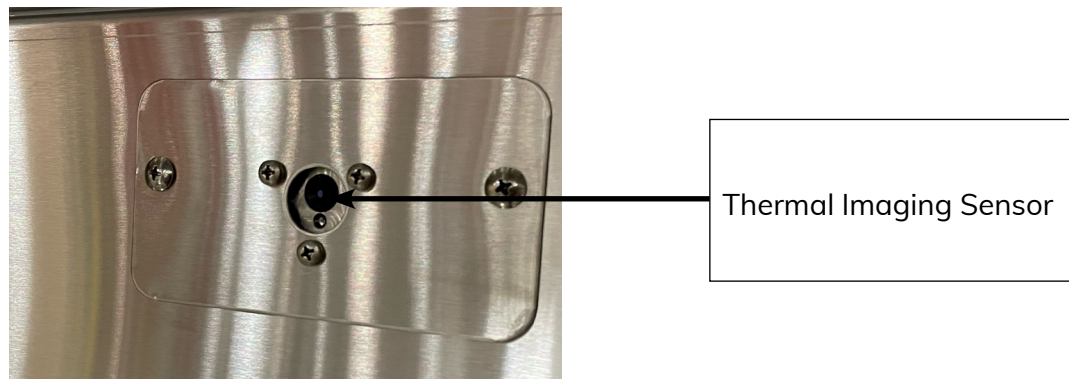

Distech Controller: The heart of the system, the controller features 22 inputs/outputs and is designed to collect real time information and to implement various automation control algorithms. The Distech Controller responds to the Thermal Imaging Sensor(s) and duct temperature sensor to measure changes in cooking status.

Example:



Differential Pressure Transducer: Used in conjunction with the value from the temperature sensor and Thermal Imaging Sensor(s) to measure and control the airflow thru each hood.

Duct Temperature Sensor: Located in the hood collar, the temperature sensor is used in conjunction with the pressure transducer value and Thermal Imaging Sensor to control the airflow.

Halton AirWatch Sensor: An Indoor Environmental Quality Sensor Mounted on a kitchen wall close to a thermostat. Connections: to the control panel with 4 wires.

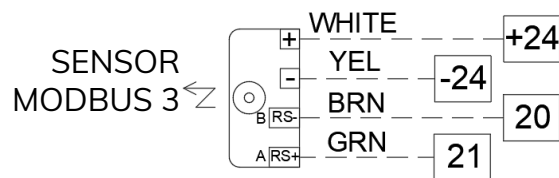

Halton AirWatch Sensor Typical Wiring Diagram

Halton FireWatch: 24/7 electronic fire warning system with data backup

M.A.R.V.E.L. System Components

Overview

A key feature of the M.A.R.V.E.L. system is flexibility. It can be applied to a single hood – or over multiple hoods – depending on the requirements.



Figure 1: Single Hood M.A.R.V.E.L. Installation



Figure 2: Multiple Hood M.A.R.V.E.L. Installation

Components

NOTE: Refer to Figure 1+2

Equipment	Description	Power + Connection Details
Thermal Imaging Sensor	<ul style="list-style-type: none"> Thermal Imaging Sensor covers hoods up to 14 feet in length. Longer hoods will receive two Thermal Imaging Sensors. 	<p>Power source: 5 volt DC power supply located behind a cover on the Capture Jet™ plenum.</p> <p>Connection: at terminal block located behind a cover on the Capture Jet™ plenum.</p>
TS Duct temperature sensor	<ul style="list-style-type: none"> Measures the temperature of the exhaust air. Located in the hood collar. Used (in conjunction with the Thermal Imaging Sensor) to detect the event of cooking equipment start-up. <p>Duct temperature is often a better indicator of appliance start-up in the case of certain types of equipment such as a gas fryer.</p> <ul style="list-style-type: none"> Used to activate the early fire detection alarm, activated before the fire system is triggered. 	<p>Connection: at terminal block located behind a cover on the Capture Jet™ plenum.</p>

Equipment	Description	Power + Connection Details
PT (Pressure Transducer) Hood plenum pressure sensor	<ul style="list-style-type: none"> Used to calculate air flow in a hood in real time. 	<p>Power source: 24 V DC power supply located behind a cover on the Capture Jet™ plenum.</p> <p>Connection: at terminal block located behind a cover on the Capture Jet™ plenum.</p>
ABD Automatic Balancing Damper	<p><i>NOTE:</i> For multiple hood installations with a single exhaust fan only</p> <ul style="list-style-type: none"> Adjusts air flow with motorized balancing dampers attached to a collar at each hood. Damper controlled by a 0-10 V DC position reference signal generated by a controller. Upon power failure, the automatic balancing damper fully opens. 	<p>Power source: 24 V AC transformer located behind a cover on the Capture Jet™ plenum</p> <p>Connection: at terminal block located behind a cover on the Capture Jet™ plenum</p>
Alarm light status on a touch screen	<ul style="list-style-type: none"> Activated when any alarm condition is detected. Common alarm conditions include: filter missing, filter clogged, fire suppression system activated, duct temperature dangerously high, sensor failed, or VFD is in fault. <p><i>NOTE:</i> To easily diagnose the alarm, use the remote Konsole™ Diagnostic Software.</p>	
Override push button	<ul style="list-style-type: none"> Used to override pre programmed operation, push button illuminated when activated. Two modes: <ol style="list-style-type: none"> Press and hold for 1 second to accelerate the exhaust rate to 100% of the design air flow for a pre programmed period of time (default 5 minutes.) Press and hold for 3 seconds to accelerate the exhaust rate to 100% of the design air flow for a pre programmed period of time (default 1 hour.) Starts the hood if it has been overridden by a schedule or an 'off' state. 	<p>Connection: at terminal block located behind a cover on the Capture Jet™ plenum.</p>
Halton AirWatch sensor	<ul style="list-style-type: none"> Mounted on a kitchen wall close to a thermostat. 	<p>Connections: to the control panel with 4 wires</p>
VFD Variable Frequency Drive	<ul style="list-style-type: none"> Controls the speed of a three-phase fan motor by changing the frequency of the current to the motor. For smaller fans, mount the VFD in a cabinet attached to a hood. For larger exhaust fan units, attach the VFDs to a fan unit or cabinet or mount remotely. 	<p>Power source: varies as per fan's voltage requirement</p> <p>Connection: at terminal block in VFD control panel to main control panel</p> <p>Speed reference: 0-10 VDC</p>

Equipment	Description	Power + Connection Details
CP Control Panel	<ul style="list-style-type: none"> Mounted on top of each hood with access from the bottom. <p><i>NOTE:</i> For multiple units with a single fan, a separate control panel (see below) is also required.</p> <ul style="list-style-type: none"> Provides permanent Ethernet connection (optional). Provides temporary Ethernet connection for service. Provides USB B Serial connection for on-site service 	Power source: 120 VAC, 5 amp. fuse, grounded
Central control panel (for multiple units with single fan)	<ul style="list-style-type: none"> Separate control panel mounted at a convenient location to link that individual control panels on the hoods with the VFD controller. 	Power source: 120 VAC, 5 amp. fuse, grounded

CAUTION

Safety

Only authorized personnel should have access to the control panel.

In case of occurrence of any problem please call an authorized agency to help you.

! WARNING

Warnings

- To reduce risk of electric shock do not expose control panel to any water.
- Disconnect the power from the mains before accessing the control panel.
- To provide protection against electric shock connect to a properly grounded power supply.
- Improper grounding can result in a risk of electric shock.
- Consult a qualified electrician if the grounding instructions are not properly understood, or if any doubt exists as to whether the control panel is properly grounded.
- Only authorized and qualified personnel should work on the control panel in event of a problem.

M.A.R.V.E.L. Sequence of Operations

Overview

A sequence of operations is a series of steps required to perform a given task. The DCV system uses the following sequence of operations to control the exhaust hood operation.

Sequence of Operations

Startup & Shutdown

Operation Step	Details
Startup	<ul style="list-style-type: none"> • Turns exhaust system on. • Can be started by: <ul style="list-style-type: none"> • 24/7 pre-programmed schedule. • The building management system or via an internet connection remotely • Reaching a pre-determined Thermal Imaging Sensor parameter or duct temperature level. • Pressing the override button. • After startup, enters Idle mode. • Minimum Run Time A hood that becomes active will always run the exhaust fan for a minimum of 15 minutes before shutting the exhaust fan down. This is done prevent the possibility of an exhaust fan being forced to start and stop frequently.
Shutdown	<ul style="list-style-type: none"> • Turns system off. • Can be shutdown by any of the parameters listed in the Startup step (above) except the override button.
Idle Mode	<ul style="list-style-type: none"> • System starts up in Idle mode (after startup). • Pending until signs of cooking activity sensed from Thermal Imaging Sensor. • Minimal exhaust flow captures any appliance-generated heat. Default is 40% of design air flow or as adjusted to meet requirements. • After idle mode, enters Cooking.
Vent Mode	<ul style="list-style-type: none"> • Vent Mode is enabled when a hood or hoods are in Cook Mode and the design exhaust airflow of that hood(s) does not reach the minimum turn down of the system's exhaust fan. • In Vent Mode previously designated Relief Hoods' dampers will open to allow the exhaust fan to operate at its minimum turn down rate to avoid damage to the fan motor. • The relief hood(s) exhaust airflow will make up the difference between the active hood exhaust cfm and the cfm required to meet the exhaust fan's minimum turn down set point.
Cooking Mode	<ul style="list-style-type: none"> • System moves into cooking mode when a Thermal Imaging Sensor detects cooking activities under the hood. • Exhaust fan speed increased to design air flow and balancing dampers (if present) adjusts the airflow in the hood to design level to assure sufficient capture and containment. • Air flow in the hood is maintained for a predetermined cooking time before returning to the Idle mode. <p>NOTE: If during this time more cooking activities are detected, the cooking timer will be restarted and design exhaust airflow maintained.</p>

Operation Step	Details
Override Mode	<ul style="list-style-type: none"> • Used to override pre programmed operation. • Two modes: <ol style="list-style-type: none"> 1. Press and hold for 1 second to accelerate the exhaust rate to 100% of the design air flow for a pre programmed period of time (default 5 minutes). 2. Press and hold for 3 seconds to accelerate the exhaust rate to 100% of the design air flow for a pre programmed period of time (default 1 hour.) Starts the hood if it has been overridden by a schedule or an 'off' state.
FireWatch Mode	<p>Stage 1 – Visual warning is initiated - Flashing HCL light in hood, or strobe light, and text warning on touch screen. Intervention by the kitchen staff should take place immediately to lower temperatures at appliances to prevent a potential fire. If action is not taken, system may proceed to Stage 2 - AN APPLIANCE FIRE IS HIGHLY LIKELY AT THIS POINT!</p> <p>Stage 2 – Visual warnings and audible warnings are initiated - Flashing HCL light in hood, or strobe light, text warning on touch screen and also buzzer at touch screen if the situation has not been addressed. Intervention should take place by the kitchen staff at this point to prevent a fully involved appliance fire and fire suppression system discharge. Equipment should be manually turned off or, if equipped with the optional FireWatch Equipment Shut Down feature, the system will automatically shut off all equipment</p>
Fire Mode	<ul style="list-style-type: none"> • If a fire signal is detected by the Fire Suppression system in the kitchen, the system triggers a fire alarm and stops the make-up air fan. • The exhaust fan will either stop or continue running depending on the local fire code requirements.
Halton AirWatch	<p>The system calculates and air quality index based on the following parameters:</p> <p>Particulate Matter (PM), Volatile Organic Compounds (VOC's)</p> <p>If the index is too high, the system will increase exhaust airflows. Additionally, the system is monitoring the CO2 in the kitchen and if those levels get too high, the exhaust airflows (and corresponding MUA) will also increase up to design airflows.</p>
Off Mode	<ul style="list-style-type: none"> • Exhaust and make-up air fans stop when no appliances are operating (e.g., turned off and cooled down).
Airflow Reporting and Replacement Air Control	<ul style="list-style-type: none"> • System continuously monitors exhaust airflow at each hood and generates a signal 0 to 10 V proportional to total exhaust airflow as fraction of total design. 0 V - system is off; 7 V - system operates at 70% of design airflow, etc. This signal is used to control Replacement air to maintain building pressurization.
Alarm and Fault Conditions	<ul style="list-style-type: none"> • System constantly monitors various parameters. If any unusual or abnormal condition is detected, an alarm is activated. • An alarm indicator can include: • Indication on HMI (Touch Screen). • Email or text message sent to a computer or a mobile device, pager, visual display on a computer screen or through a SCADA interface.

M.A.R.V.E.L. Plus VAV (Variable Airflow Volume) Operation

Introduction

Halton's self-balancing kitchen (also referred to as MARVEL+) provides regulated exhaust and supply airflows to specified kitchen zones. The system works with the MARVEL 1 or MARVEL 2 platform to vary both the exhaust and supply airflows based on the status of the cooking appliances underneath the hood(s).

Zones can be defined either by exhaust fan group, room or usage schedule depending upon application.

The VAV boxes used in the M.A.R.V.E.L.+ system are used to control airflow when supply air is being sent to more than one zone, regardless of whether it is in the kitchen or in another building zone.

The M.A.R.V.E.L.+ system will balance each kitchen zone to maintain the desired space balance in the zone.

The airflows for the exhaust hoods and VAV boxes are both measured using pressure transducers and sent to the Distech controllers at the hood. The hood controller will then send a 2-10 Volt signal back to the VAV box to adjust the dampers as needed. If a dedicated makeup unit (MUA) serving kitchen area is used, the system will also control the speed of the supply fan feeding the VAV boxes in order to optimize the energy consumption of the system.

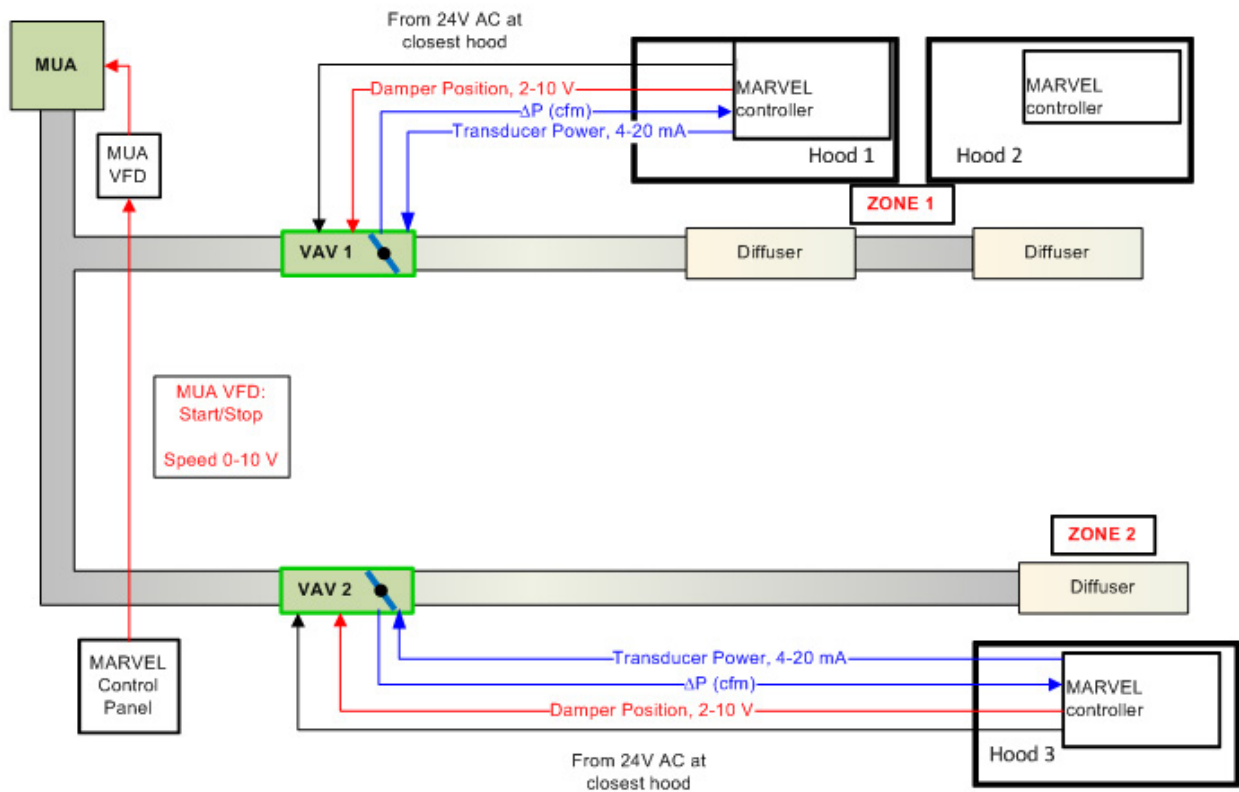

Make Up Air Control Diagram

VAV - Kitchen Variable Air Volume Terminal Unit

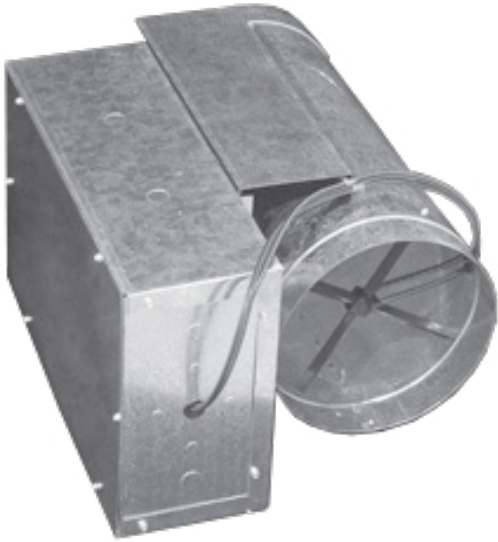

KVV-R

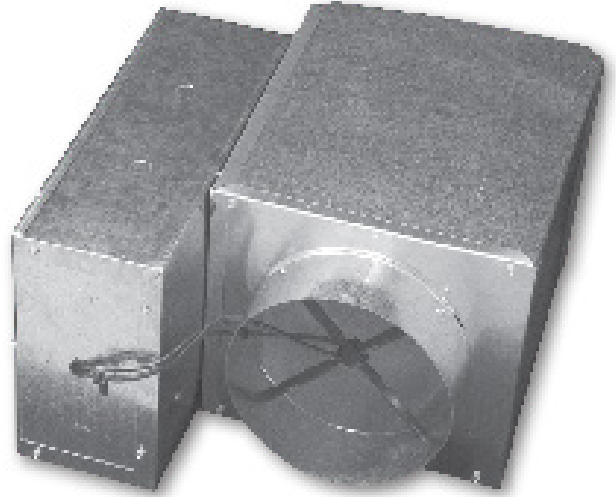

KVV-S

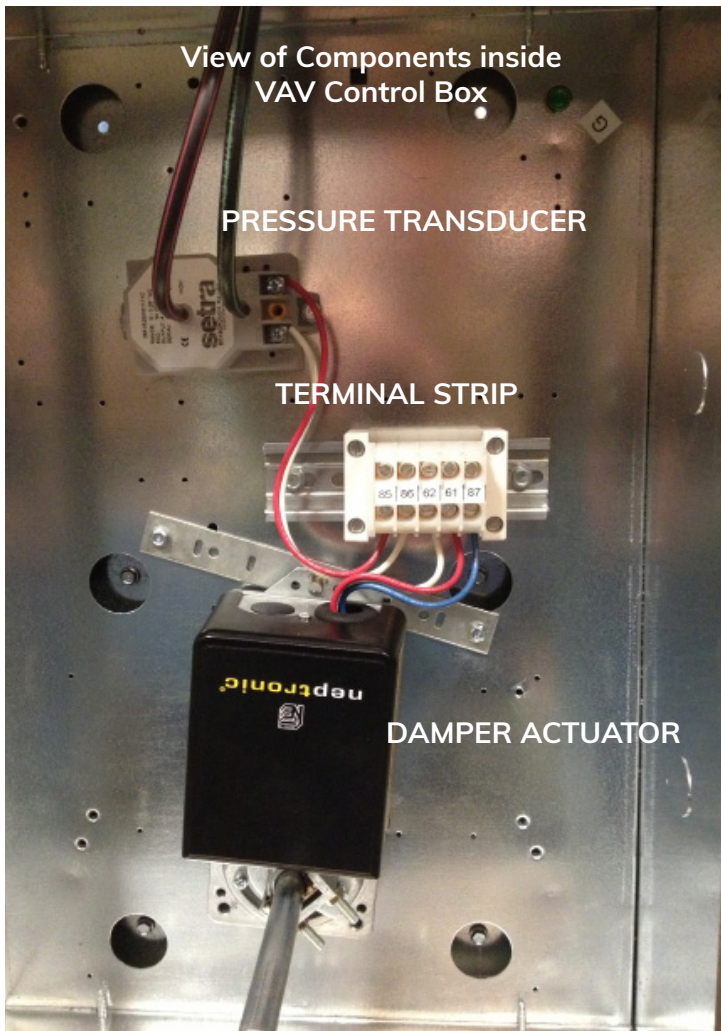

VAV Wiring Diagram

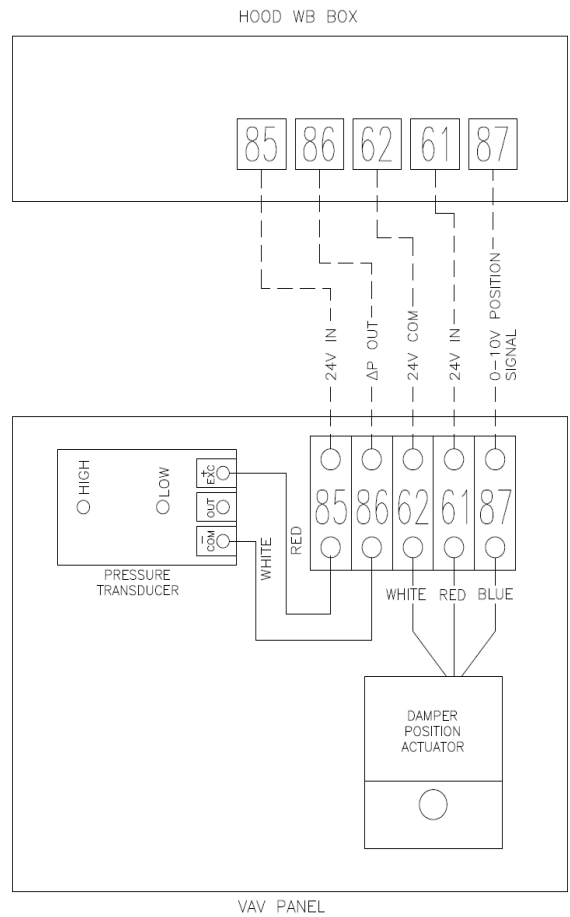

SafeGuard Touch Screen Operation

The central control panel features a user friendly touch screen interface. The following illustrations depict the navigation and features of the touch screen.

Note: Touch screen samples shown below are for the basic M.A.R.V.E.L. system, for all other M.A.R.V.E.L. systems including UV, Water Wash, PolluStop & KGS or combination thereof, please refer to the appropriate manuals for those products.

This touch screen allows the user to scroll the screen up and down to view the entirety of the home page or any of the pages. Certain selections have pull down menus to access different features of the selection.

Home Screen

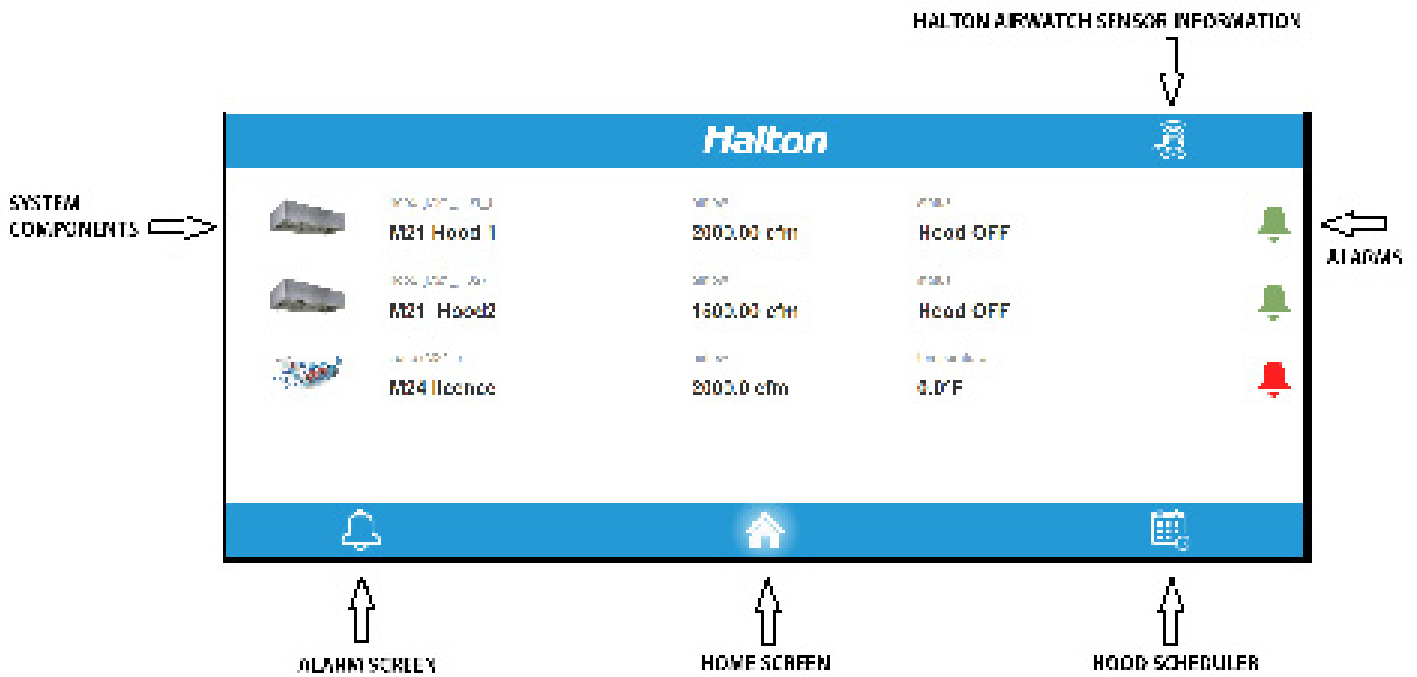

Individual Hood Selection Screen

Select one of the items on the Home screen to view the details about this item. This screen will allow you to drill down into the operation of a specific hood. Once selected you may scroll down for additional information about the hood (next two screen illustrations, below).

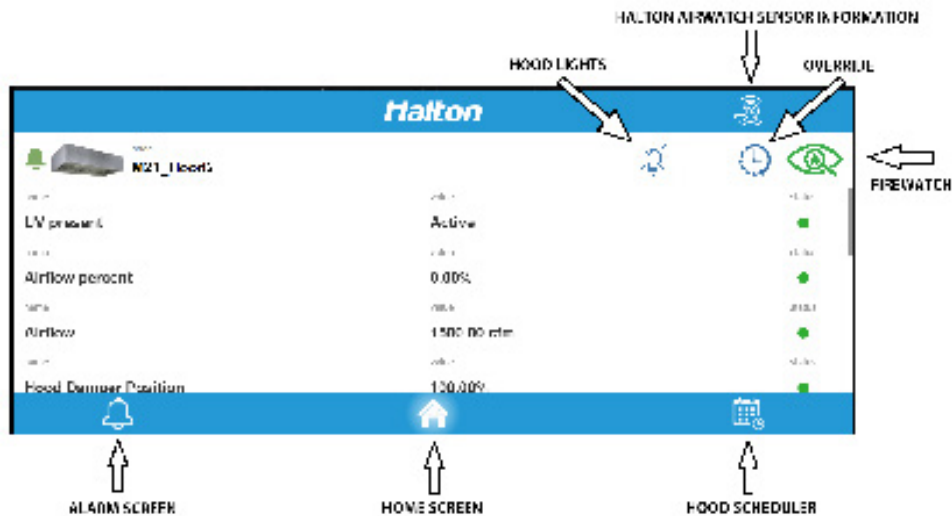

Individual Hood Selection Screen, continued

This screen will allow you to move to your choice of Individual Hood Status screen. Scrolling down will reveal more of the screen.

The screenshot shows the Halton mobile application interface for 'Hood2'. At the top, the 'Halton' logo is on the left and a wireless signal icon is on the right. Below the header, there is a notification bell icon, a hood icon labeled 'hood Hood2', a lightbulb icon, and a magnifying glass icon over a flame. The main content area displays two rows of data:

name	value	status
Duct pressure	0.00 inH ₂ O	●
Duct temperature	0.00°F	●

At the bottom, there is a blue navigation bar with three icons: a notification bell, a home icon, and a calendar icon.

Scrolling down will reveal more of the screen.

This screenshot shows the same Halton mobile application interface for 'Hood2', but with different data displayed. The layout is identical to the previous screenshot, including the header, icons, and navigation bar.

name	value	status
Hood operation status	Hood OFF	●
UV OnOff status	FALSE	●
Design airflow	2000.00 cfm	●

Alarm History Screen

This screen will display your current alarms along with the alarm history.

The screenshot shows the Halton Alarm History Screen. At the top, there is a blue header with the Halton logo and a settings gear icon. Below the header is a red warning banner that reads: "Fire Watch is disabled. Please schedule visit with Halton Service service.us@halton.com to configure and enable this service." Below the banner is a list of four alarms, each with a bell icon, a timestamp, a description, and a document icon with a clock. The bottom of the screen features a blue navigation bar with icons for notifications, home, calendar, and a user profile.

Alarm Status	Time	Date	Description	Action
Red Bell	09:14:34 AM	29 Aug 2022	Hood 1\Duct DP Sensor Fail	Document with Clock
Red Bell	09:07:46 AM	29 Aug 2022	Hood2\Duct DP Sensor Fail	Document with Clock
Green Bell	09:07:44 AM	29 Aug 2022	Hood2\IEQ sensor status	Document with Clock
Green Bell	09:07:02 AM	29 Aug 2022	Hood2\Duct Cleaning Required	Document with Clock

Selecting any of the individual alarms will allow you to see details about that alarm.

This screenshot shows the same Halton Alarm History Screen as above, but with a modal window open over the second alarm. The modal window displays the details for the alarm: "09:07:46 AM 29 Aug 2022 Hood2\Duct DP Sensor Fail". The background list of alarms is dimmed. The bottom navigation bar remains visible.

Alarm Status	Time	Date	Description
Red Bell	09:14:34 AM	29 Aug 2022	Hood 1\Duct DP Sensor Fail
Red Bell	09:07:46 AM	29 Aug 2022	Hood2\Duct DP Sensor Fail
Green Bell	09:07:44 AM	29 Aug 2022	Hood2\IEQ sensor status
Green Bell	09:07:02 AM	29 Aug 2022	Hood2\Duct Cleaning Required

Alarm Status	Time	Date	Description
Red Bell	09:07:46 AM	29 Aug 2022	Hood2\Duct DP Sensor Fail
Green Bell	09:07:43 AM	29 Aug 2022	Hood2\Duct DP Sensor Fail

Halton AirWatch Screen

This screen shows the health and comfort parameters measured by the Halton AirWatch sensor

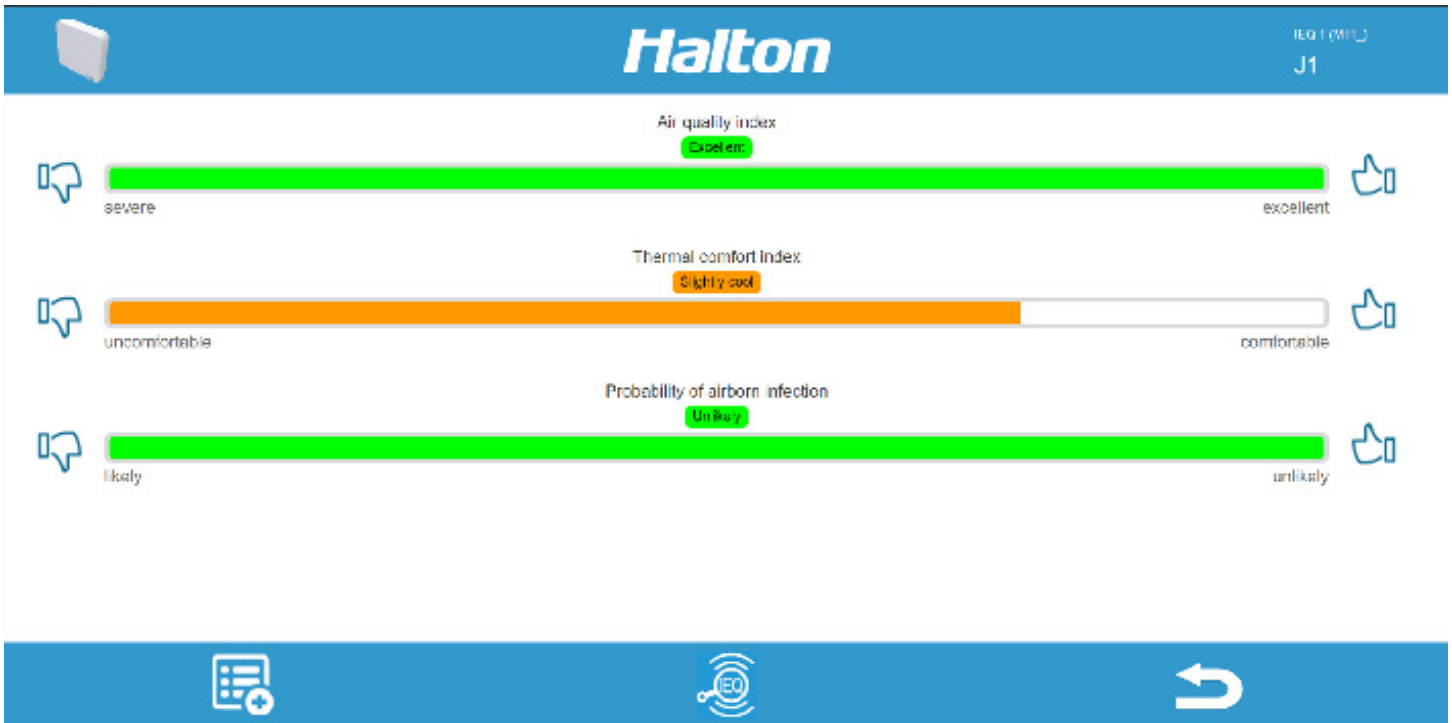

Halton FireWatch Screens

The Halton FireWatch screen displays a table of hood status and airflow data. The table has five rows, each representing a different hood. The columns are: hood name, airflow (cfm), status, and alarm. The alarm column shows a green dot for 'Hood Off' and an orange dot for 'Hood On'.

Hood Name	airflow	status	alarm
hood (M11_) J1	785.00 cfm	Hood Off	Green
hood (M12_) J2	0.00 cfm	Hood On	Green
hood (M23_H01_) J3.01	0.00 cfm	Hood OFF	Green
hood (M23_H02_) J3.02	0.00 cfm	Hood OFF	Green
hood (M22_H01_) J2.01	1345.00 cfm	Hood OFF	Orange



hood J1

name	value	setpoint	status
Airflow	795.00 cfm		
Hood operation status	Hood Off		
Airflow percent	122.00%		
Duct differential pressure	0.38 inH₂O		
Duct temperature	71.46°F		

Navigation bar:

Stage 1 - Warning Screen

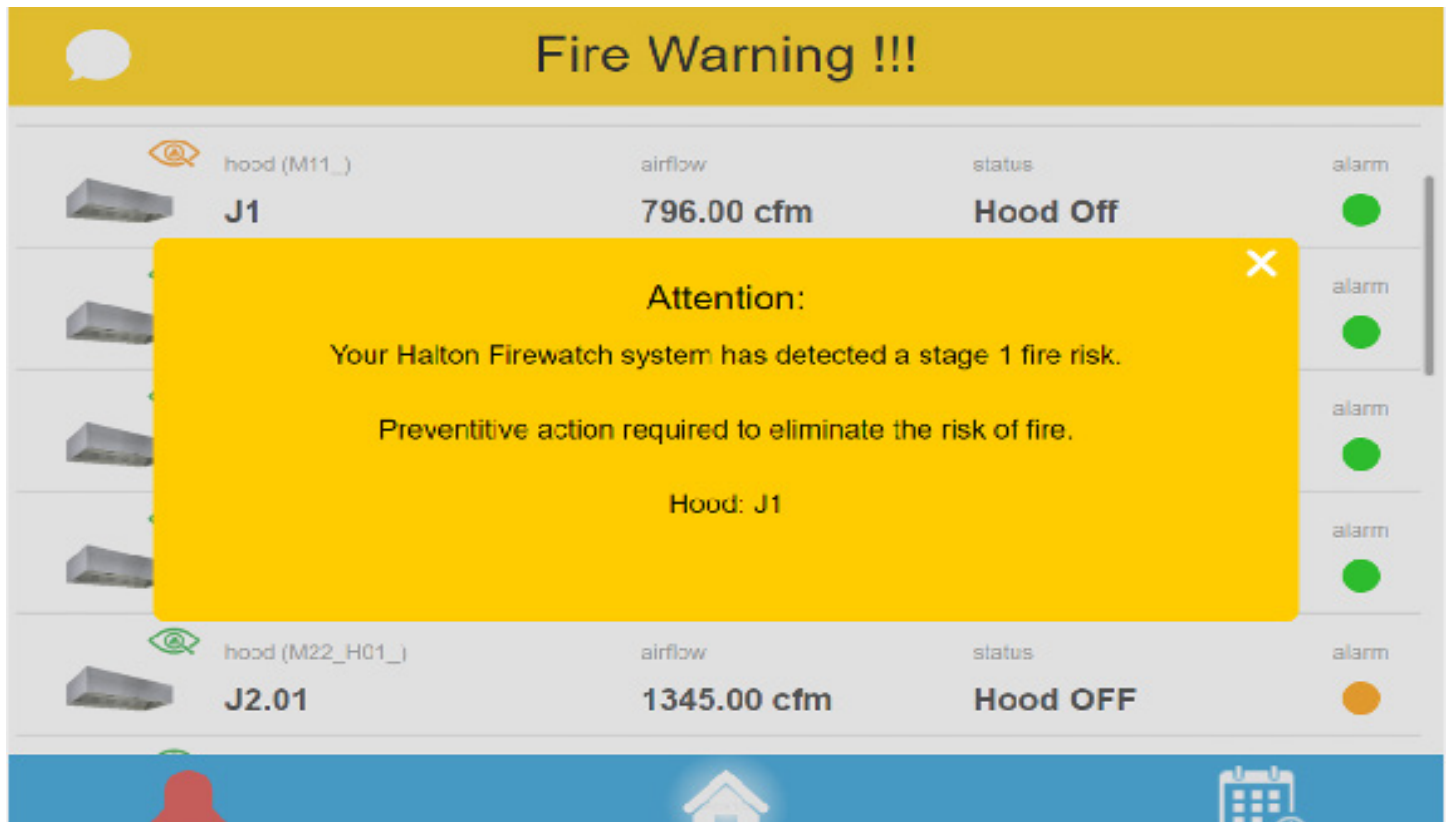

Fire Warning !!!

hood (M11_)	airflow	status	alarm
J1	796.00 cfm	Hood Off	
J2.01	1345.00 cfm	Hood OFF	

Attention:

Your Halton Firewatch system has detected a stage 1 fire risk.

Preventive action required to eliminate the risk of fire.

Hood: J1

Navigation bar:

Stage 2 - Warning Screen

Scheduler Screen

This screen will allow scheduling of the whole system or parts of the system. The operation of the hoods may be set to a schedule. Individual functions, like water wash function, may be scheduled with this screen. Select a function and drag and drop to a day and time to set the schedule.

If you are a Halton Certified Service Agent that requires a password for the screen above, please contact Halton Service Network at 1 (800) 442-5866 (USA) or 1 (800) 565-2981.

M.A.R.V.E.L. System Operation

NOTE: Refer to the Capture Jet™ Hood IO&M Manual for complete details on operating the hoods.

The following steps ONLY apply to the M.A.R.V.E.L. components (Thermal Imaging Sensor, Distech Control Panel, Pressure Transducer and Temperature Sensor).

NORMAL OPERATION

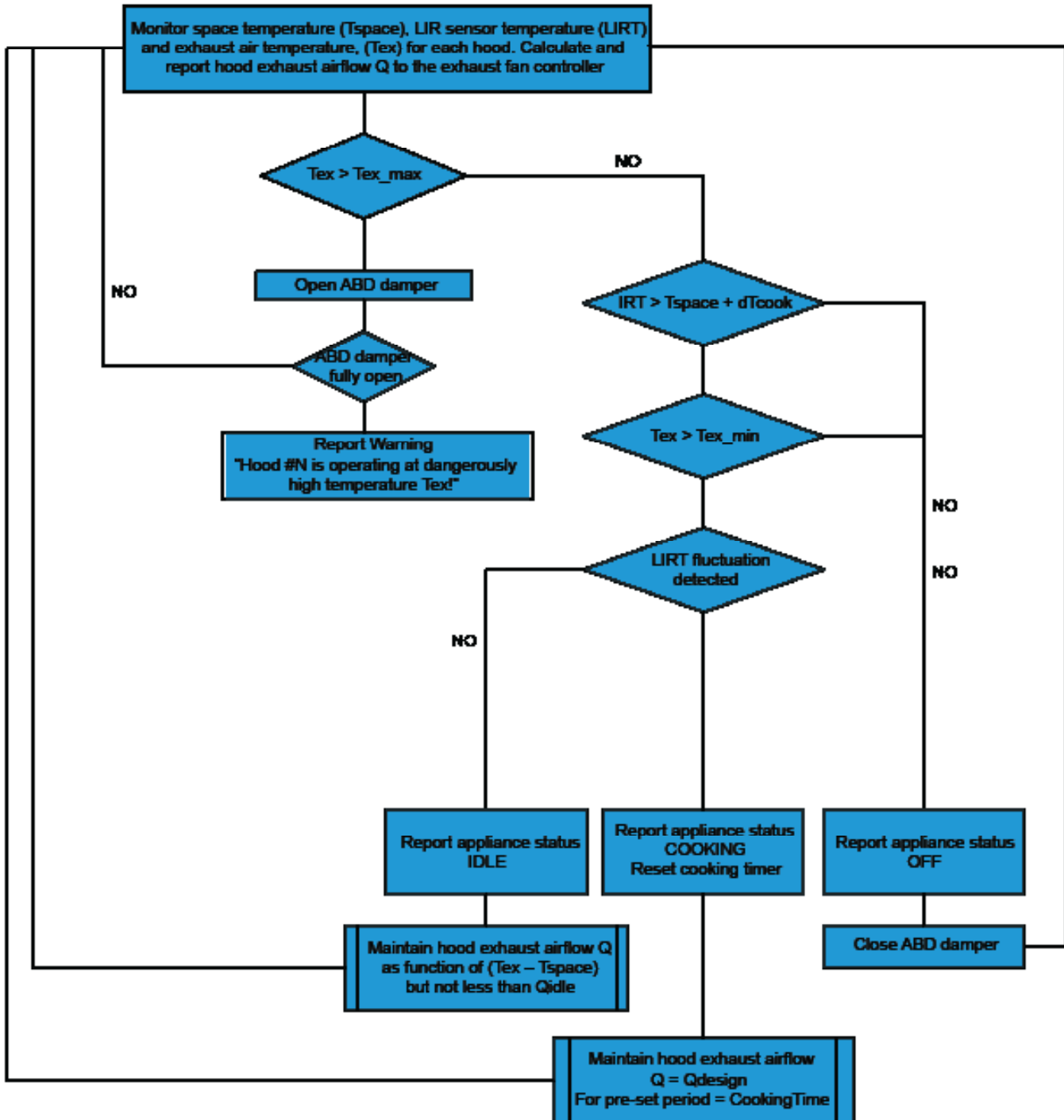

M.A.R.V.E.L. System Installation

The following installation steps ONLY apply to the M.A.R.V.E.L. components (Thermal Imaging Sensor, Distech Control Panel, Pressure Transducer and Temperature Sensor).

Refer to the Capture Jet™ Hood IO&M Manual for complete details on installation of the hoods.

Refer to the Halton engineering drawings for additional details.

Refer to the Halton wiring drawings for configuration details.

Refer to the fan manufacturer's manual for detailed instructions on the fan installation.

It is the responsibility of the installing contractor to see that the system installation is completed in accordance with the project plans and specifications and that it meets all specific requirements of local code officials. The local authority having jurisdiction could over rule some of the installation details written in this manual.

The installation shall be in accordance with NFPA-96. All electrical systems shall be installed following local and national codes.

If questions or complications should arise during the installation of the Halton hood(s) that cannot be solved using the instructions provided, please contact the Halton office at 1-800-442-5866, or (1-800-4-HALTON).

If a problem cannot be correct through verbal or written communication with Halton support, the system can be connected to the Internet for remote access to Halton engineers through the KONTAR-Konsole™ Commissioning and Diagnostic Software Interface.

If the site doesn't have reasonable access to the Internet, a wireless CDMA router can be shipped by Halton to the facility for temporary (or permanent) access.

Check all local codes prior to installation as special requirements may be necessary depending on local building material construction.

1. Mount the central control panel (for multiple units with a single fan)

NOTE: For all units, there is a pre-mounted control panel behind a cover on the Capture Jet™ plenum

1. The central control panel is supplied with mounting tabs that extend from the back wall up and down and provide at least four points of attachment. The appropriate mounting hardware is to be used depending on the unit size and the type of wall to be attached to.
2. Locate the central control panel at an appropriate mounting height (e.g., access to the control in the front door of the panel).
3. Attach the central control panel using the four mounting holes:
 - For concrete block walls, solid block and brick surfaces: Use sleeve stud anchors (recommended).
Example: 3/8 " dia.- thread: 5/16-18; washer OD: 7/8 "(Drill size 3/8 ")
 - For Plaster, Wallboard and Plywood: Use sleeve screw anchors (drive or drill style) (recommended).

Example: 1/4" - 20 drill size 7/16"



NOTE: If more than one control panel is used in a M.A.R.V.E.L. system with a single exhaust fan, connect them together to ensure that proper operation of the exhaust fan. Refer to the Halton supplied wiring diagram for details.

2. Make central control panel connections (for multiple units with a single fan)

Make the following connections at the central control panel:

- a. 120 VAC, 5 amp power to control panel.
- b. Space temperature sensor to control panel (2 wires).
- c. VFD terminal block to control panel (8 wires shielded).
- d. Connection to individual hood (2 wires shielded) (cable provided by Halton).
- e. Connection to kitchen fire system (2 wires).
- f. Permanent Ethernet connection (if specified).
- g. UV or Water Wash control.

3. Connect VFD controller

Connect VFD controller as per instructions provided. This includes:

- a. Main power connection for the fan motor.
- b. Connection to central control panel.

4. Connect hood control panel to central control panel (for multiple units with a single fan)

Using 2 wire shielded cable provided by Halton, connect each unit to the central control panel. This includes:

1. Attach the wire to the terminal block in the box on top of the hood.
2. Run the wire to the central control panel and connect the marked terminal block (identified by hood number).
3. Connections can be also made between hoods with 2 wire shielded cable and connect the hood closest to the control panel to terminals in the panel.

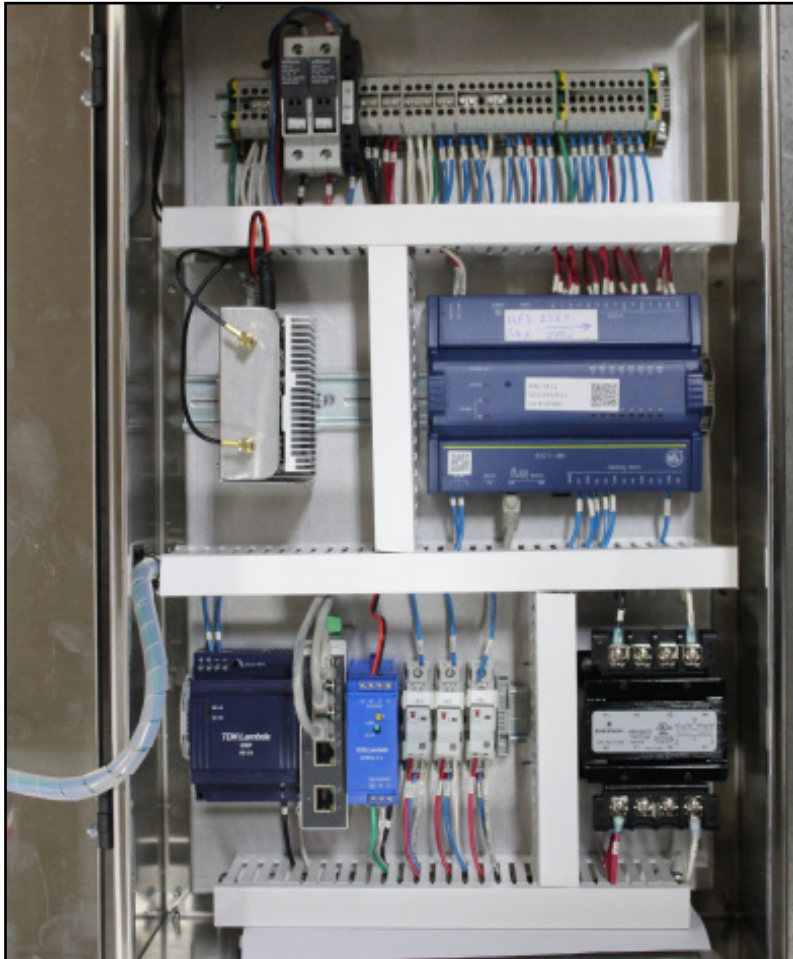

5. Check pressure transducer

1. Check the condition of the pressure transducer tubing on the top of the Capture Jet™ hood. The tubing should be free from kinks.

6. Calibrate the Capture Jet™ plenum and the exhaust air flows.

There are Test and Balance ports on the Capture Jet plenum on the inside front of the hood and on the exhaust plenum at the back of the hood. Measured static pressure at these locations directly corresponds to the airflow through these plenums. The Capture Jet pressure is set at the factory and should need no adjustment. Check the pressure at the Capture Jet plenum T.A.B. port to ensure it corresponds to the positive static pressure in the chart below (plus or minus 0.02" or so). Place the tube from the positive port of the manometer on the T.A.B. port and leave the negative port open to atmosphere.

The exhaust plenum static pressure, measured at the exhaust plenum T.A.B. port, directly corresponds to the total exhaust airflow in cfm through the hood. This is measured in negative inches of water column. Place the tube from the negative port of the manometer on the exhaust plenum T.A.B. port and leave the positive port open to atmosphere. The exhaust plenum T.A.B. pressure that corresponds to the design exhaust airflow in cfm is found on the job specific submittal drawings and this number should be consulted. The M.A.R.V.E.L. DCV system is self balancing and no adjustment should be required.

Check the Capture Jet™ plenum and exhaust plenum air flows using the T.A.B.™ (Testing and Balancing Ports).

To determine the correct T.A.B. port reading for the exhaust hoods, follow these steps:

1. Ensure that the equipment is operating to create a thermal plume prior to the air balancer.
2. Confirm the correct Capture Jet T.A.B. port reading (IWC) based on the Capture Jet™ hood model.

Capture Jet Plenum Hood Model	T.A.B. Port Readings Design T.A.B. (inches WC)
KVE/KVC	0.25
KVW	0.25
KVR	0.25
KVL	0.28

"Example Only"

3. Using the exhaust plenum T.A.B. Port, take a reading in negative inches of water column (IWC)
4. The table below shows the relationship. Confirm the design exhaust airflow (e.g., 1700 cfm), based on the exhaust plenum T.A.B. Reading (e.g., 0.19 IWC). Submittal drawings show correct T.A.B.

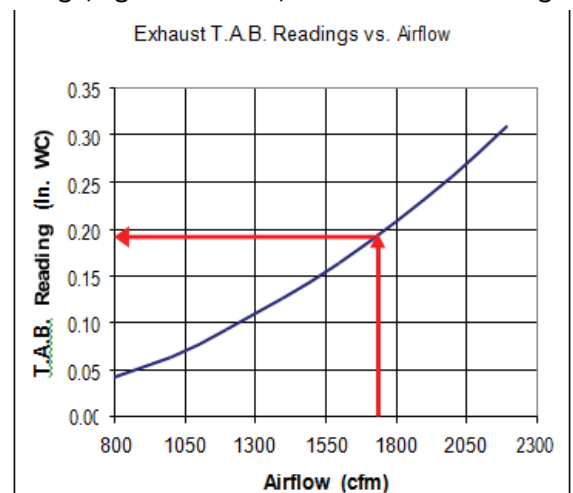
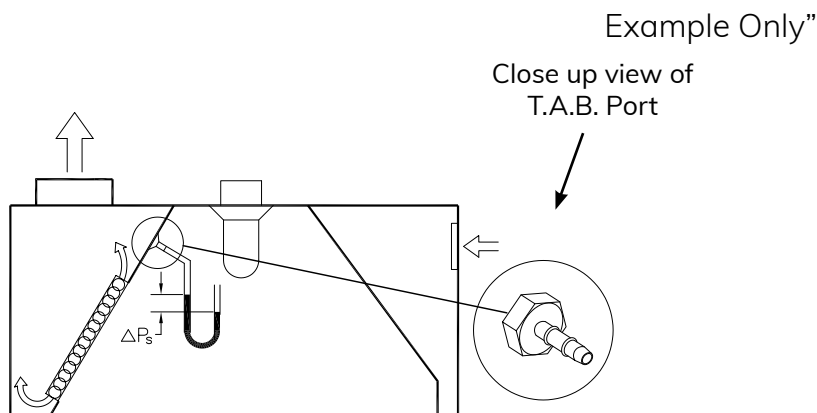

Halton FireWatch

General Description

Halton FireWatch is a 24/7 electronic fire warning system with data backup. FireWatch monitors the heat signatures of cooking surfaces and the kitchen hood's plenum air temperatures.

Halton FireWatch does not replace the hood's fire suppression system.

An anomaly is detected when conditions are favorable for a fire at the appliance and the hood. A 2 stage notification is initiated:

Stage 1 – Visual warning is initiated - Flashing HCL light in hood, or strobe light, and text warning on touch screen. Intervention by the kitchen staff should take place immediately to lower temperatures at appliances to prevent a potential fire. If action is not taken, system may proceed to Stage 2 - AN APPLIANCE FIRE IS HIGHLY LIKELY AT THIS POINT!

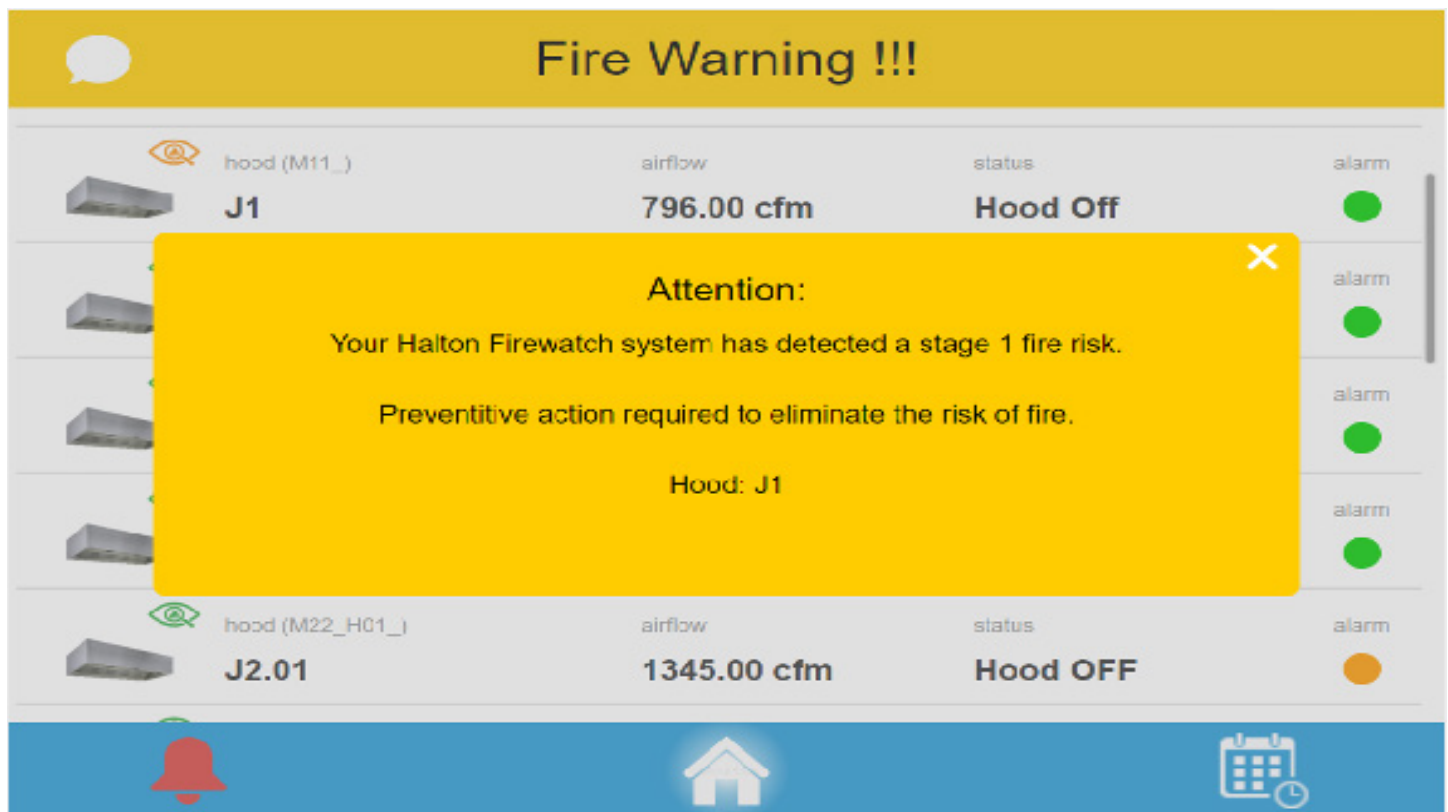

Stage 2 – Visual warnings and audible warnings are initiated - Flashing HCL light in hood, or strobe light, text warning on touch screen and also buzzer at touch screen if the situation has not been addressed. Intervention should take place by the kitchen staff at this point to prevent a fully involved appliance fire and fire suppression system discharge. Equipment should be manually turned off or, if equipped with the optional FireWatch Equipment Shut Down feature, the system will automatically shut off all equipment.



A quick reset of appliances may be accomplished once the dangerous conditions are cleared. Reset Shunt trip in appliance electrical panel and/or Electric Reset Relay for appliance electric gas valves.



FireWatch Components

HCL light with Red LEDs

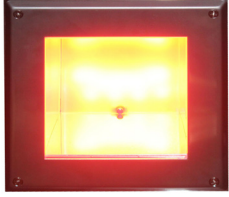

When a Halton hood is equipped with Halton Culinary Lights (HCL), one of the lights will turn from white to red as an alarm signal. A steady red light indicates the FireWatch control panel has lost power, and the system is not functional. A flashing red light indicates the system has gone into Stage 1 alarm.

Thermal Imaging Sensor



This is a Thermal imaging Sensor. This sensor monitors the appliance temperature and notifies the control algorithm if the appliance approaches a temperature where a fire is likely. This sensor is located in the roof of the hood, in the light panel, aimed at the appliance.

RTD Temp Sensor



If the FireWatch equipped hood does not have Thermal Imaging Sensors, an RTD temperature sensor is used to monitor the appliance temperature and notifies the control algorithm if the appliance approaches a temperature where a fire is likely. This sensor is located in the roof of the hood, in the light panel.

- Halton FireWatch does not replace a fire suppression system.
- It will warn an operator before the hood's fire suppression system is discharged and if fire is not extinguished after discharge.
- FireWatch will have a valuable record stored on a Cloud about how and where fire started and why it wasn't suppressed.
- This data will be used to further improve system analytics and prevent similar accidents in the future.

The Halton FireWatch system consists of a series of thermal imaging and temperature sensors to monitor cooking activity for abnormalities that are a precursor to a fire event. The goal of the system is to alert the user to conditions that increase the likelihood of a fire and prompt you to take action.

When a FireWatch alarm is triggered, the system's touchscreen informs the user of what is happening and necessary actions to take to avoid shutdown of equipment or reset if necessary. User can manually restore power on site. Instructions with explanation why power is disconnected and how to restore power are shown on the FireWatch system's touch screen and communicated via email or text to the person of record on site. Both power disconnection and manual power restore events are recorded locally at the controller level and on the cloud. Power is restored automatically when alarm conditions are no longer valid.

Normal Operation - Status OK - HMI Screen shows:

The screenshot shows the Halton FireWatch HMI interface. At the top, there is a blue header with a gear icon on the left and the 'Halton' logo in the center. Below the header, the interface displays the location 'Kitchen' with a fire watch icon and a magnifying glass icon. The main area shows a table of fire factors with their names, values, and status indicators.

name	value	status
H01 fire factor	Normal	●
H02 fire factor	Normal	●
H03 fire factor	Normal	●
H04 fire factor	Normal	●
name	value	status

At the bottom, there is a blue footer with three icons: a bell (notifications), a house (home), and a calendar (schedule).

Stage 1 - Visual warning is initiated - **HMI Screen shows:**

- Flashing HCL light at hood and text warning at HMI touchscreen

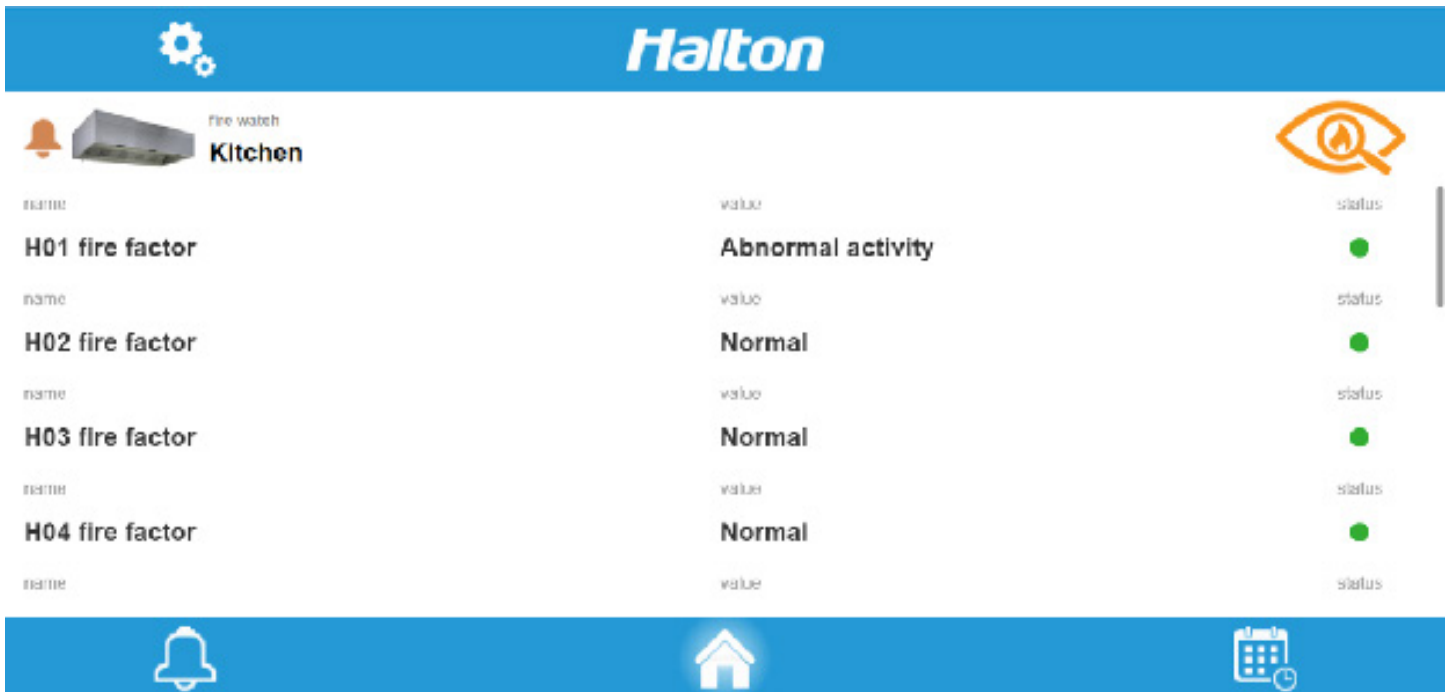

Stage 2 - if the warning is not acted upon, Visual and audible warnings are initiated - **HMI Screen shows:**

- Flashing HCL light or strobe light at hood
- Text warning at HMI touch screen
- Buzzer at touch screen
- Halton FireWatch equipment shut down feature is initiated*

*Operator approval required

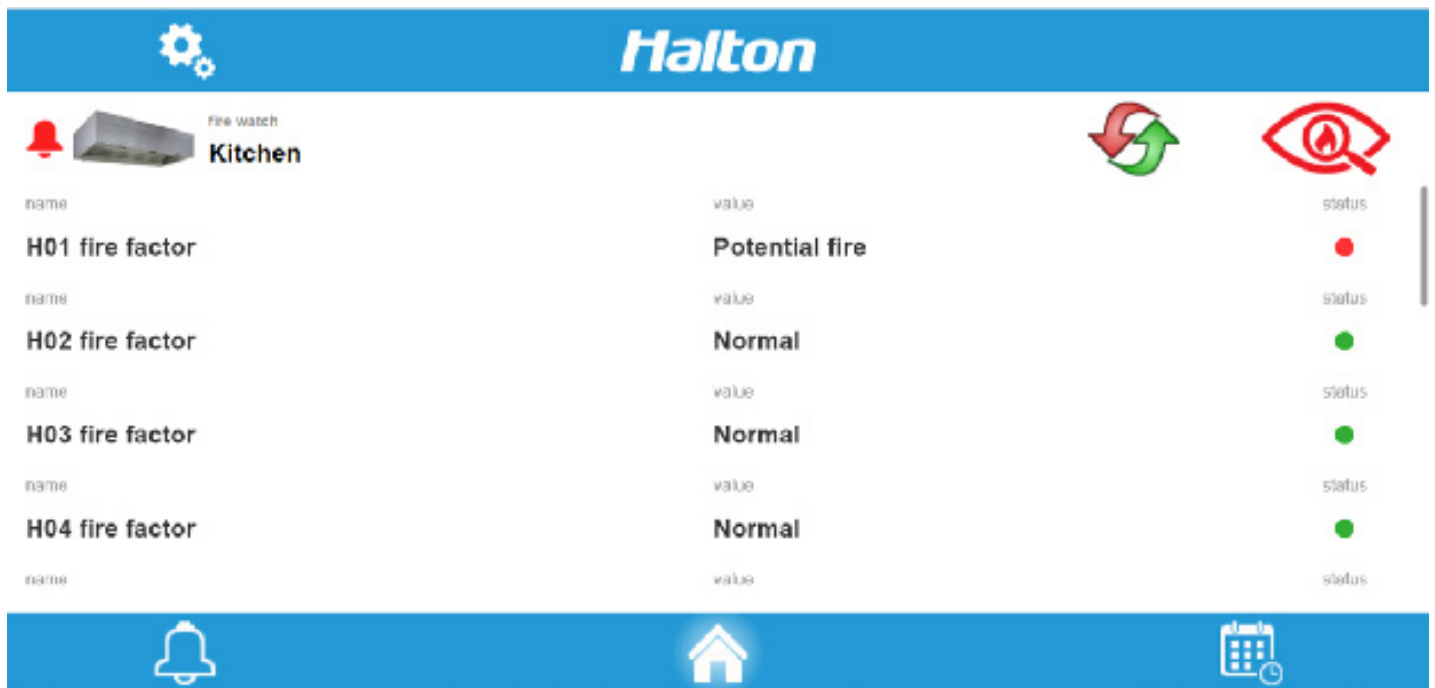

Electronic valves with reset relays are required for natural gas appliance applications. If the optional Appliance Shut Down feature is desired, electrical appliances can be configured with shunt trip breakers or relays and contactors to disconnect power to the electrical appliance.

This is complementary to the hood's fire suppression system; it does not take place of it nor eliminate it from acting in a normal fashion (including a power failure event).

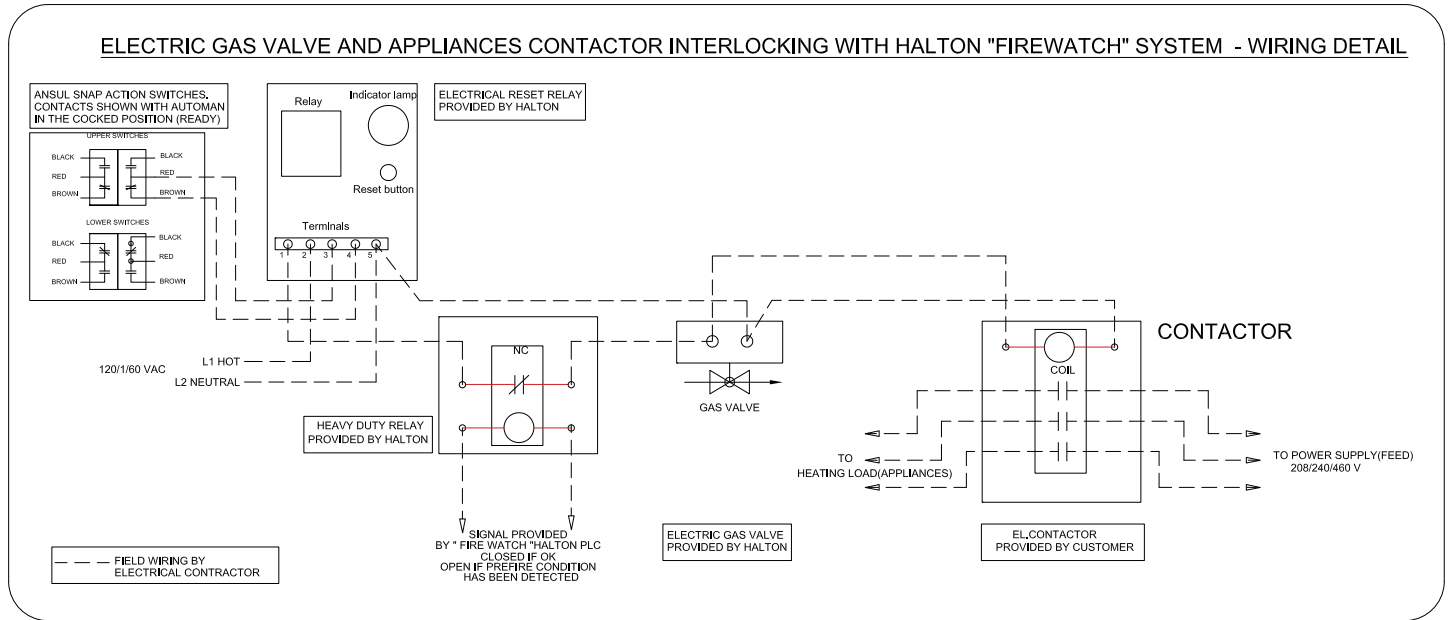

LIFE-SAFETY ISSUE!! Do not bypass or alter any components of this system

Wiring of the HCL lights with central HCL light with Red Alarm function

Typical Wiring of Capture-Jet Fan W/HALTON SUPPLIED SWITCH PANEL

— BY HALTON
 — BY ELECTRICIAN

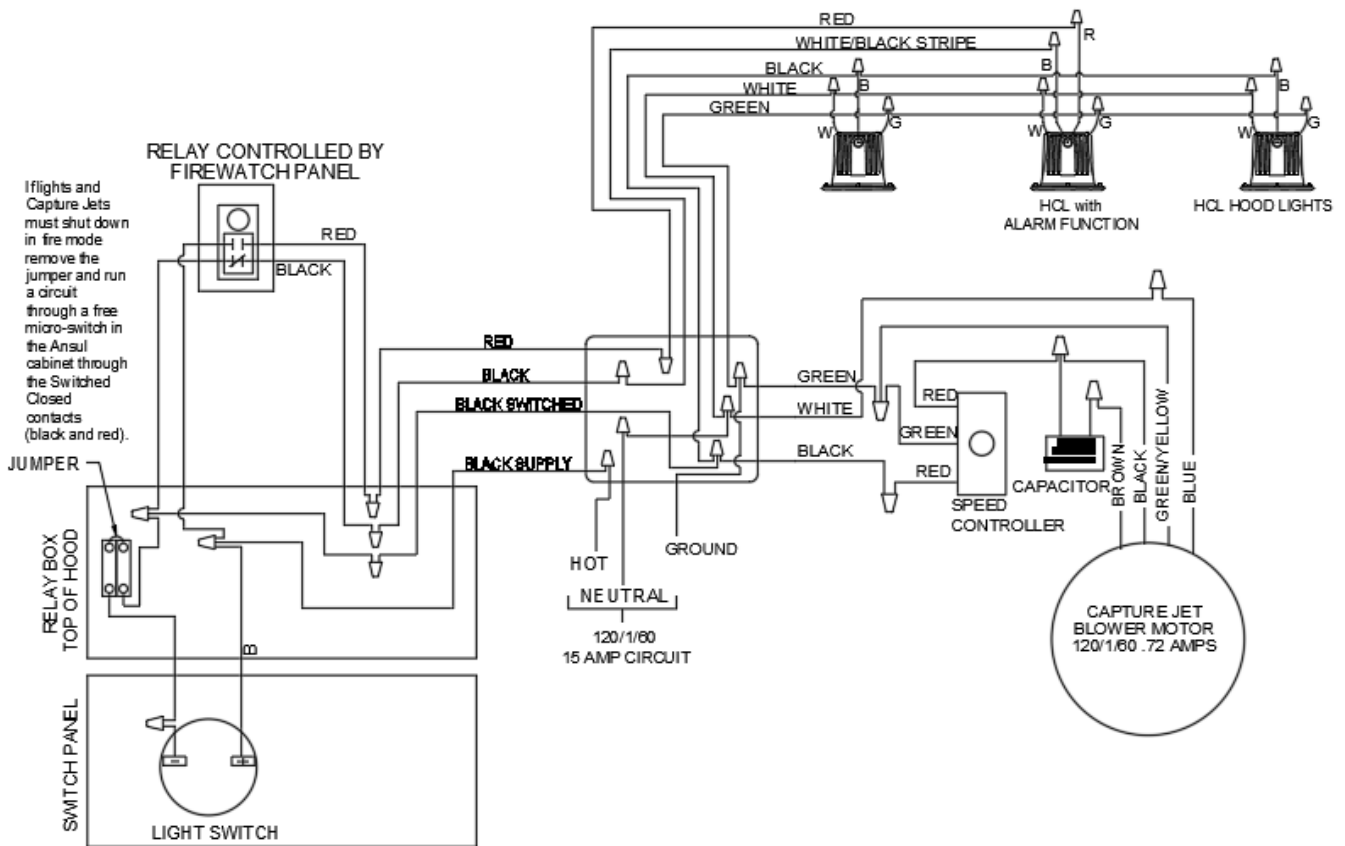

M.A.R.V.E.L. System Maintenance

General

NOTE: A preventive maintenance program is an important aspect of an effective safety program. Consult your manufacturing or other qualified consultant with question concerning changes observed during periodic inspections and routine maintenance.

Refer to the Capture Jet™ Hood IO&M Manual for complete details on maintaining the hoods.

The following maintenance steps ONLY apply to the M.A.R.V.E.L. components (Thermal Imaging Sensor and Temperature Sensor).

Thermal Imaging Sensor Cleaning

NOTE: The Thermal Imaging Sensor is mounted on the Capture Jet™ plenum door to allow an air jet to protect the sensor optics from contaminants. However, periodic cleaning may be required to keep the optics clear.

Gently clean the Thermal Imaging Sensor socket with isopropyl alcohol on a cotton swab (Q-tip™), as required.



Temperature Sensor Removal/Replacement

To remove the temperature sensor located in the hood collar, follow these steps:

1. Disconnect the temperature sensor from the terminal block located in the Capture Jet™ hood. Refer to the terminal block diagram on the Halton-supplied wiring diagram for the correct terminations points.
2. Loosen the compression fitting securing the temperature sensor in the hood collar.

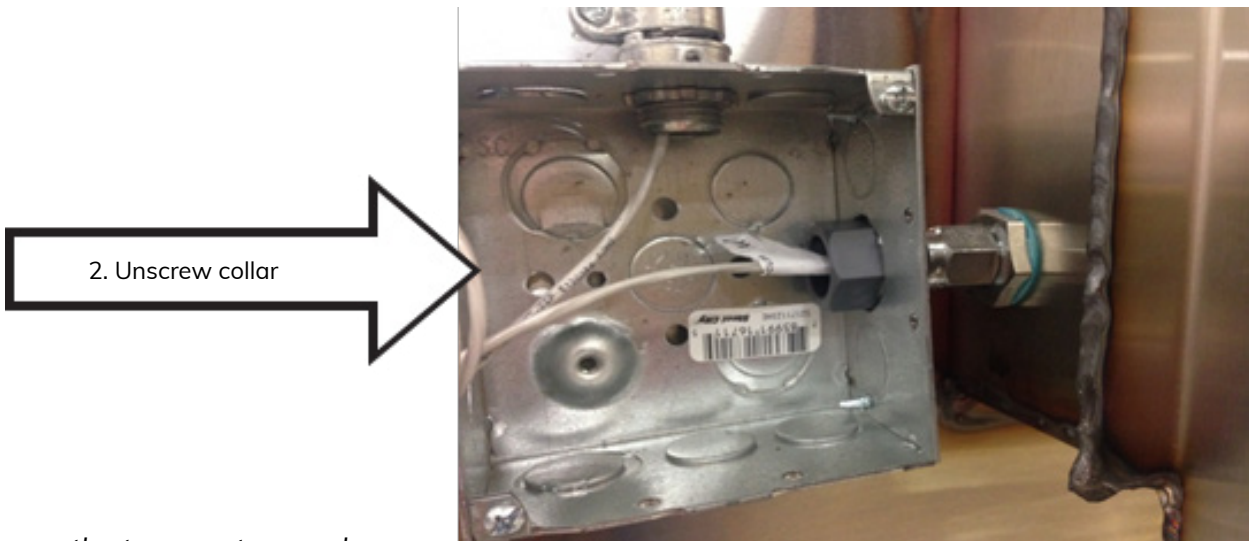

3. Remove the temperature probe.
4. Replace the defective temperature probe with a replacement (Halton Part # 17641)
5. Reconnect wiring.

Balancing Damper Actuator Removal/Replacement

Halton ABD Dampers use two different actuators to move the damper blades, depending on the size of the damper. The Neptronic model BM060(HA1) is used on the smaller ABD dampers, sizes 8" x 8" to 9" x 10". The Belimo model MFX24-MFT is used on the larger ABD dampers, sizes 10" x 10" to 30" x 36".

To remove and replace the Neptronic actuator on the balancing damper, follow these steps:

1. Remove exterior metal cover by removing the 6 mounting screws around the perimeter.
2. Remove the actuator cover by removing the 1 screw on the side.
3. Disconnect the power to the actuator.
4. Record the DIP switch values, located in the red holder on the bottom of the actuator.

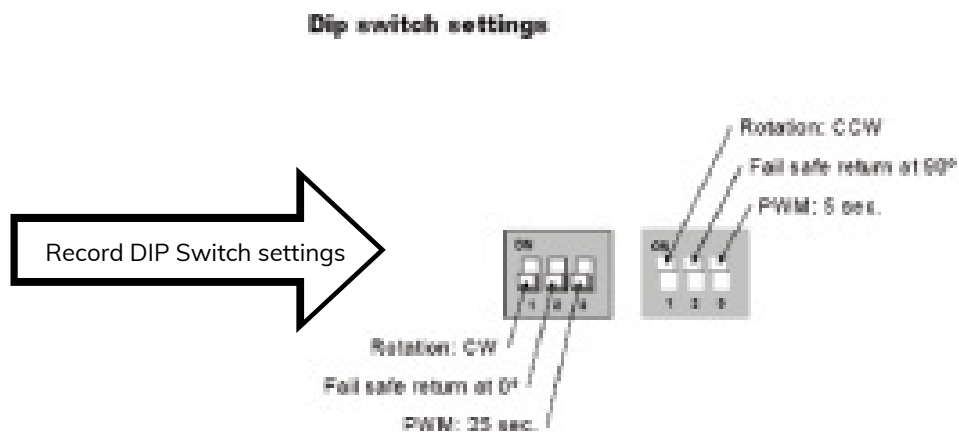

5. Note the position of the stop screws.

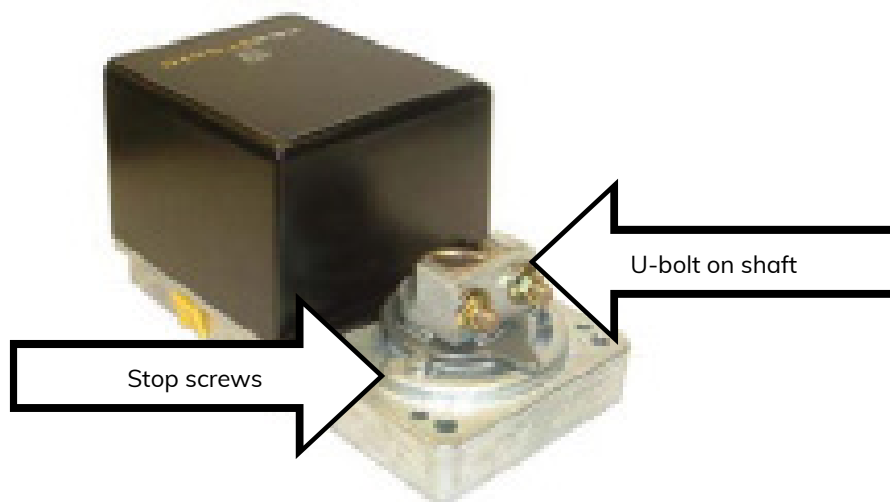

Remove the U-bolt that attaches the actuator to the balancing damper shaft. Refer to the Actuator Specification and Installation instructions with the replacement part.

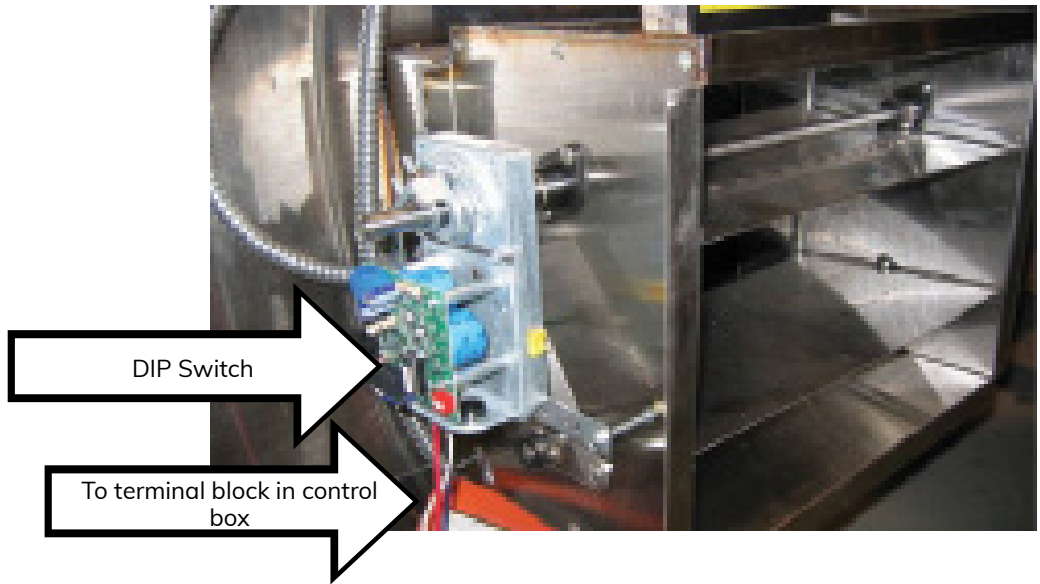

Replace with a replacement actuator (Halton Part # 10842). Tighten the U-bolt on the drive shaft.

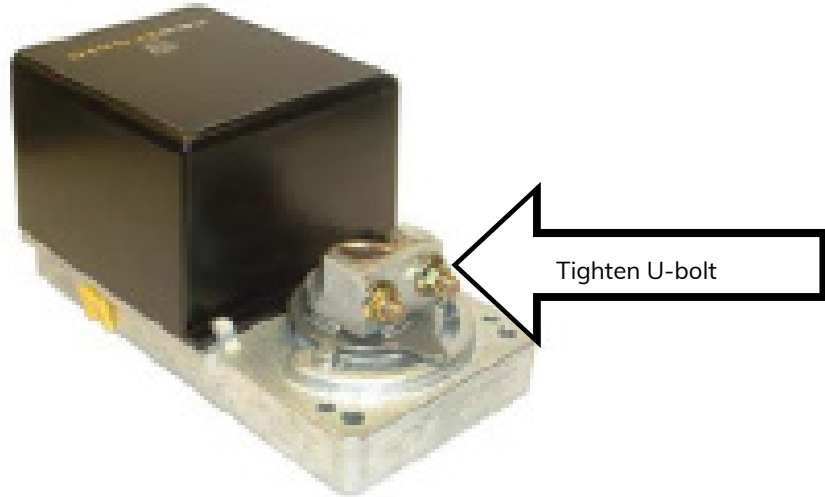

6. Reset the DIP switches.
7. Reset the stop screws.
8. Reconnect the power.
9. Calibrate the new actuator by pressing the Reset button. The dampers will open and close.
10. Replace the actuator housing and the exterior metal cover as before.

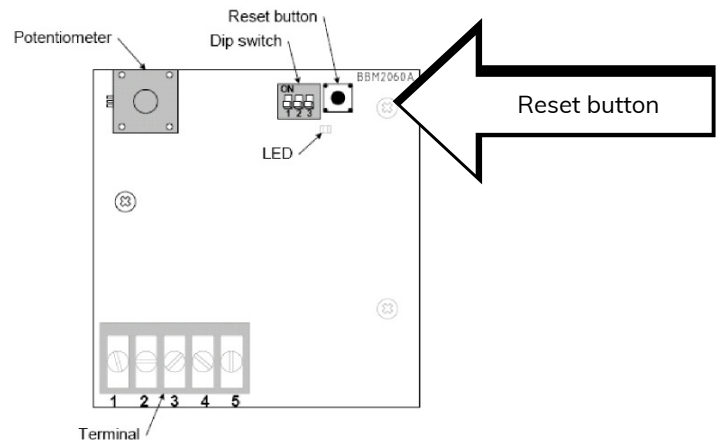

Balancing Damper Actuator Removal/Replacement - Belimo

Halton ABD Dampers use two different actuators to move the damper blades, depending on the size of the damper. The Neptronic model BM060(HA1) is used on the smaller ABD dampers, sizes 8" x 8" to 9" x 10". The Belimo model MFX24-MFT is used on the larger ABD dampers, sizes 10" x 10" to 30" x 36".

To remove and replace the Neptronic actuator on the balancing damper, follow these steps:

The Halton USA part number is 10842 and the Halton Canada part number is 16012.

Add the following text and pictures after the Removal/Replacement instructions for the Neptronic actuator beginning on page 8 of OM017 and page 31 of OM070:

To remove and replace the Belimo actuator on the balancing damper, follow these steps:

Remove exterior metal cover by removing the 6 screws around the perimeter of the cover.

Disconnect the power to the actuator.

The Belimo damper has a wire pigtail attached to it. It wires directly into the hood's onboard PLC except in cases, like dual exhaust collars, when the damper might be too far away from the PLC for the length of the pigtail. In that case a j-box is added to the top of the hood and jumper wires will extend the pigtail from the j-box to the PLC. (The wire colors for the jumpers will not necessarily be consistent. Please take careful note of what color jumper wires are connected to what color pigtail wires before disconnecting the wires in the j-box.)

Remove the U-bolt (shackle in below picture) that attaches the actuator to the balancing damper shaft. Remove the actuator. Refer to the Actuator Specification and Installation instructions with the replacement part.

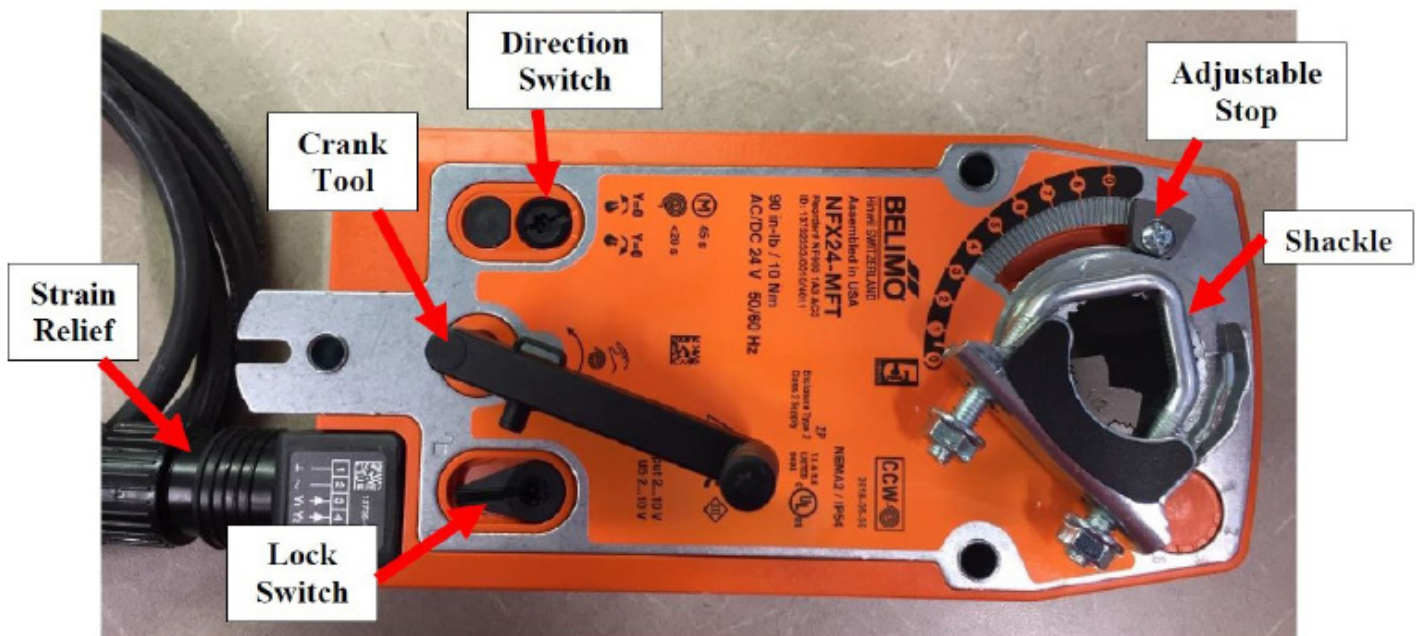



Replace with a replacement Belimo actuator (Halton Part # 10843). Tighten the U-bolt on the drive shaft.

Ensure actuator is attached to damper body. Remove included strain relief from actuator body. Remove the strain relief by pulling the collar of the strain relief away from the actuator and pressing down on the end away from the actuator with a breaking motion. Teeth on the strain relief will pop out of a groove on the rubber casing on the cord. Remove the strain relief from the cord and discard.



Make sure flat of the axle rod is against the flat of the shackle to prevent shifting.



Using the provided crank tool, close the actuator until the blade tips touch at the top and lock the actuator in this position with the Lock Switch.



Adjust the stop to this location and tighten screw.

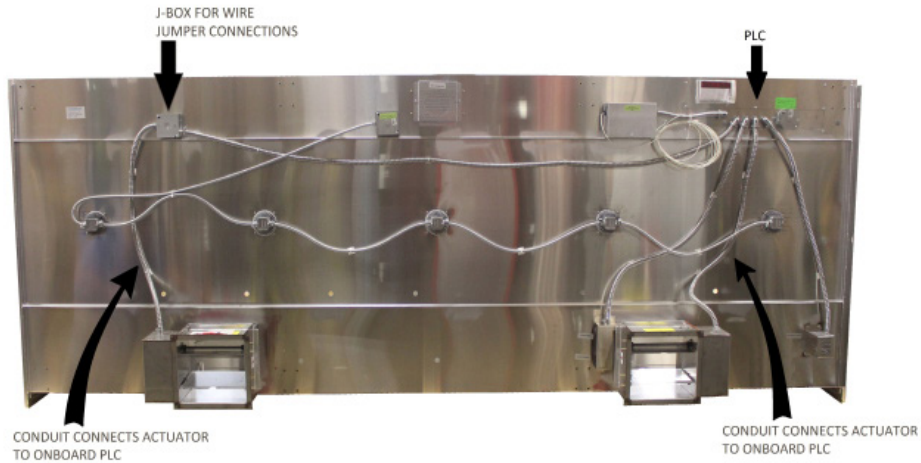

Release actuator lock switch. Actuator spring will return damper to the open position. Ensure the blades are in the correct vertical open position.

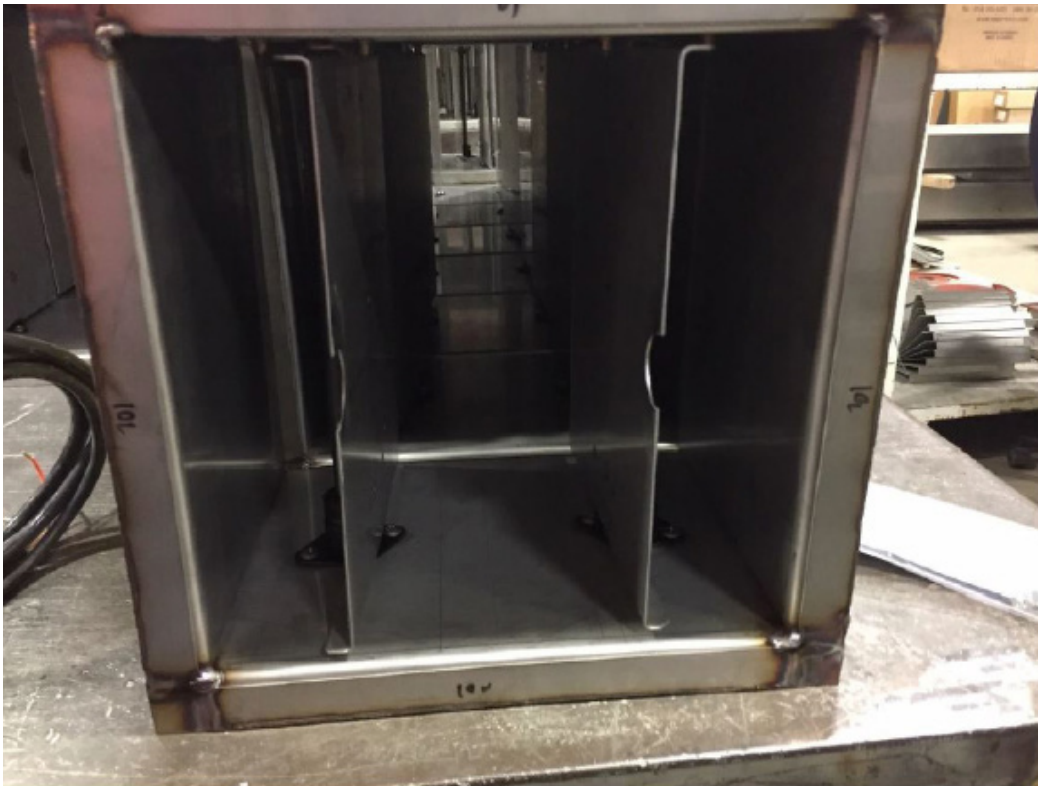

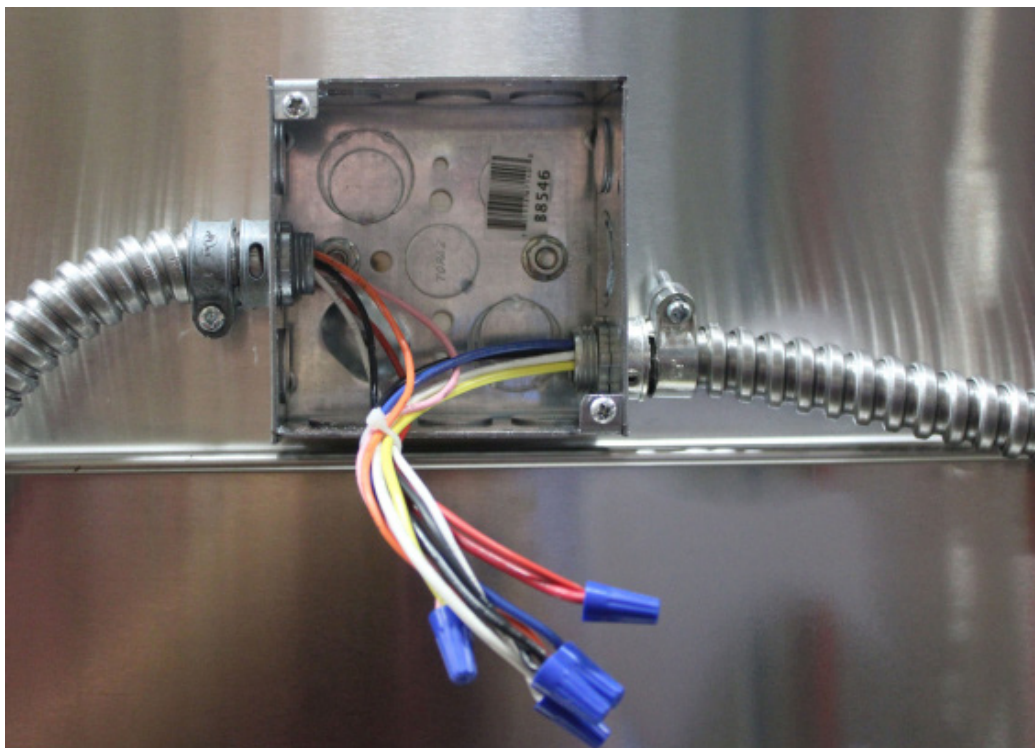

J-box opened to show jumper wires connections.

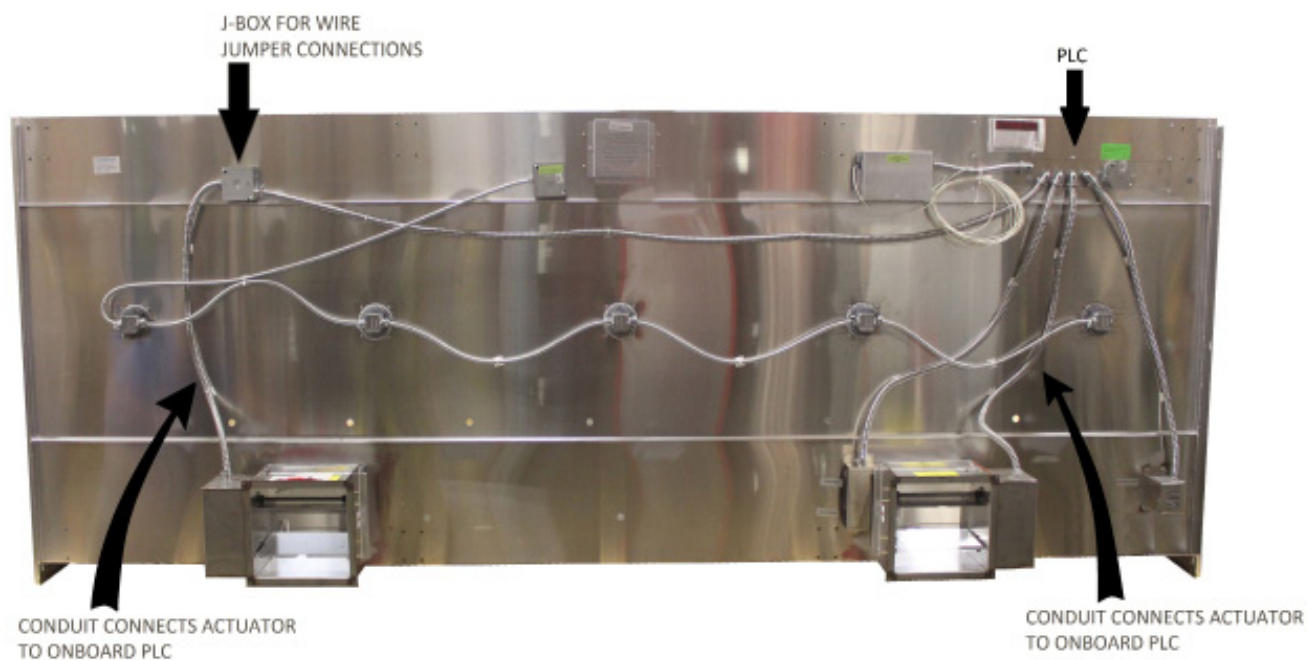

Thread the actuator wiring pigtail through the grommet in the cover and route the wire through the conduit to the PLC enclosure or the J-box where the disconnections were made. Reconnect the power.

Replace the exterior metal actuator cover as it was before.

Pressure Transducer Removal/Replacement

To remove the pressure transducer, follow these steps:

1. Turn off power to transducer.
2. Remove covering on pressure transducer mounting bracket.
3. Disconnect wires.
4. Disconnect ¼" tubing fitting from LOW port on transducer.
5. Remove side mount screws (2 screws).
6. Replace with Halton Part # 18028).
7. Reconnect wires and tubing as before. Check that the tubing is not kinked.



M.A.R.V.E.L. System Monitoring and Support

Types of Monitoring

Ethernet connection



USB Cable connection

Type of Mounting	Details
Permanent Ethernet-connection for 24/7 monitoring	<ul style="list-style-type: none"> Optional. Permanent internet monitoring using SCADA graphical interface. By using a unique password and ID, user can check system status and, depending on access levels, change parameters and alarms.
Temporary Ethernet connection, as required, for support	<ul style="list-style-type: none"> Temporary Ethernet connection for startup/troubleshooting by Halton Technical Support only
Temporary cable to laptop connection, as required, for support	<ul style="list-style-type: none"> USB cable connection to laptop pre loaded with KONSOLE™ software for diagnostic support.

Connection to Third Party Devices

- Able to communicate natively to Modbus RTU slave devices over RS232 or RS485.
- Able to communicate via BACnet MSTP, BACnet IP, Modbus RTU as a Slave or JCI N2 protocols via optional gateway.

Frequently Asked Questions

Problem	Probable Cause	Solution
Exhaust damper blades do not open or close	Loose set screws	Tighten
	In-operable motor	Replace
No suction at hood	VFD tripped	Check for error code, reset
	Surface and duct temperature sensors not activated	Push override button

M.A.R.V.E.L. Parts List

The following is the recommended parts list for proper care and maintenance of the M.A.R.V.E.L. equipment. Parts indicated with a * should be kept readily on hand, the amount depending on the number of hoods in the system.

NOTE: Contact Halton for information on other replacement parts as required

Part	Halton Part Number
Pressure transducer* (for each hood)	18081
Temperature sensor*	18024
Thermal Imaging Sensor*	12919
Actuator* (for balancing damper) (optional)	16012
Distech Controller (optional)	18035

Contact Information

United States

Halton Company
101 Industrial Drive
Scottsville, Kentucky
42164
www.halton.com

Tel: 270-237-5600
Toll Free: 800-442-5866
Fax: 270-237-5700

Canada

Halton Indoor Climate Systems
1021 Brevik Place
Mississauga, Ontario
L4W 3R7
www.halton.com

Tel: 905-624-0301
Toll Free: 800-565-2981
Fax: 905-624-5547

WARRANTY FORM

This form must be completed and returned to Halton in order for your warranty to be valid.

Job & Location Information:

Job Name: _____

Street Name: _____

City: _____ State: _____ Zip Code: _____

Equipment Start-Up Date: _____ Product Serial Numbers: _____

Contact Information:

Contact Name: _____

Title: _____

Chef, Kitchen Mgr/Facility Mgr/Property Mgr/etc.

Facility Management Company Name (if applicable): _____

Email: _____

Phone Number: _____ Cell Number: _____

Fax completed form to:
Halton Company
Attention: Service Department
Fax: (270) 237-5700

Halton Indoor Climate Systems
Attention: Service Department
Fax: (905) 624-5547

Halton Limited Warranty

Halton ("Manufacturer"). Warrants only to its direct purchasers and to no others, that all products manufactured by the Manufacturer shall be free from defect in materials and workmanship for a period of twelve (12) months from the date of the original installation and start-up or eighteen (18) months from date of shipment, whichever occurs first. All products sold but not manufactured by Manufacturer will be warranted for a period of twelve (12) months from date of shipment.

For products manufactured by the Manufacturer we agree to pay any reasonable labor costs necessary to repair or replace, at Manufacturers option, defective parts or materials for a period of twelve (12) months from date of original installation and start-up or eighteen (18) months from date of shipment, whichever occurs first. All labor costs subject hereto shall be performed during standard work hours at straight-time rates.

For products sold but not manufactured by the Manufacturer we agree to pay any reasonable labor costs necessary to repair or replace, at Manufacturers option, defective parts or materials for a period of (90) days from date of original installation and start-up or (12) months from date of shipment, whichever occurs first. All labor costs subject hereto shall be performed during standard work hours at straight time rates.

All warranty claims that include labor requires pre-approval by Halton. Halton, at its discretion, will authorize field warranty work through its own service network or certified third party. No claims for labor charges will be approved for payment if work commences without prior authorization by Halton.

Purchaser shall pay incurred premium labor charge, including overtime, weekends and holidays. Travel time, service charges, miscellaneous tools, material charges, and labor charges resulting from inaccessibility of equipment will not be paid by Manufacturer.

This LIMITED WARRANTY SHALL APPLY ONLY to products that have been installed and maintained in accordance with the installation and Care Instruction Manuals. Purchaser shall be solely responsible for adhering to the instructions and procedures set forth in the said instruction manuals.

This LIMITED WARRANTY SHALL NOT BE APPLICABLE to any damage or defect resulting from fire, flood, freezing or any Act of God, abuse, misuse, accident, neglect or failure to adhere to all instructions set forth in the installation and Care Instruction Manuals. Furthermore, this limited warranty shall not apply to any product that has been altered, unless such alteration has been approved in writing by a duly authorized representative of the manufacturer. In no event shall the manufacturer be liable for any loss, expense, personal injury or consequential damage, of any kind or character, as may result from a defect in material, and/or workmanship, however caused.

EXCEPT AS IS EXPRESSLY SET FORTH IN THIS LIMITED WARRANTY, MANUFACTURER MAKES NO WARRANTY OF MARKETABILITY FOR FITNESS OR ANY PARTICULAR PURPOSE. NEITHER DOES MANUFACTURER MAKE ANY WARRANTY, EXPRESSED OR IMPLIED, WITH RESPECT TO PRODUCTS SOLD BY MANUFACTURER OR AS TO THE USE THEREOF.

Continuous product improvement is a Halton policy, therefore specifications and design are subject to change without notice.